

SYAT[®]

希娅特

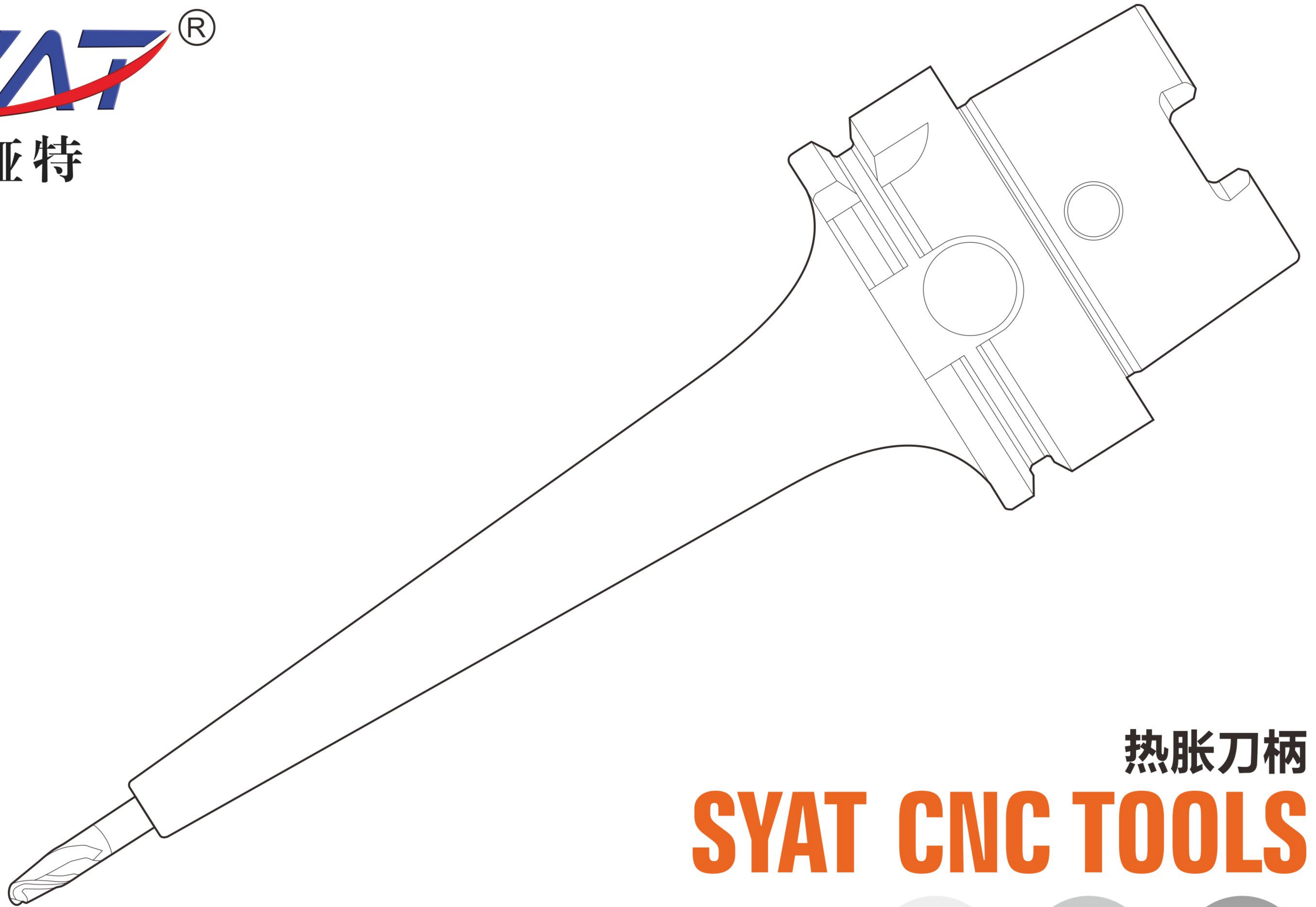

热胀刀柄

SYAT CNC TOOLS

希娅特科技有限公司
SYAT TECHNOLOGY CO.,LTD.

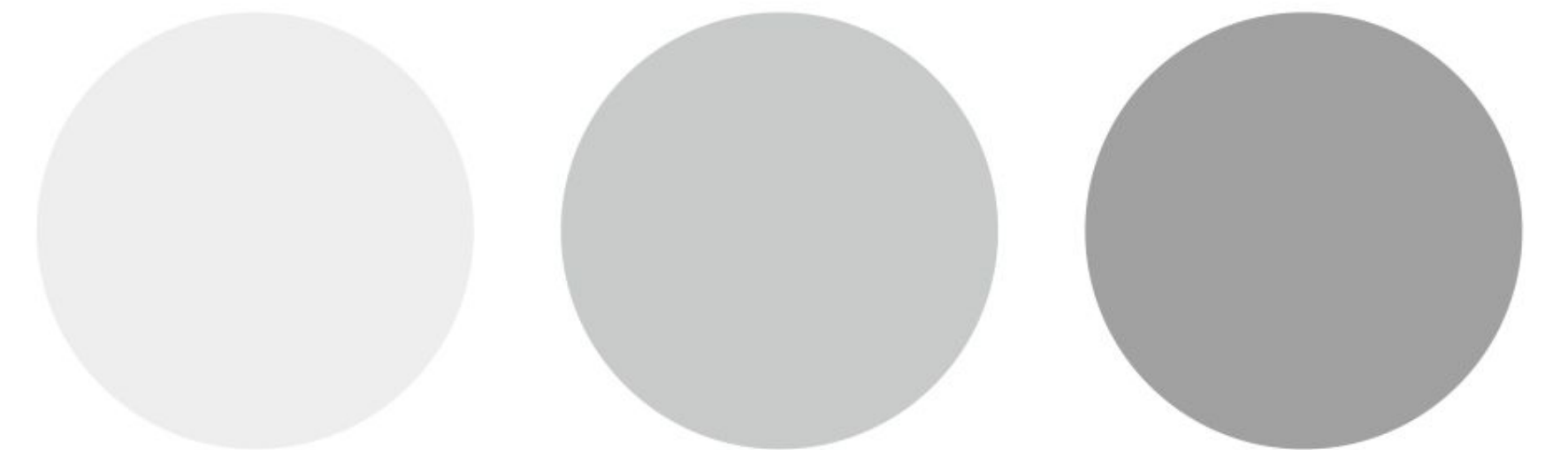



about us 关于我们

希娅特科技有限公司是一家集生产销售服务于一体的企业，公司拥有一支强大的科研开发队伍。主要产品有热胀刀柄系列、电磁感应热缩机、高速刀柄系列、钨钢铣刀系列、数控刀片系列等。

我公司不断推出适合于模具行业、汽车工业、航空工业等先进切削和孔加工等优越刀具，根据客户的不同需求来图来样生产各类其难异形切削刀具，为机械加工制造提供整套的加工方案。

我们本着多元化的产品和优越的性价比进入市场，奉行“科技兴业、质量第一、用户至上、服务至诚”的方针，通过科学的管理和精良的设备，以不断创新的产品和日趋完善的质量满足更多客户的需求。我们期待与新老客户真诚合作，共创美好明天！公司始终坚持“质量第一、客户至上”为企业宗旨，秉持“质量可靠、诚信为本、开拓创新”的经营理念，“真诚、完善、快捷”的营销服务体系，竭诚为满足客户的需求而不懈努力。

SYAT TECHNOLOGY CO.,LTD. is a company integrating production, sales and service. The company has a strong team of scientific research and development. The main products are thermal expansion knife handle series, electromagnetic induction heat shrinkable machine, high-speed knife handle series, tungsten steel milling cutter series, CNC blade series and so on.

Our company has introduced the advanced cutting tools such as mold industry, automobile industry, aviation industry and so on. To sample production of various types of its difficult to special-shaped cutting tools, machining and manufacturing to provide a complete set of processing program.

We in line with the diversification of products and excellent price to enter the market, pursuing a policy of "industrial science and technology, quality first, customer first, sincere service". Through scientific management and excellent equipment, with the continuous innovation of products and improve the quality to meet the needs of more customers. We look forward to the new and old customers sincere

Cooperation, create a better tomorrow! Companies always adhere to the "quality first, customer first" for the purpose of the enterprise, uphold the "quality and reliability, honesty, innovation" Business philosophy, "sincere, perfect, fast" marketing service system, dedicated to meet the needs of customers and make unremitting efforts.

电磁感应热胀仪

输出电源: SINGLE-PHASE 220V 50/60HZ 25AMP 【16AMP (ST-500/450)】

瞬间输出最大功率: 4000W/2500W/1000W (可调) 【3000W/2000W/1000W (可调) ST-500/450】

机体尺寸: 550mm(W),500mm(D),850mm(H)

建议使用范围: ST-550 Φ 3- Φ 32mm/ST-450 Φ 3- Φ 20mm

加热刀杆: 不锈钢材质、合金钢材质

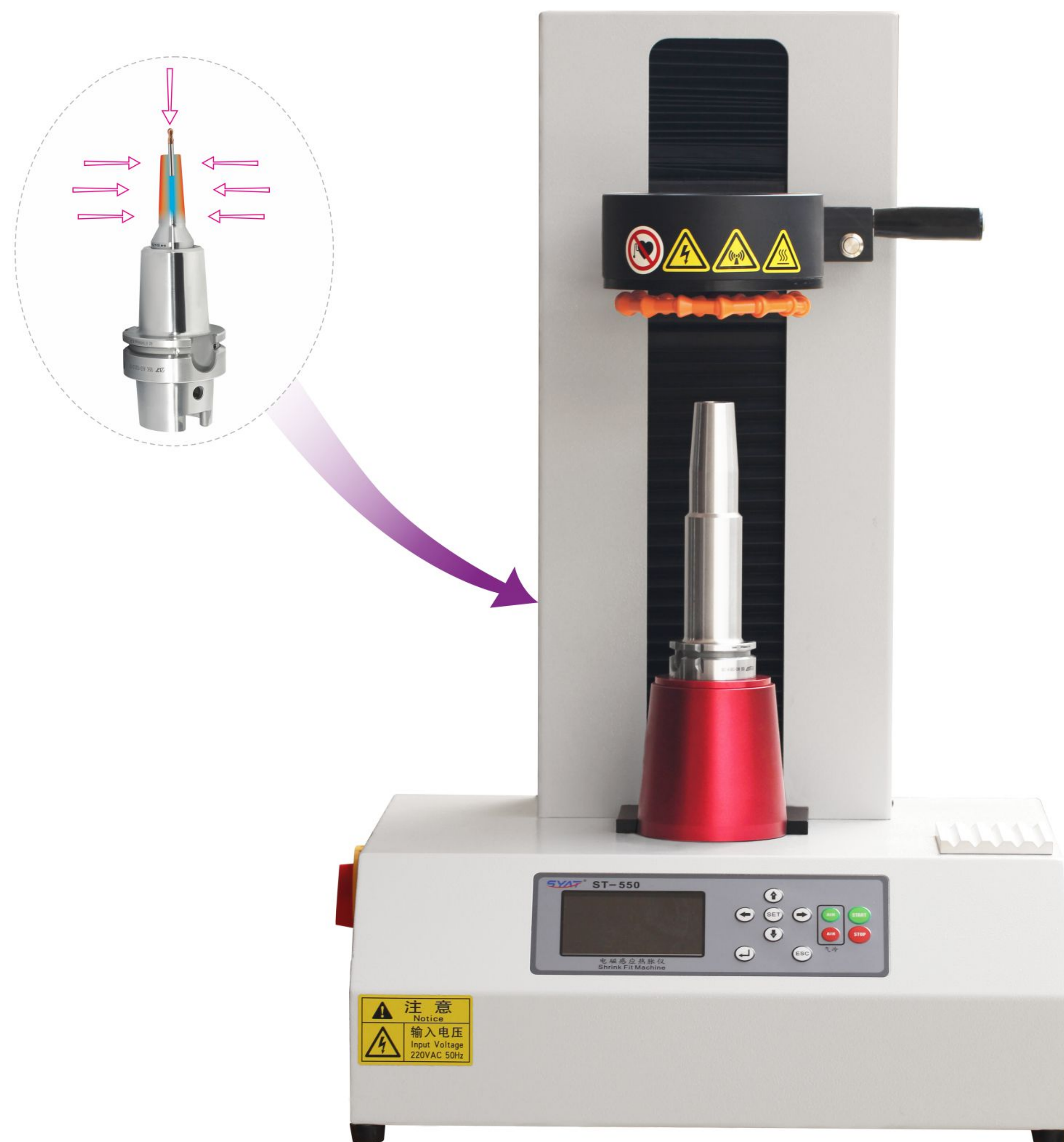

ST-550/500/450 电磁感应热胀仪

ELECTROMAGNETIC INDUCTION THERMAL EXPANSION INSTRUMENT

- 合金钢、不锈钢材质通用
- 加热速度快, 最快仅需5秒 (ST-500加热速度6秒)
- 机器稳定性好
- 无需更换加热导环
- 可直接加热 Φ 3-32mm内径

● 使用安全注意事项

热卸时



禁止反复加热

卸刀时如果一次加热没有成功卸下刀具, 请将刀柄完全冷却后再次加热。

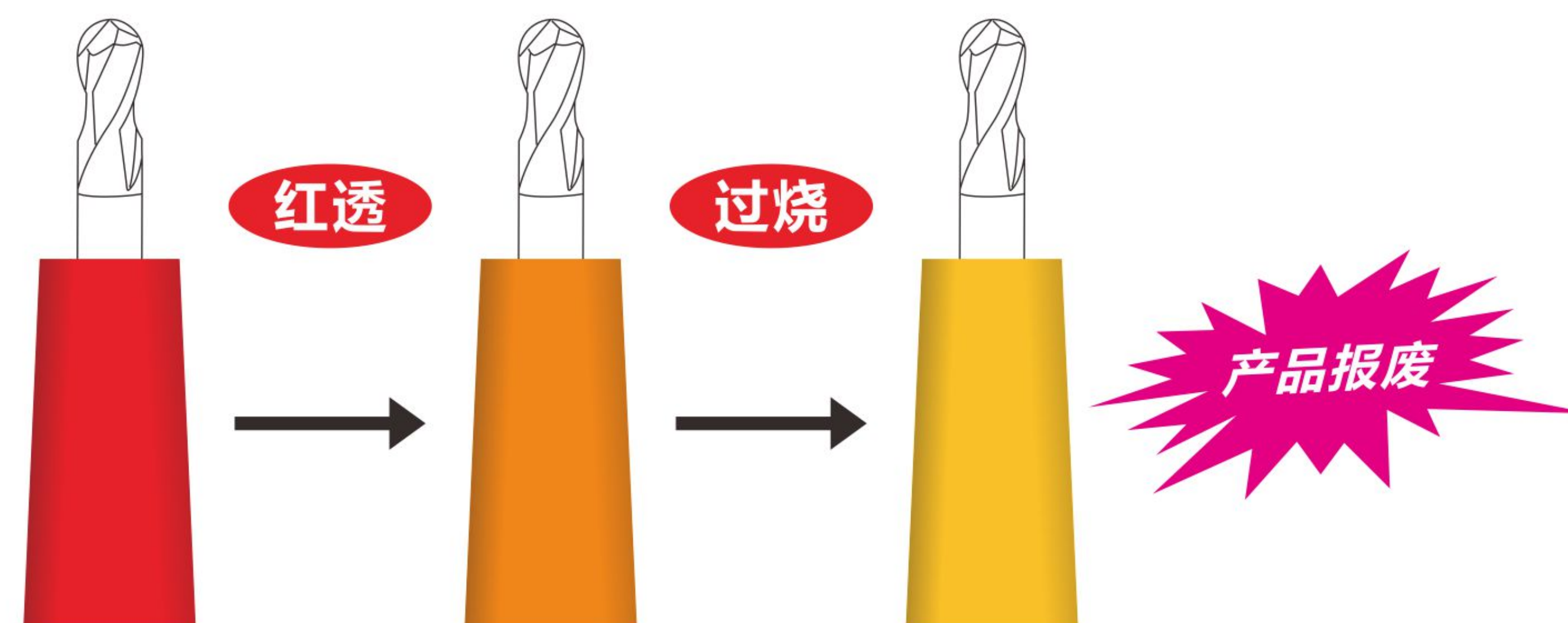

电磁感应热胀仪

ST-550/500/450

电磁感应热胀仪

产品特点

- 加热速度快 (最快5秒)
- 节能环保 (省电)
- 省人工成本
- 1台热胀仪能供5-10台加工中心使用



ST-450



ST-500



ST-550

● 基本参数 Basic Parameters

型号	ST-450	ST-500	ST-550
电源	220V/50Hz (16A) 2.5平方三芯电缆线	220V/50Hz (16A) 2.5平方三芯电缆线	220V/50Hz (25A) 4平方三芯电缆线
功率	3000W/2000W/1000W (可调)	3000W/2000W/1000W (可调)	4000W/2500W/1000W (可调)
气体压力范围	0~0.7Mpa (0~7.0Bar)	0~0.7Mpa (0~7.0Bar)	0~0.7Mpa (0~7.0Bar)
建议使用气管直径	8mm	8mm	8mm
加热材质	不锈钢、合金钢通用	不锈钢、合金钢通用	不锈钢、合金钢通用
加热范围	3~20mm	3~32mm	3~32mm
使用环境温度	-10°~50°	-10°~50°	-10°~50°
外型尺寸	550×500×850mm	550×500×850mm	550×500×850mm
机器重量	40±1Kg	40±1Kg	40±1Kg
保修时间	12个月	12个月	18个月
可选颜色	黑色、白色 (可选)	黑色、白色 (可选)	黑色、白色 (可选)

附件选购

防脱卡簧钳

型号: RSO-125



铣刀防脱卡片

型号: KHS-D



增高底座

型号: ZGDZ-1



刀柄适配器

型号: A63-BT40



后拉适配器

型号: DZ-M10



后拉扳手



保证刀柄清洁及干燥

- 新刀柄使用前，用无尘布擦干净刀柄表面，特别是刀柄内孔要保证清洁及干燥。刀柄在机床上使用后表面有油或者冷却液，使用空气吹干水份，无尘布擦干净表面及内孔，保证刀柄清洁及干燥。
- 请用电磁感应加热装置加热刀柄，装取刀具。
- 若装配的是无内冷孔的拉钉，热拆刀具时请遵循以下操作。
- 热拆刀具进行水冷后，请先将刀柄内部的残留水分倒出，再用气体吹干水分。

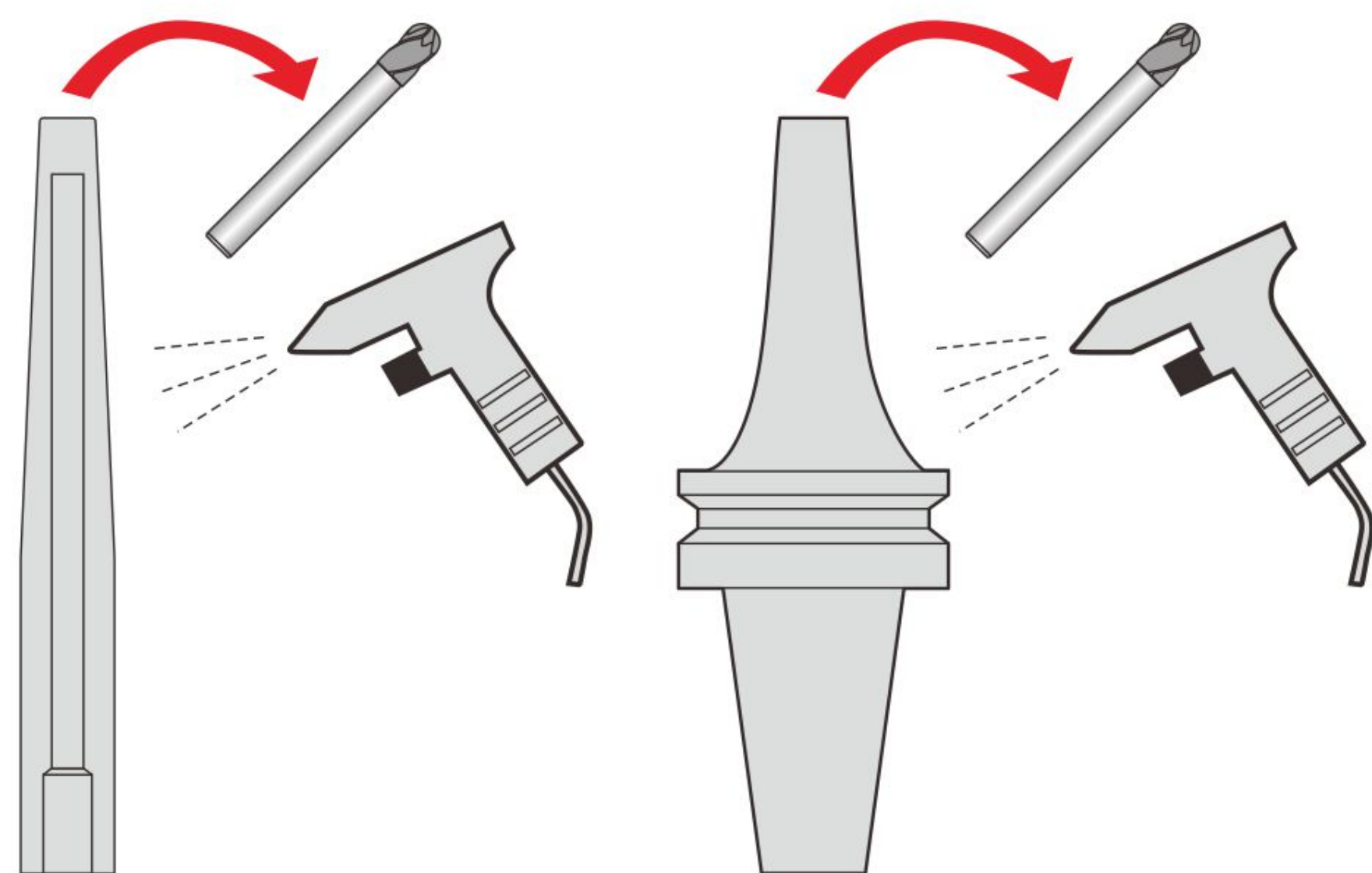

防锈作业

- 热胀刀柄不使用期间，尽量不要取下铣刀，保证刀柄内孔不氧化，请使用防锈油喷刀柄表面，保证刀柄不产生锈迹，使用热装之前请使用无尘布擦干净刀柄表面，保证刀柄清洁干燥。

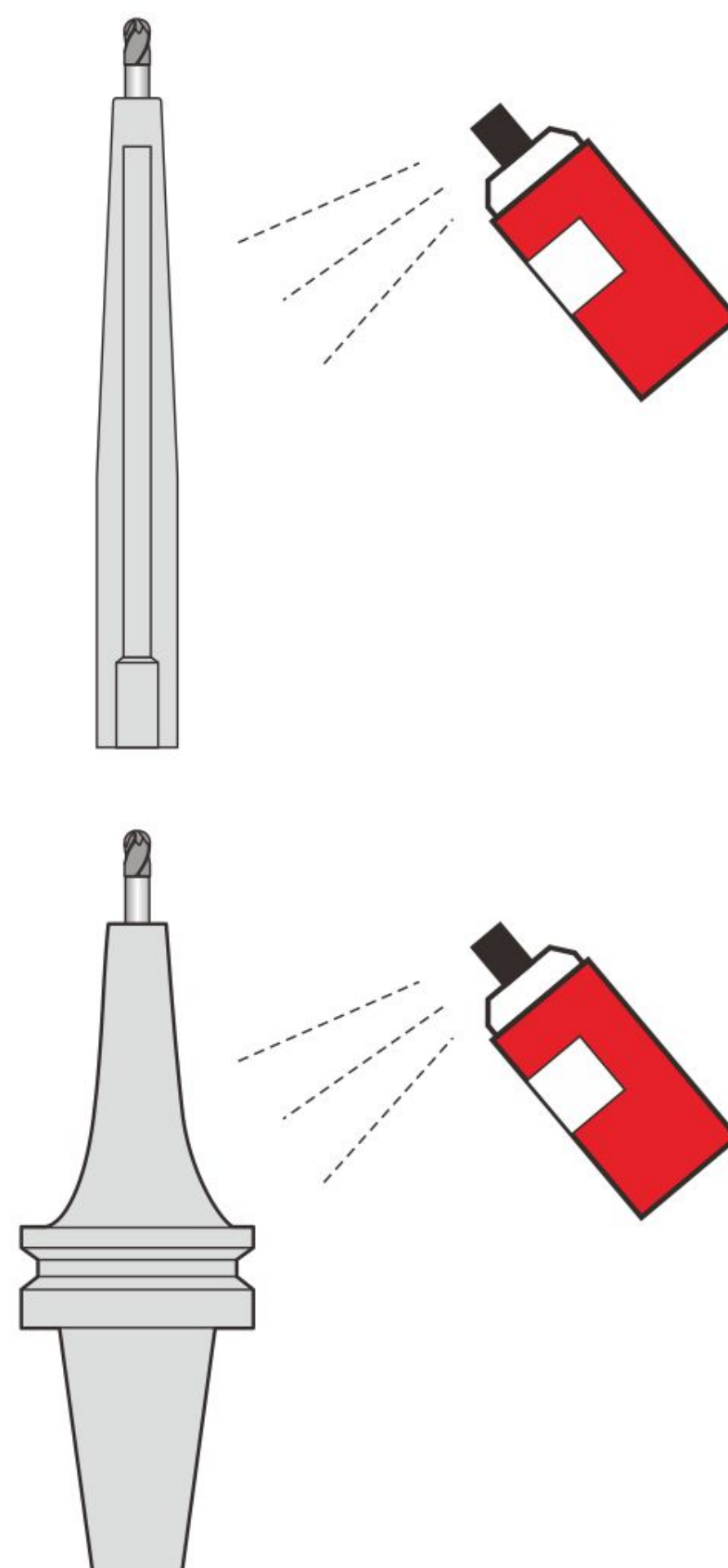

注意事项

- 热胀刀柄使用一段时间后，如装取困难，则需要进行刀柄保养，清除热胀刀柄内孔高温遗留的积碳。

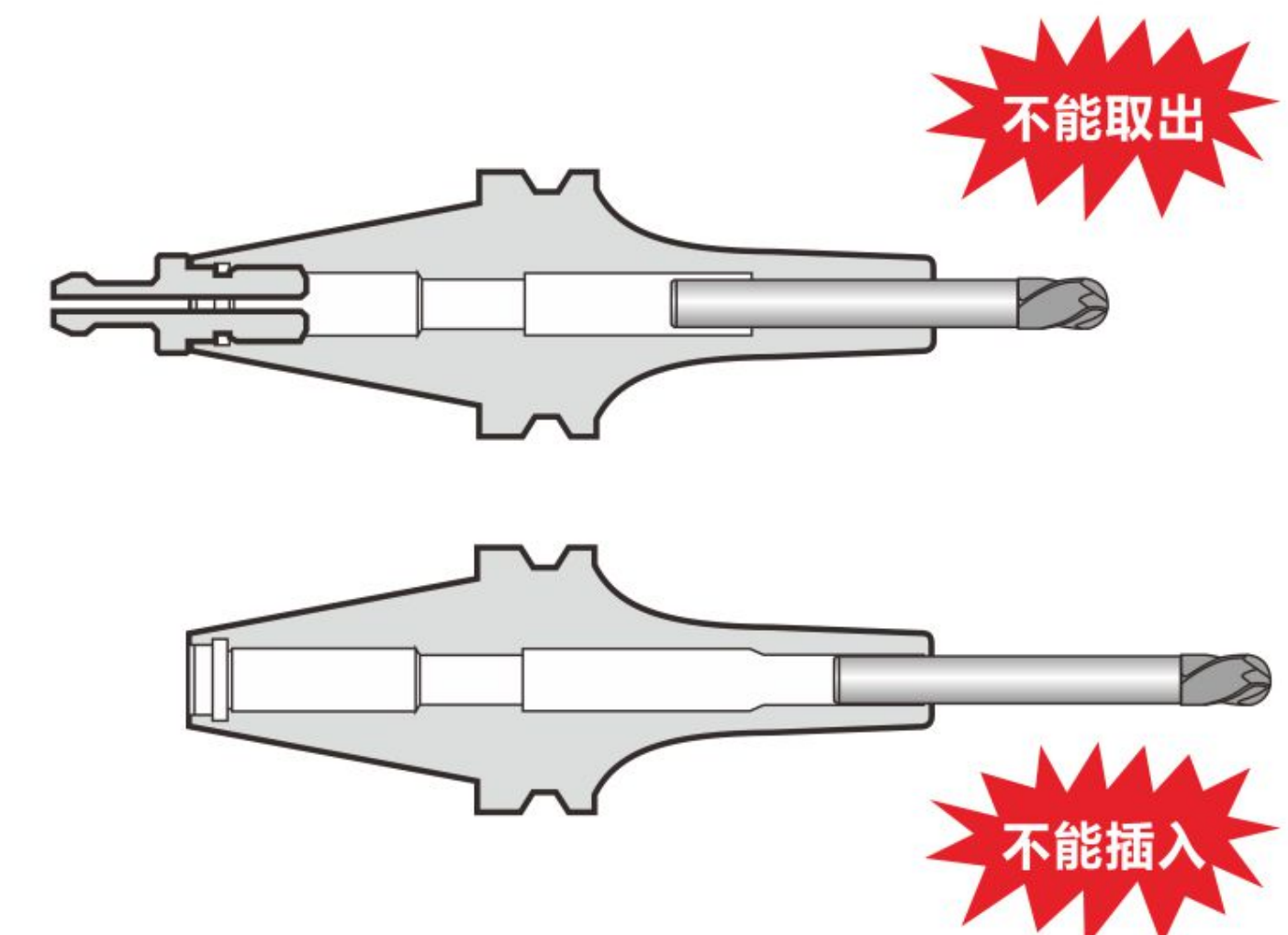

- 请使用内冷拉钉，否则请将拉钉取下后再进行加热。通常拉钉不排出空气就不能放入刀具。

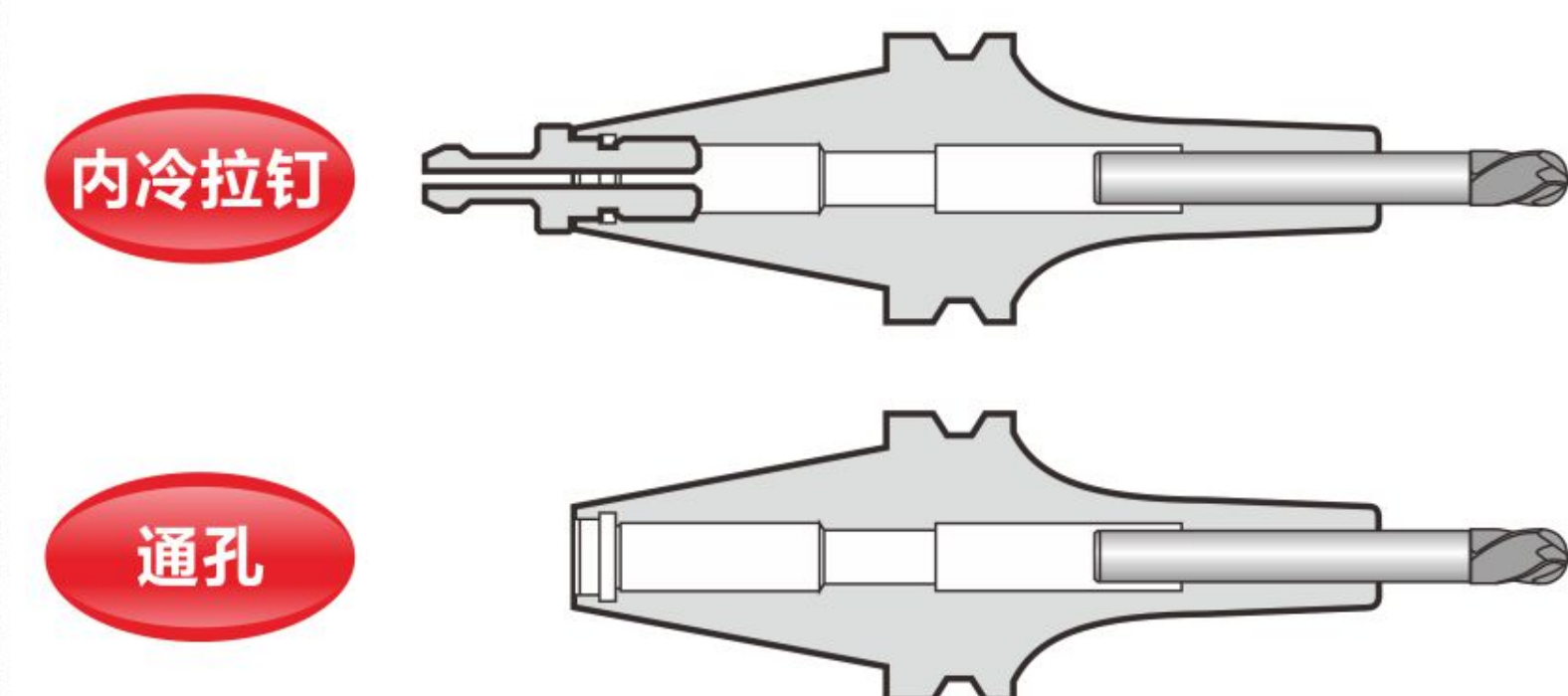

热胀工具系统

- 热胀刀柄采用了热胀冷缩的原理，用热感应装置使刀具的夹持部分在短时间内加热，刀柄内径扩张，然后将刀具装入刀柄中。刀柄冷却收缩，即可赋予刀柄均匀的夹持力。
- 刀具和刀柄间不介入任何机械夹持部件，因此可以解决高速加工中极为重要的平衡、跳动精度及夹紧强度等问题。

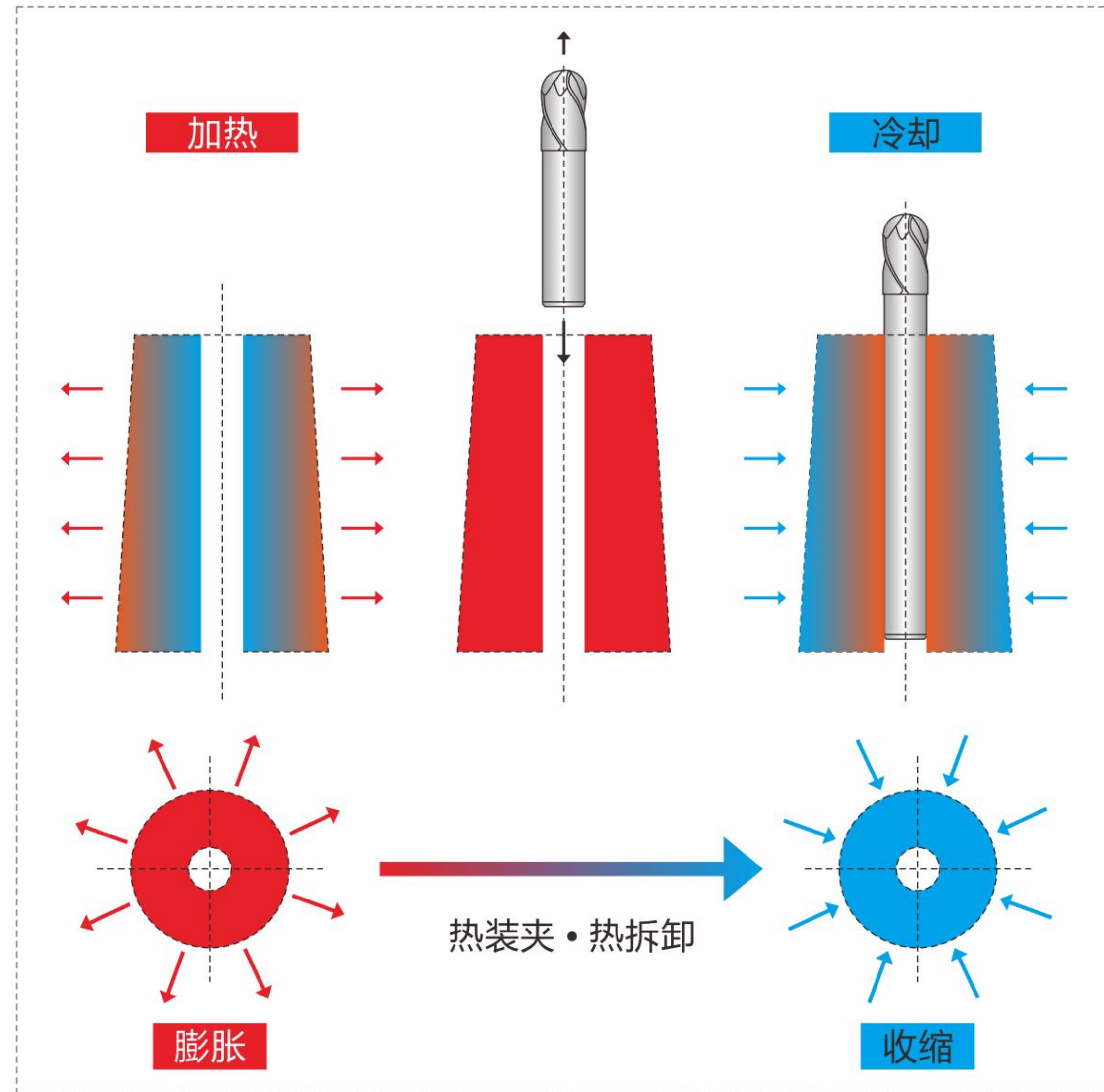

夹持范围公差

- 推荐热胀刀柄夹持圆柱柄的刀具。
- 直径 < 6mm 柄部公差为h5。
- 直径 ≥ 6mm 柄部公差为h6。
- 刀具材料必须使用硬质合金刀具，因为其他刀具材料的红硬性差，并且刀具与热胀刀柄的膨胀系数很接近，会造成热胀刀柄内的刀具不能正常取出，会影响刀柄的正常使用。

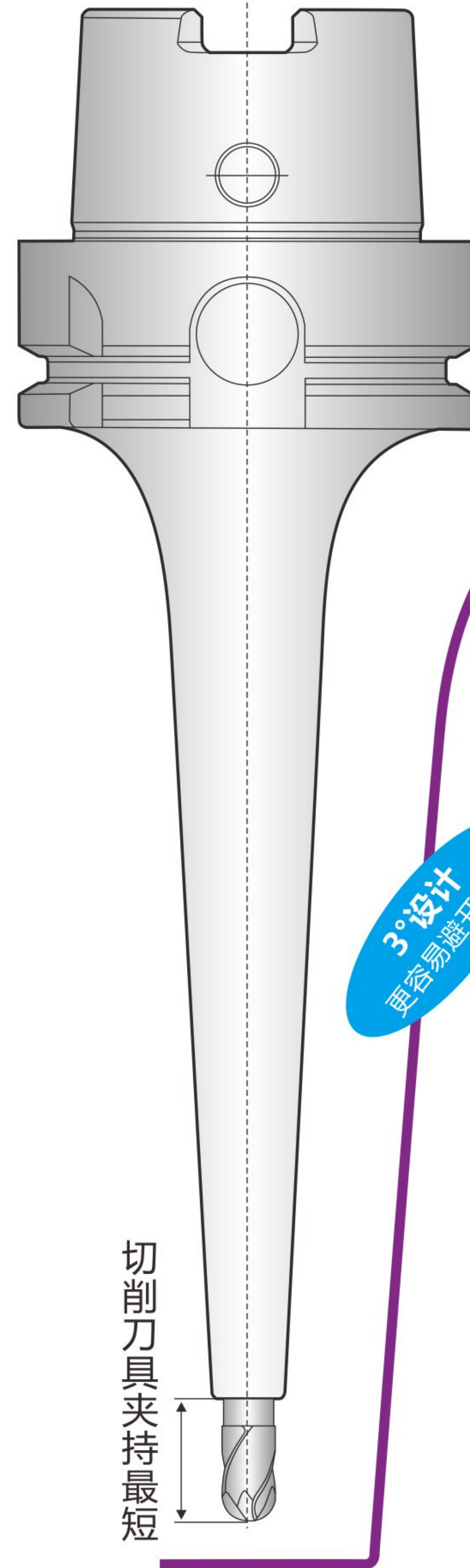

高刚性

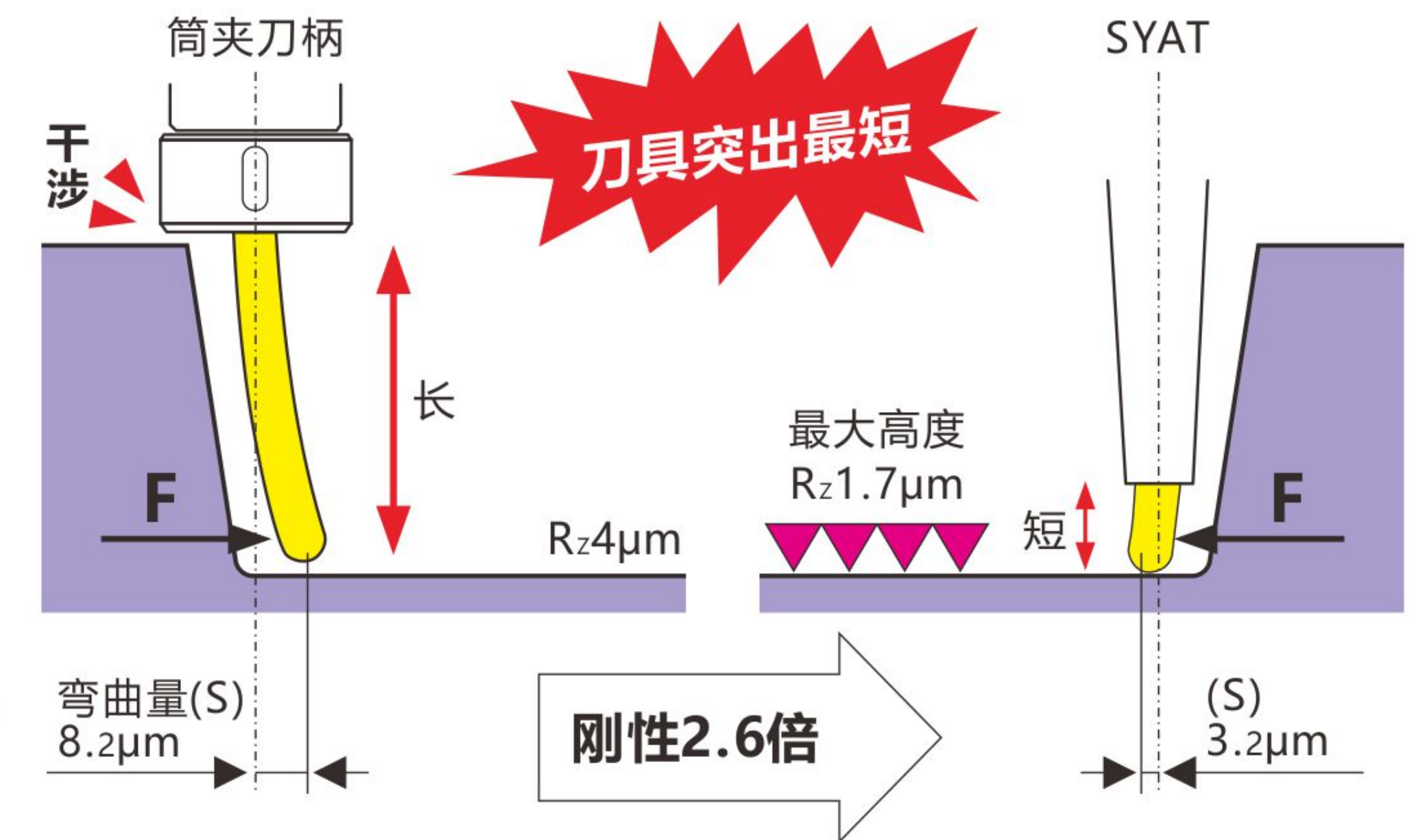

加工比较测试

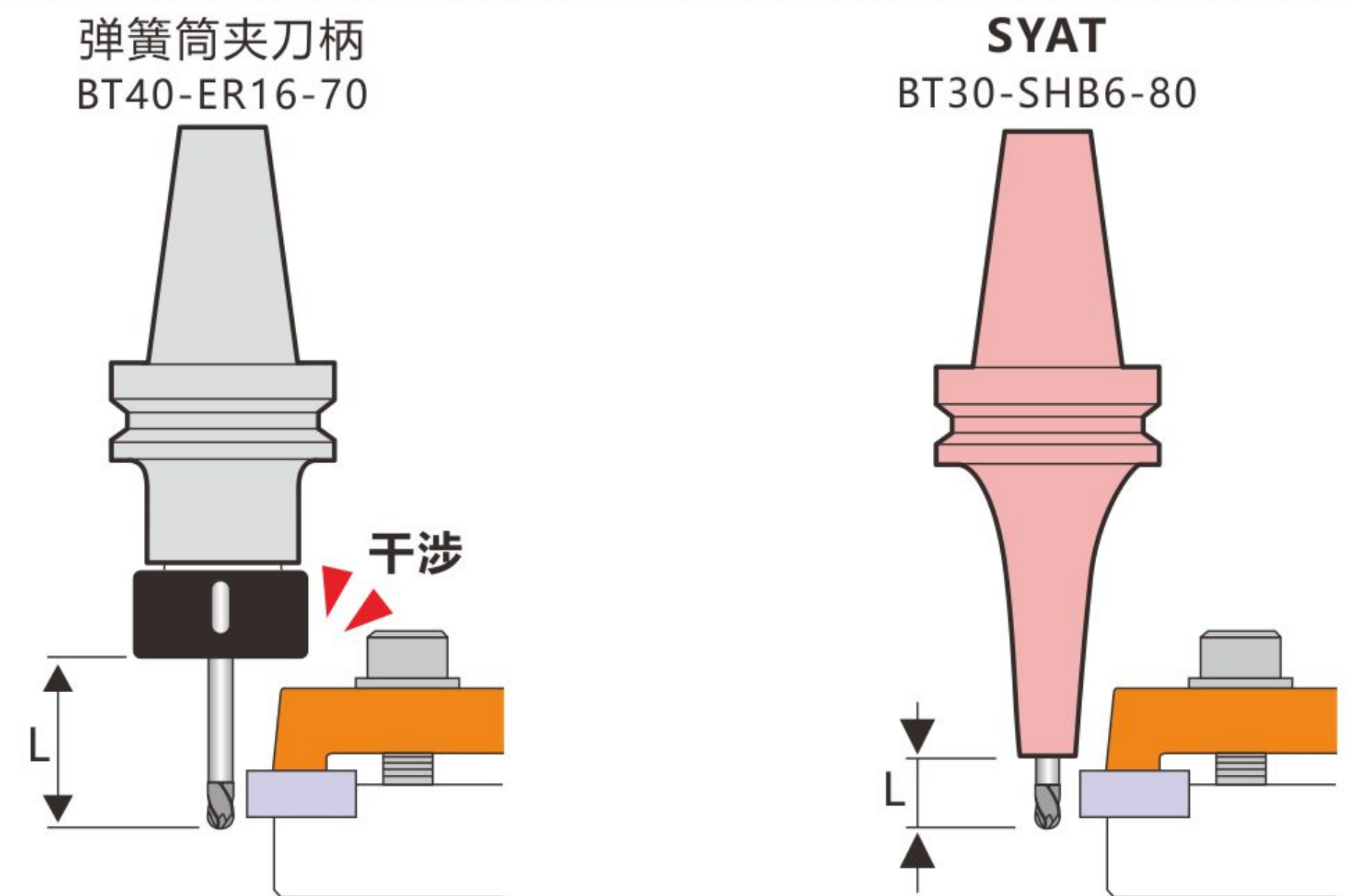

高夹持力

	筒夹刀柄	SYAT
[夹持原理]	通过筒夹的切割槽产生弹性形变来夹持刀具	利用了硬质合金刀具和刀柄的材料热膨胀系数之差， 强力并且稳定的夹持力
夹持力	21N·m(2.1kgf·m) 弹性形变 Φ6	62N·m(6.2kgf·m) 热膨胀→收缩力 Φ6 3倍

2体式-本体刀柄

MAS 403	Taper Accuracy	G Value	RPM	Coolant System
-BT/HSK	AT3	2.5	25000	



图1



图2

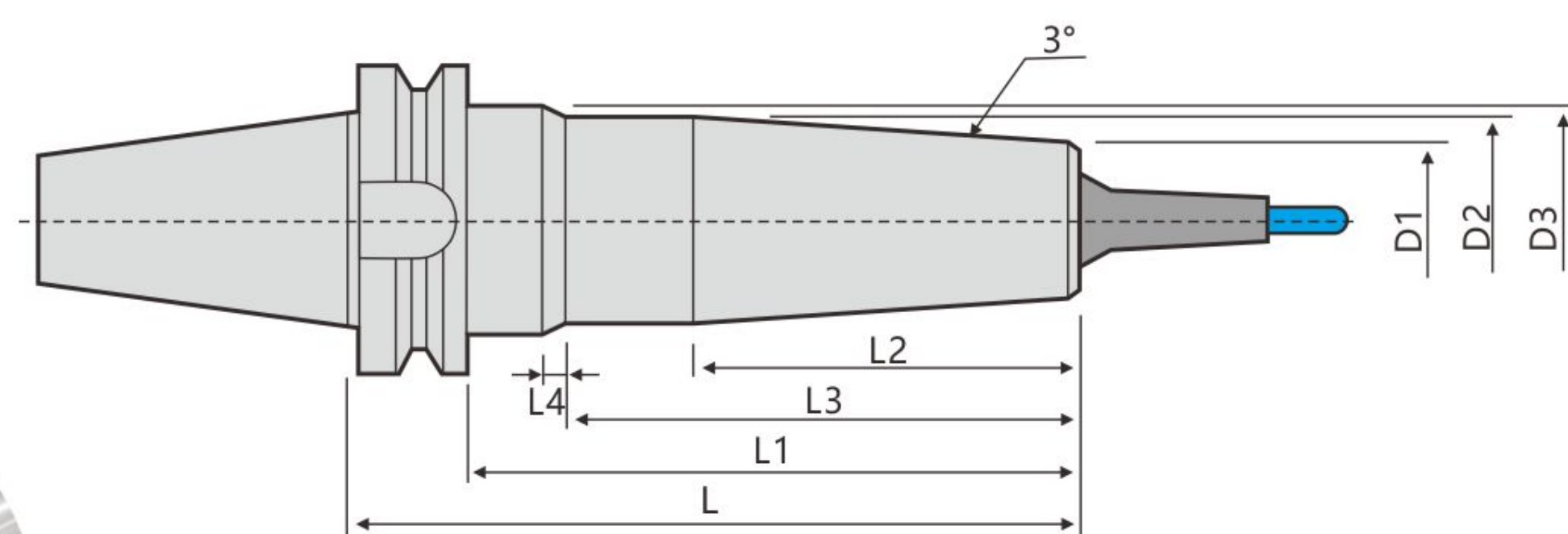

图3

● 库存 Stock

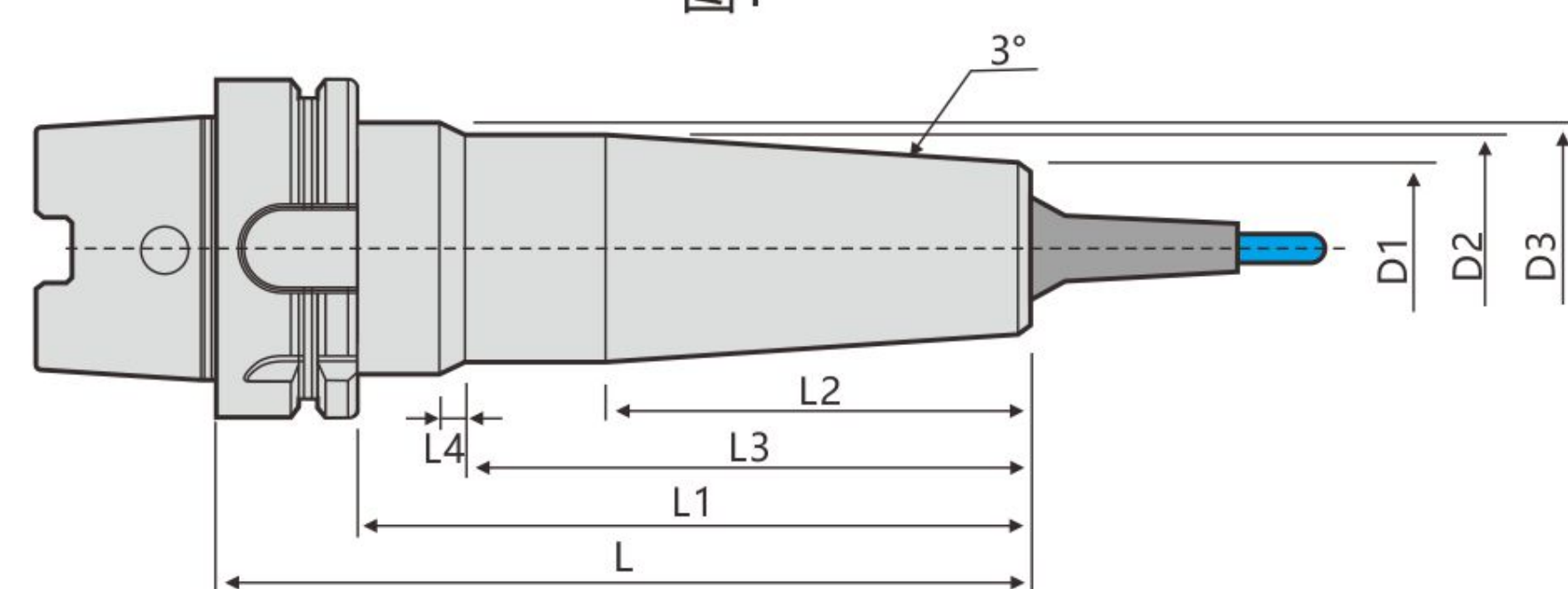
单位: mm

型号	图	D1	D2	D3	L	L1	L2	L3	L4	L5	库存
BT30-SLK12-45	1	38			45	23					●
BT40-SLK12-45		38			45	18					○
BT40-SLK12-75		38			75	48					●
BT40-SLK12-135		38	47		135	108	86				●
BT40-SLK12-225		38	47	52	225	198	86	140	5		○
BT50-SLK12-75	1	38	65		75	37	25			12	●
BT50-SLK12-105		38	65		105	67	55			12	●
BT50-SLK12-135		38	65		135	97	85			12	●
BT50-SLK12-225		38	65		225	187	150			37	○
HSK A63-SLK12-75	2	38			75	49					●
HSK A63-SLK12-135		38	47		135	109	86				●
HSK A63-SLK12-165		38	47		165	139	86				●
HSK A63-SLK12-200		38	47	52	200	174	86	140	5		●
HSK A63-SLK12-225		38	47	52	225	199	86	140	5		●
HSK A100-SLK12-105	3	38	65		105	76	43			33	●
HSK A100-SLK12-135		38	65		135	106	73			33	●
HSK A100-SLK12-225		38	83		225	196	163			33	●
HSK E50-SLK12-75	2	38			75	49					●
HSK E50-SLK12-120		38			120	94					●

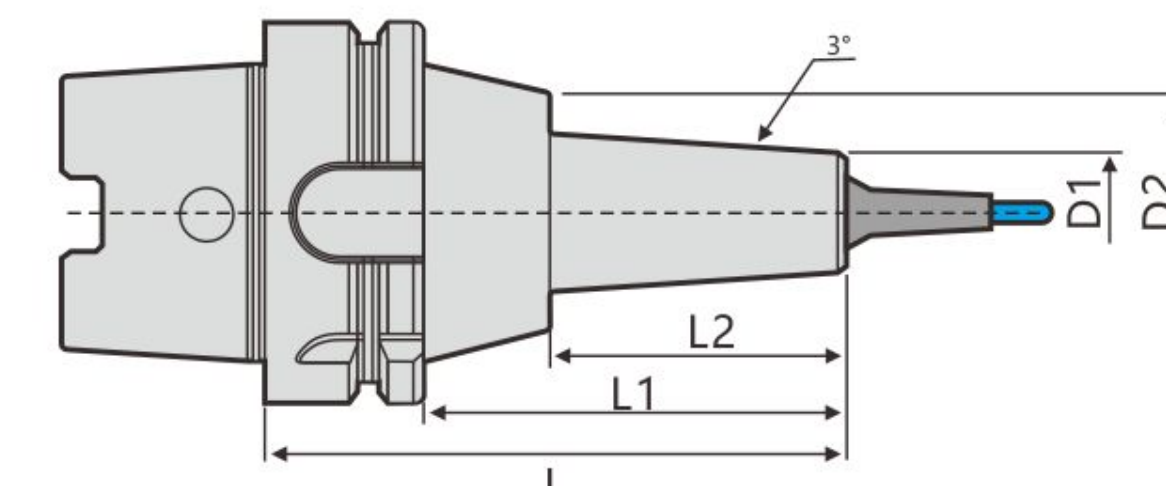
SCR12(高端系列) 不锈钢热胀筒夹

SCS12(高端系列) 不锈钢热胀筒夹



图1



图2

● 库存 Stock

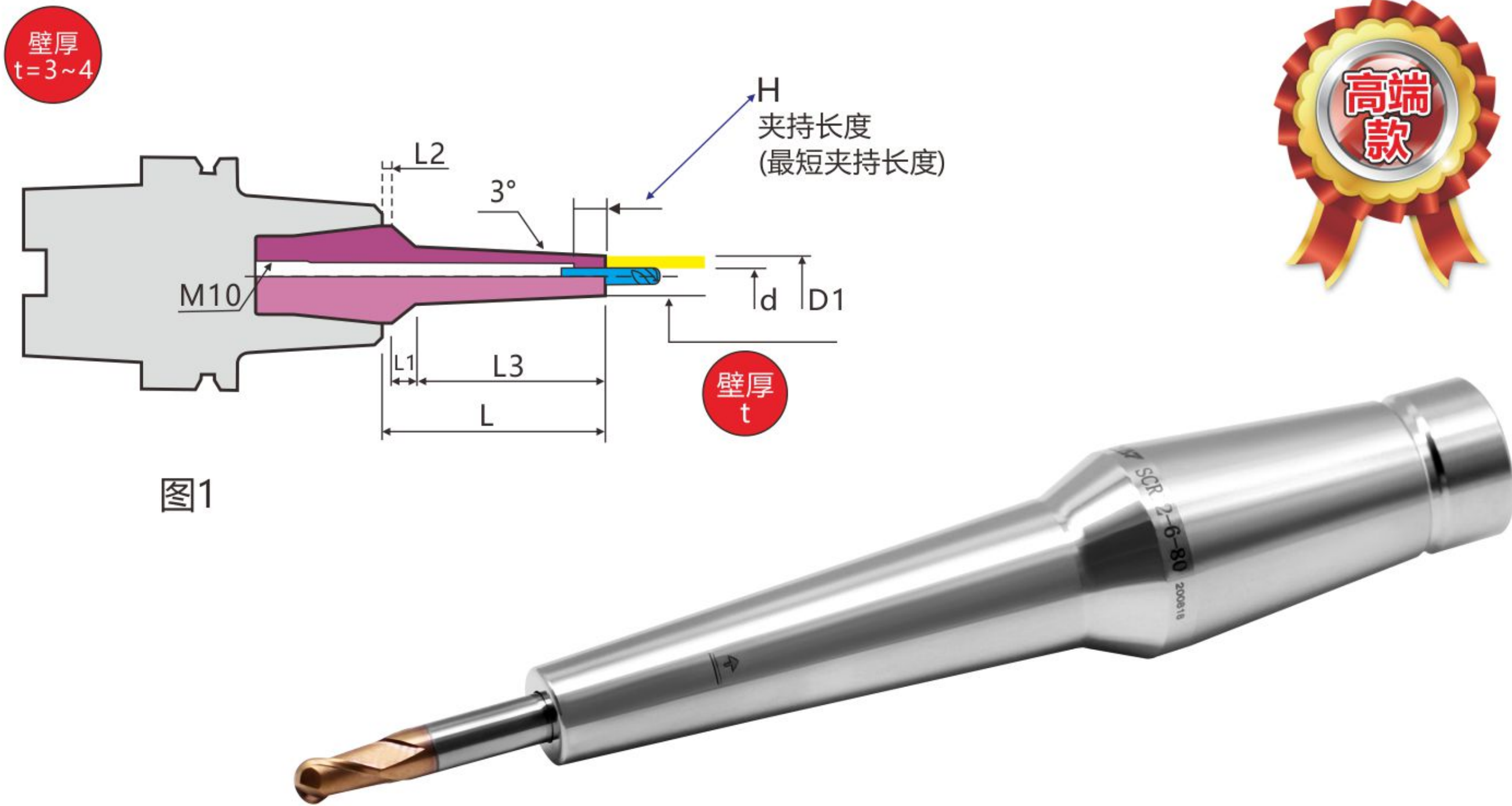
单位: mm

型号	图	d	D1	D2	壁厚 (t)	L	L1	L2	L3	L4	H	库存
SCR12-3-35	1	3	7.5		2.25	35	9.5	3.5	22		10	●
SCR12-3-55		3	7.5		2.25	55	9.5	3.5	42		10	●
SCR12-3-80		3	7.5		2.25	80	9.5	3.5	67		10	●
SCR12-3-110		3	7.5		2.25	110	9.5	3.5	97		10	●
SCR12-4-35		4	10		3	35	9.5	3.5	22		13	●
SCR12-4-55		4	10		3	55	9.5	3.5	42		13	●
SCR12-4-80		4	10		3	80	9.5	3.5	67		13	●
SCR12-4-110		4	10		3	110	9.5	3.5	97		13	●
SCR12-6-35		6	12		3	35	9.5	3.5	22		20	●
SCR12-6-55		6	12		3	55	9.5	3.5	42		20	●
SCR12-6-80	6	12		3	80	9.5	3.5	67		20	●	
SCR12-6-110	6	12		3	110	9.5	3.5	97		20	●	
SCR12-8-35	8	14		3	35	9.5	3.5	22		25	●	
SCR12-8-55	8	14		3	55	9.5	3.5	42		25	●	
SCR12-8-80	8	14		3	80	9.5	3.5	67		25	●	
SCR12-8-110	8	14		3	110	9.5	3.5	97		25	●	
SCR12-10-35	10	16		3	35	9.5	3.5	22	55	30	●	
SCR12-10-55	10	16		3	55	9.5	3.5	42	55	30	●	
SCR12-10-80	10	16		3	80	9.5	3.5	67	55	30	●	
SCR12-10-110	2	10	16	25	3	110	9.5	3.5	97	55	30	●
SCR12-12-35	1	12	20		4	35	9.5	3.5	22	55	30	●
SCR12-12-55	1	12	20		4	55	9.5	3.5	42	55	30	●
SCR12-12-80	2	12	20	25.5	4	80	—	3.5	—	55	30	●
SCR12-12-110	2	12	20	25.5	4	110	—	3.5	—	55	30	●

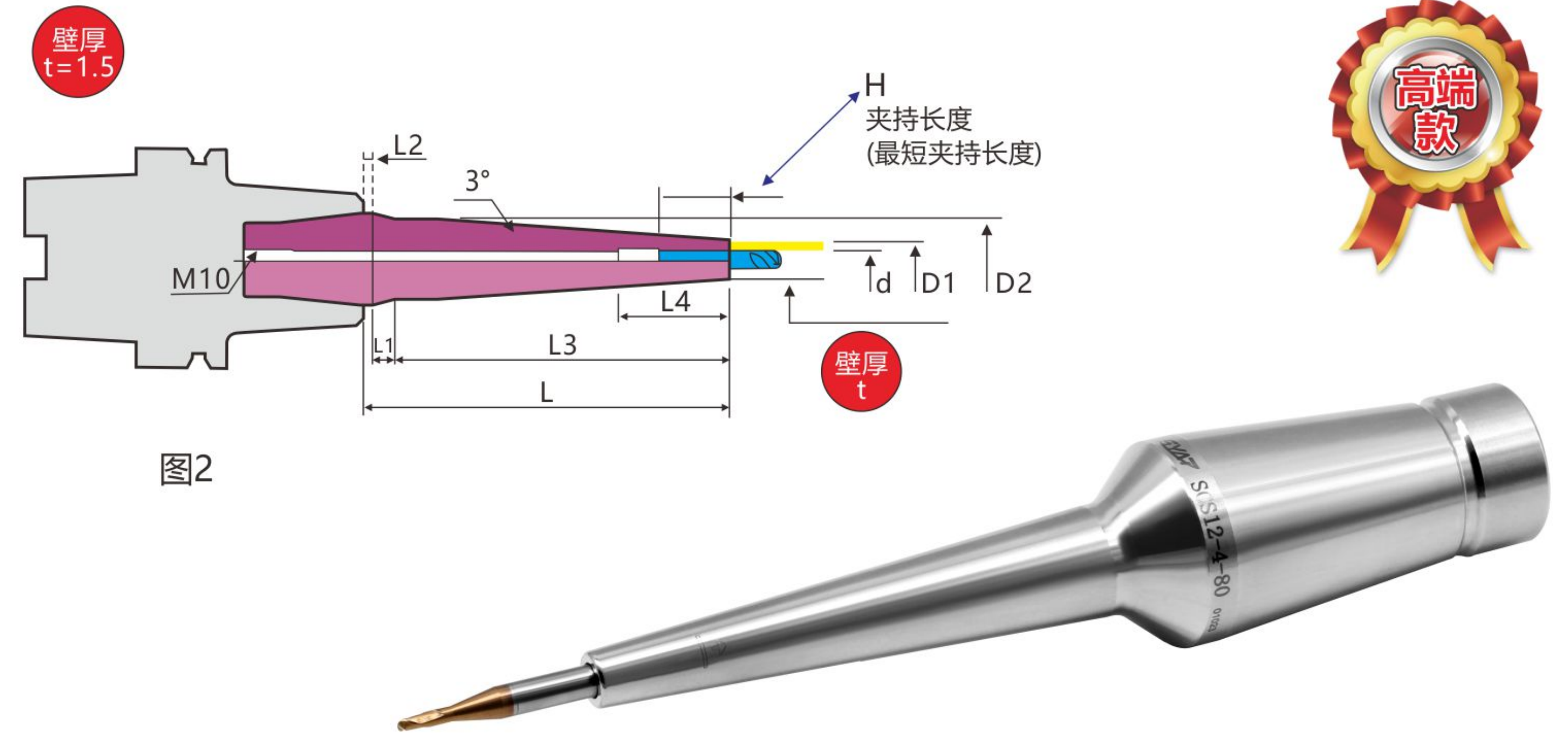
● 库存 Stock

单位: mm

型号	图	d	D1	D2	壁厚 (t)	L	L1	L2	L3	L4	H	库存
SCS12-3-35	1	3	6		1.5	35	9.5	3.5	22		10	●
SCS12-3-55		3	6		1.5	55	9.5	3.5	42		10	●
SCS12-3-80		3	6		1.5	80	9.5	3.5	67		10	●
SCS12-3-110		3	6		1.5	110	9.5	3.5	97		10	●
SCS12-4-35		4	7		1.5	35	9.5	3.5	22		13	●
SCS12-4-55		4	7		1.5	55	9.5	3.5	42		13	●
SCS12-4-80		4	7		1.5	80	9.5	3.5	67		13	●
SCS12-4-110		4	7		1.5	110	9.5	3.5	97		13	●
SCS12-6-35		6	9		1.5	35	9.5	3.5	22		20	●
SCS12-6-55		6	9		1.5	55	9.5	3.5	42		20	●
SCS12-6-80	6	9		1.5	80	9.5	3.5	67		20	●	
SCS12-6-110	1	6	9		1.5	110	9.5	3.5	97		20	●
SCS12-8-35	8	11		1.5	35	9.5	3.5	22		25	●	
SCS12-8-55	8	11		1.5	55	9.5	3.5	42		25	●	
SCS12-8-80	8	11		1.5	80	9.5	3.5	67		25	●	
SCS12-8-110	8	11		1.5	110	9.5	3.5	97		25	●	
SCS12-10-35	10	13		1.5	35	9.5	3.5	22	55	30	●	
SCS12-10-55	10	13		1.5	55	9.5	3.5	42	55	30	●	
SCS12-10-80	10	13		1.5	80	9.5	3.5	67	55	30	●	
SCS12-10-110	10	13		1.5	110	9.5	3.5	97	55	30	●	
SCS12-12-35	12	15		1.5	35	9.5	3.5	42	55	30	●	
SCS12-12-55	12	15		1.5	55	9.5	3.5	42	55	30	●	
SCS12-12-80	2	12	15	25	1.5	80	9.5	3.5	67	55	30	●
SCS12-12-110	2	12	15	25	1.5	110	—	3.5	—	55	30	●

DCR12(热销系列) 不锈钢热胀筒夹

DCS12(热销系列) 不锈钢热胀筒夹



图1



图2

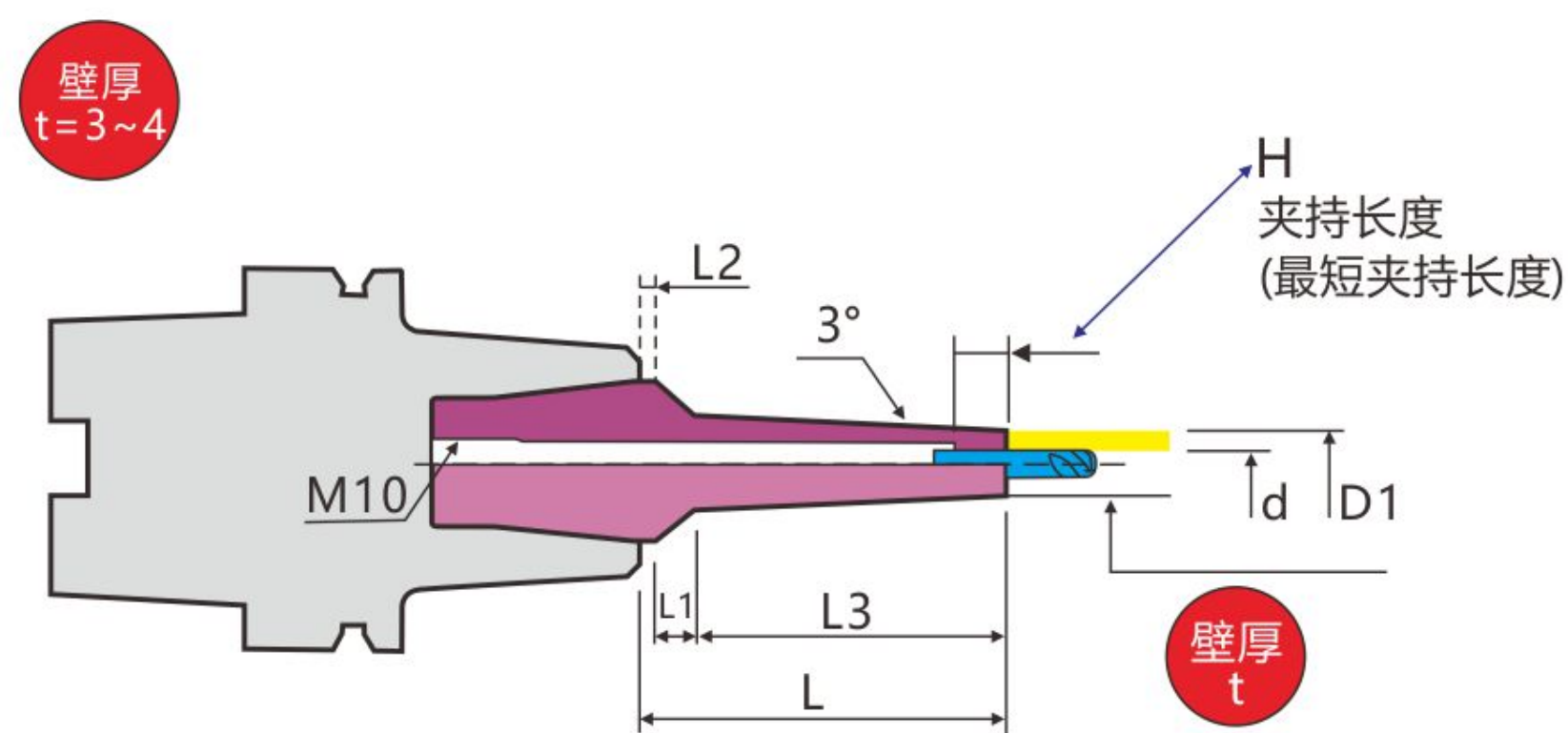

● 库存 Stock

单位: mm

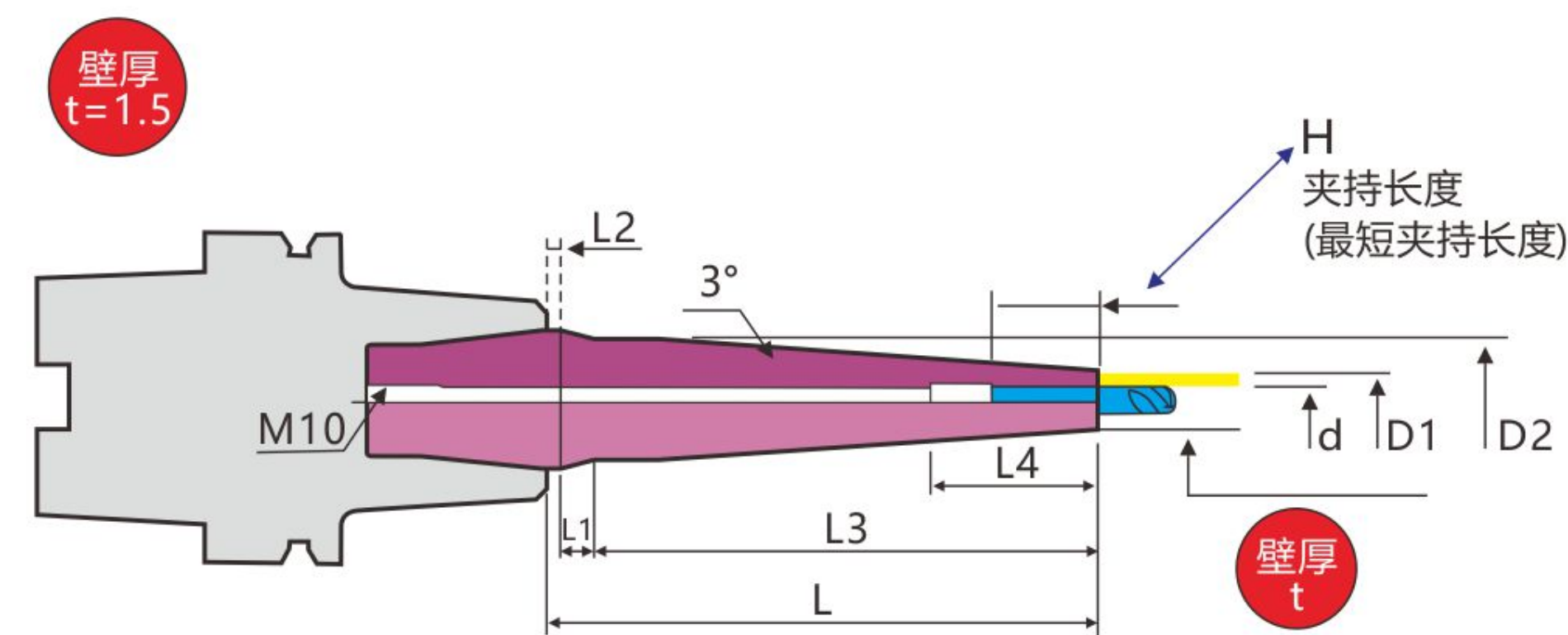
型号	图	d	D1	D2	壁厚 (t)	L	L1	L2	L3	L4	H	库存
DCR12-3-35	1	3	7.5		2.25	35	9.5	3.5	22		10	●
DCR12-3-55		3	7.5		2.25	55	9.5	3.5	42		10	●
DCR12-3-80		3	7.5		2.25	80	9.5	3.5	67		10	●
DCR12-3-110		3	7.5		2.25	110	9.5	3.5	97		10	●
DCR12-4-35		4	10		3	35	9.5	3.5	22		13	●
DCR12-4-55		4	10		3	55	9.5	3.5	42		13	●
DCR12-4-80		4	10		3	80	9.5	3.5	67		13	●
DCR12-4-110		4	10		3	110	9.5	3.5	97		13	●
DCR12-6-35		6	12		3	35	9.5	3.5	22		20	●
DCR12-6-55		6	12		3	55	9.5	3.5	42		20	●
DCR12-6-80	6	12		3	80	9.5	3.5	67		20	●	
DCR12-6-110	6	12		3	110	9.5	3.5	97		20	●	
DCR12-8-35	8	14		3	35	9.5	3.5	22		25	●	
DCR12-8-55	8	14		3	55	9.5	3.5	42		25	●	
DCR12-8-80	8	14		3	80	9.5	3.5	67		25	●	
DCR12-8-110	8	14		3	110	9.5	3.5	97		25	●	
DCR12-10-35	10	16		3	35	9.5	3.5	22	55	30	●	
DCR12-10-55	10	16		3	55	9.5	3.5	42	55	30	●	
DCR12-10-80	10	16		3	80	9.5	3.5	67	55	30	●	
DCR12-10-110	2	10	16	25	3	110	9.5	3.5	97	55	30	●
DCR12-12-35	1	12	20		4	35	9.5	3.5	22	55	30	●
DCR12-12-55	1	12	20		4	55	9.5	3.5	42	55	30	●
DCR12-12-80	2	12	20	25.5	4	80	—	3.5	—	55	30	●
DCR12-12-110	2	12	20	25.5	4	110	—	3.5	—	55	30	●

● 库存 Stock

单位: mm

型号	图	d	D1	D2	壁厚 (t)	L	L1	L2	L3	L4	H	库存
DCS12-3-35	1	3	6		1.5	35	9.5	3.5	22		10	●
DCS12-3-55		3	6		1.5	55	9.5	3.5	42		10	●
DCS12-3-80		3	6		1.5	80	9.5	3.5	67		10	●
DCS12-3-110		3	6		1.5	110	9.5	3.5	97		10	●
DCS12-4-35		4	7		1.5	35	9.5	3.5	22		13	●
DCS12-4-55		4	7		1.5	55	9.5	3.5	42		13	●
DCS12-4-80		4	7		1.5	80	9.5	3.5	67		13	●
DCS12-4-110		4	7		1.5	110	9.5	3.5	97		13	●
DCS12-6-35		6	9		1.5	35	9.5	3.5	22		20	●
DCS12-6-55		6	9		1.5	55	9.5	3.5	42		20	●
DCS12-6-80	6	9		1.5	80	9.5	3.5	67		20	●	
DCS12-6-110	1	6	9		1.5	110	9.5	3.5	97		20	●
DCS12-8-35	8	11		1.5	35	9.5	3.5	22		25	●	
DCS12-8-55	8	11		1.5	55	9.5	3.5	42		25	●	
DCS12-8-80	8	11		1.5	80	9.5	3.5	67		25	●	
DCS12-8-110	8	11		1.5	110	9.5	3.5	97		25	●	
DCS12-10-35	10	13		1.5	35	9.5	3.5	22	55	30	●	
DCS12-10-55	10	13		1.5	55	9.5	3.5	42	55	30	●	
DCS12-10-80	10	13		1.5	80	9.5	3.5	67	55	30	●	
DCS12-10-110	10	13		1.5	110	9.5	3.5	97	55	30	●	
DCS12-12-35	12	15		1.5	35	9.5	3.5	42	55	30	●	
DCS12-12-55	12	15		1.5	55	9.5	3.5	42	55	30	●	
DCS12-12-80	2	12	15		1.5	80	9.5	3.5	67	55	30	●
DCS12-12-110	2	12	15	25	1.5	110	—	3.5	—	55	30	●

热胀延长杆(深腔型 不锈钢材质)

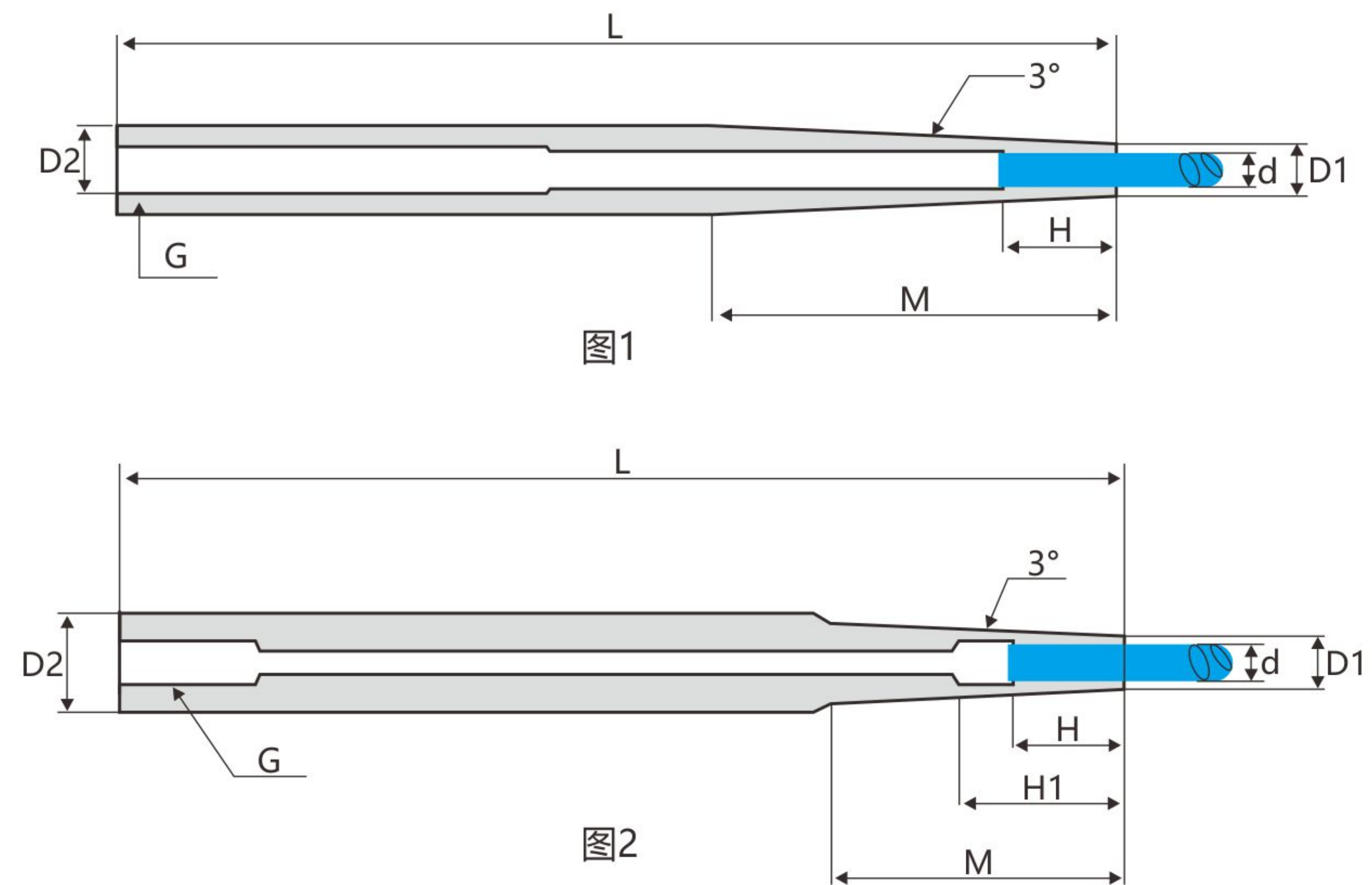

● 库存 Stock

单位: mm

型号	图	d	D1	D2	壁厚 (t)	L	G	H	H1	M	库存
ST10-SHSB4-100-M19	1	4	8	10	2	100	—	13	—	19	●
ST12-SHSB3-115-M47	1	3	7	12	2	115	—	10	—	47	●
ST12-SHSA4-115-M47		4	7	12	1.5	115	—	13	—	47	●
ST12-SHSB4-115-M38		4	8	12	2	115	—	13	—	38	●
ST12-SHSB6-115-M19		6	10	12	2	115	—	13	—	19	●
ST16-SHSA4-115-M42		2	4	7	16	1.5	115	M10	13	—	42
ST16-SHRA4-115-M57	1	4	10	16	3	115	M10	13	—	57	●
ST16-SHSA4-150-M86		4	7	16	1.5	150	M10	13	—	86	●
ST16-SHRA4-150-M57		4	10	16	3	150	M10	13	—	57	●
ST16-SHSB6-115-M57		6	10	16	2	115	M10	19	—	57	●
ST16-SHRA6-115-M38		6	12	16	3	115	M10	19	—	38	●
ST16-SHSB6-150-M57		6	10	16	2	150	M10	19	—	57	●
ST16-SHRA6-150-M38		6	12	16	3	150	M10	19	—	38	●
ST16-SHSA8-150-M50		8	11	16	1.5	150	M10	25	—	50	●
ST16-SHSB8-150-M28		8	13	16	2.5	150	M10	25	—	28	●

型号	图	d	D1	D2	壁厚 (t)	L	G	H	H1	M	库存	
ST20-SHRA4-145-M80	1	4	10	20	3	145	M10	13	—	80	●	
ST20-SHRA4-175-M95		4	10	20	3	175	M10	13	—	95	●	
ST20-SHRB6-145-M80		6	10	20	3	145	M10	19	—	80	●	
ST20-SHRA6-145-M76		6	12	20	3	145	M10	19	—	76	●	
ST20-SHRA6-175-M76		6	12	20	3	175	M10	19	—	76	●	
ST20-SHRA8-145-M57		8	14	20	3	145	M10	25	—	57	●	
ST20-SHRA8-175-M57		8	14	20	3	175	M10	25	—	57	●	
ST20-SHRA10-150-M50		10	16	20	3	150	M10	30	60	50	●	
ST25-SHRA6-150-M67		2	6	12	25	3	150	M10	19	—	67	●
ST25-SHRA6-200-M97			6	12	25	3	200	M10	19	—	97	●
ST25-SHRA8-150-M67	1	8	14	25	3	150	M10	25	—	67	●	
ST25-SHRA8-200-M105		8	14	25	3	200	M10	25	—	105	●	
ST25-SHSB10-150-M67		2	10	16	25	3	150	M10	30	60	67	●
ST25-SHSB10-200-M105	1	10	16	25	3	200	M10	30	60	105	●	
ST25-SHSB12-150-M80		12	19	25	3.5	150	M10	30	60	80	●	
ST25-SHSB12-200-M80		12	19	25	3.5	200	M10	30	60	80	●	

热胀延长杆(深腔型 合金钢材质)

MAS 403	Taper Accuracy	G Value	RPM	Coolant System
	AT3			

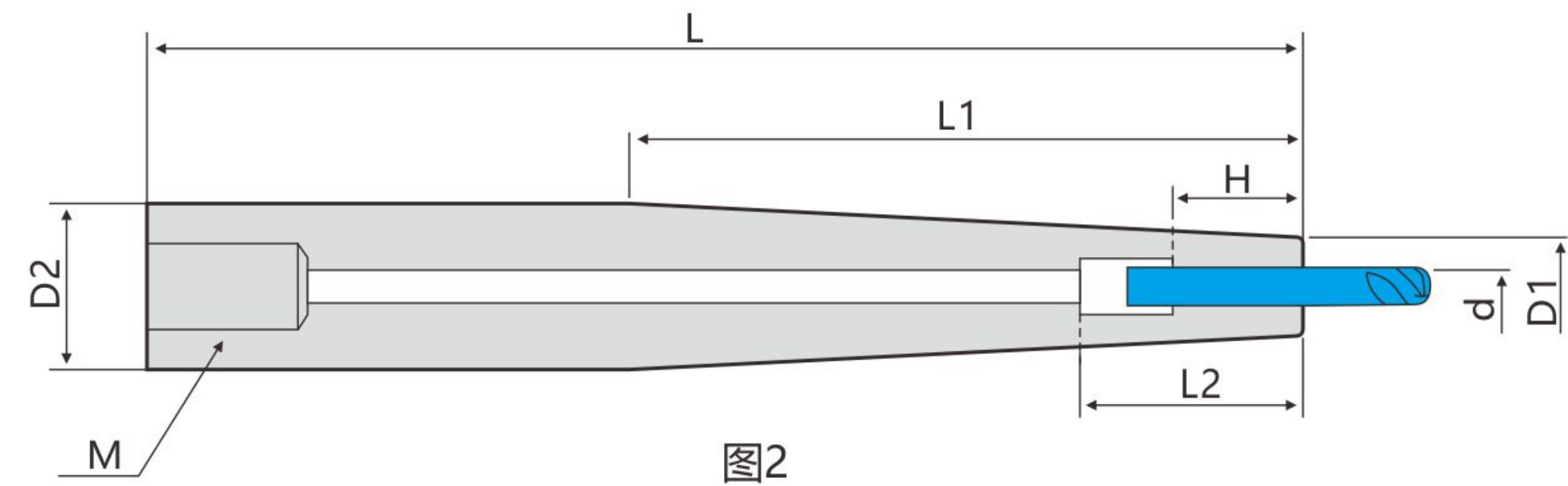
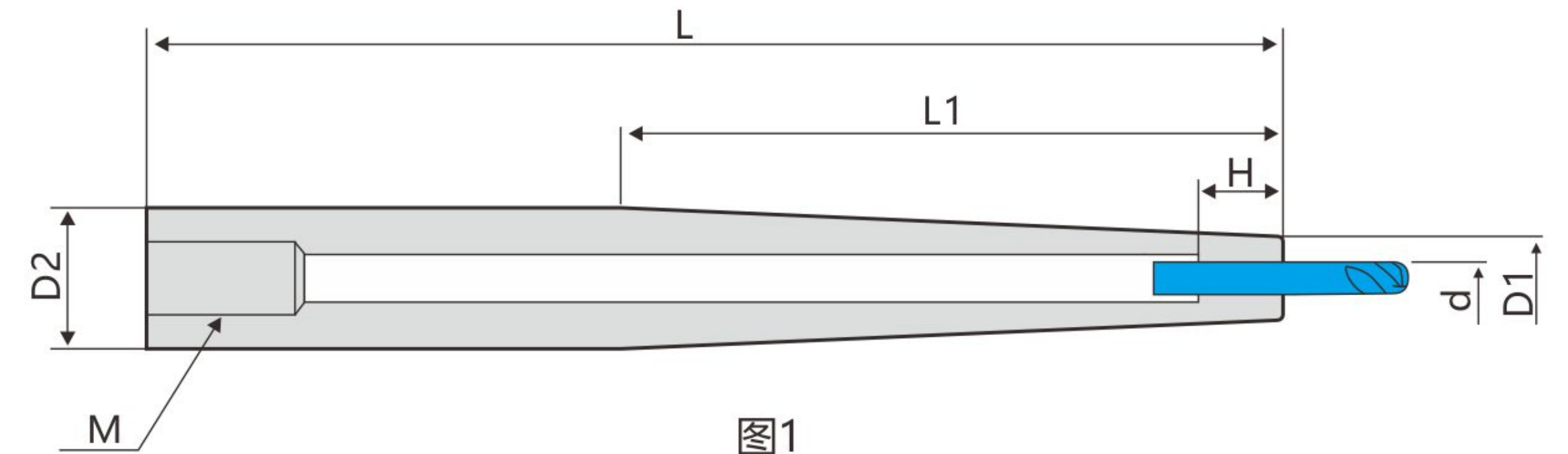

● 库存 Stock

单位: mm

型号	图	d	D1	D2	D3	壁厚 (t)	L	L1	L2	L3	H	M	库存
ST12-SHB4-120-M55	1	4	8	12		2	120	55			13	M8	●
ST12-SHB6-120-M55		6	10	12		2	120	55			20	M8	●
ST16-SHB4-120-M55		4	9	16		2.5	120	55			13	M10	●
ST16-SHB4-160-M75		4	9	16		2.5	160	75			13	M10	●
ST16-SHB6-120-M55		6	11	16		2.5	120	55			20	M10	●
ST16-SHB6-160-M75		6	11	16		2.5	160	75			20	M10	●
ST16-SHB8-120-M55		8	13	16		2.5	120	55			25	M10	●
ST16-SHB8-160-M75		8	13	16		2.5	160	75			25	M10	●
ST20-SHB4-160-M75		4	10	20		3	160	75			13	M10	●
ST20-SHB4-200-M95		4	10	20		3	200	95			13	M10	●
ST20-SHB6-120-M55		6	12	20		3	120	55			20	M10	●
ST20-SHB6-160-M75		6	12	20		3	160	75			20	M10	●
ST20-SHB6-200-M95		6	12	20		3	200	95			20	M10	●
ST20-SHB8-120-M55		8	14	20		3	120	55			25	M10	●
ST20-SHB8-160-M75		8	14	20		3	160	75			25	M10	●
ST20-SHB8-200-M75		8	14	20		3	200	75			25	M10	●

型号	图	d	D1	D2	D3	壁厚 (t)	L	L1	L2	L3	H	M	库存
ST20-SHB10-120-M55	2	10	16	20		3	120	55	55		30	M10	●
ST20-SHB10-160-M75		10	16	20		3	160	75	55		30	M10	●
ST25-SHB8-160-M75	1	8	14	25		3	160	75			25	M10	●
ST25-SHB8-200-M95		8	14	25		3	200	95			25	M10	●
ST25-SHB10-160-M75	2	10	16	25		3	160	75	55		30	M10	●
ST25-SHB10-200-M95		10	16	25		3	200	95	55		30	M10	●
ST25-SHB12-120-M55		12	19	25		3.5	120	55	55		30	M10	●
ST25-SHB12-160-M75	2	12	19	25		3.5	160	75	55		30	M10	●
ST25-SHB12-200-M95		12	20	25		4	200	95	55		30	M10	●
ST32-SHB8-160-M75		1	8	14	32		3	160	75			25	M10
ST32-SHB8-200-M95	8		14	32		3	200	95			25	M10	○
ST32-SHB10-160-M75	2	10	17	32		3.5	160	75	55		30	M10	○
ST32-SHB10-200-M95		10	17	32		3.5	200	95	55		30	M10	○
ST32-SHB12-160-M75		12	19	32		3.5	160	75	55		30	M10	○
ST32-SHB12-200-M95		12	20	32		4	200	95	55		30	M10	○
ST32-SHB16-160-M75		16	24	32		4	160	75	55		32	M10	○

BT30 整体式热胀刀柄(不锈钢材质)

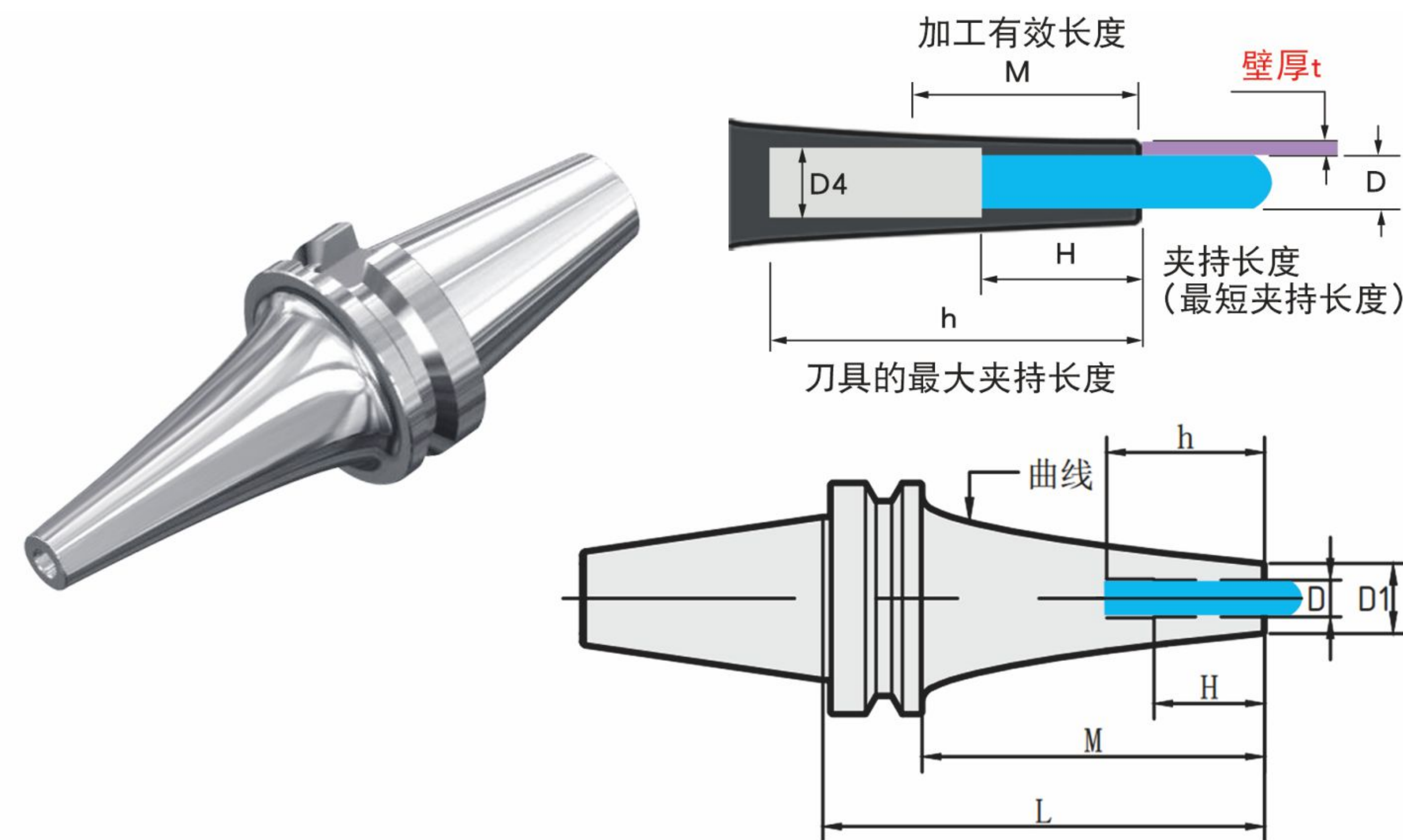
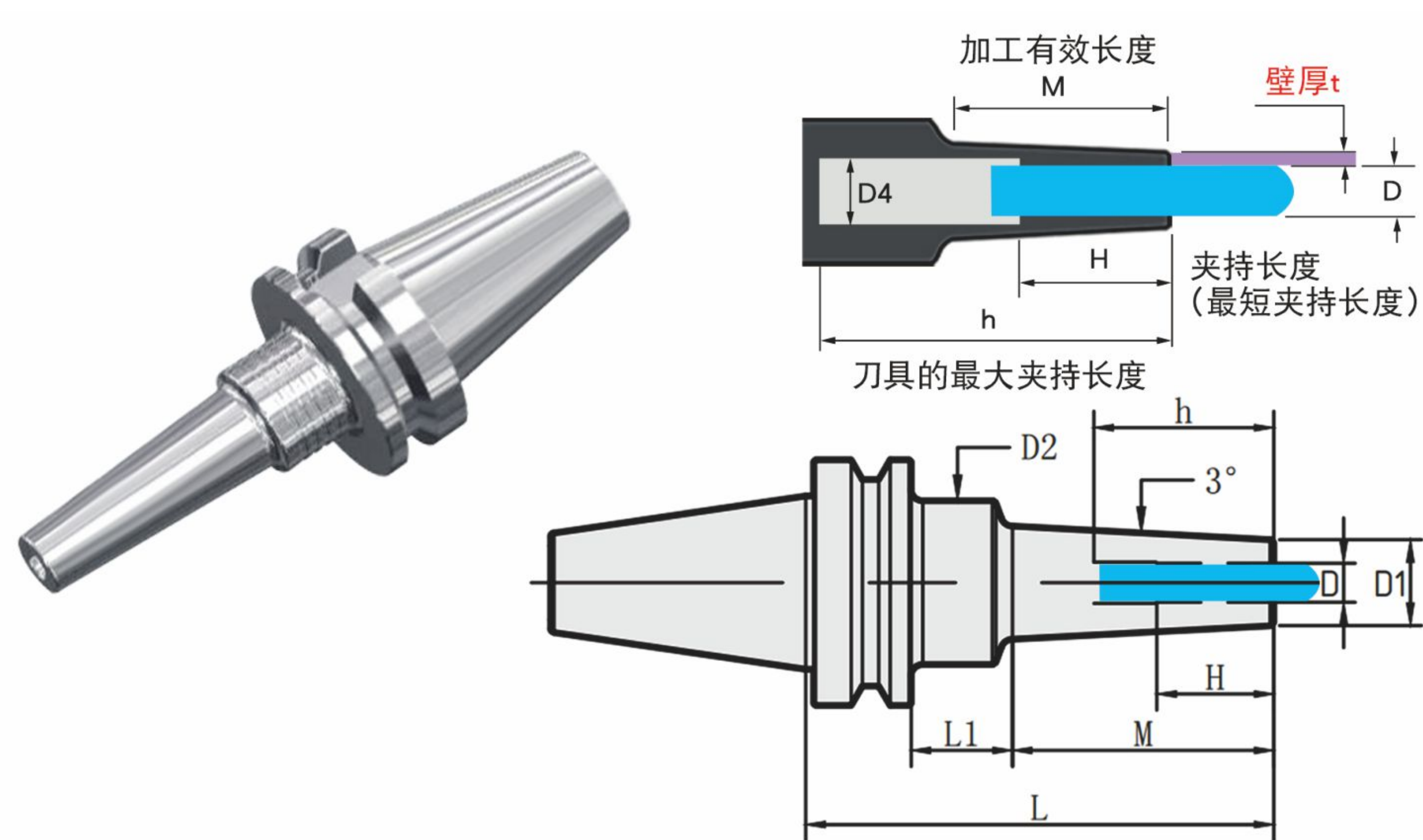

● 为常备库存 ○ 为少量库存

型号	D	D1	t	L	M	L1	L2	D2	D4	H	h	库存	
BT30 SHSA4- 60-M 22	4	7	1.5	60	22	16	-	20	5	12	80	●	
- 75-M 22				75		31		25				99	●
- 95-M 42				95	42							119	●
-120-M 67				120	67							144	●
BT30 SHRA4- 75-M 22	4	10	3	75	22	31	-	25	5	12	99	●	
BT30 SHSA6- 60-M 22	6	9	1.5	60	22	16	-	20	7	18	80	●	
- 75-M 22				75		31		25				99	●
- 95-M 42				95	42							119	●
-120-M 67				120	67							144	●
BT30 SHRA6- 75-M 22	6	12	3	75	22	31	-	25	7	18	99	●	
BT30 SHRA8- 75-M 22		14		75		31		25		24		●	
BT30 SHRA10- 75-M 22	10	16	3	75	22	31	-	25	11	30	99	●	
BT30 SHRA12- 75-M 22	12	20	4	75	22	31		25	13	30	99	●	
BT30 SHRA16- 60-M 22	16	26	5	60	22	16		34	16.6	32	60	●	
BT30 SHRA20- 65-M 22	20	32	6	65	22	21		40	20.6	38	60	●	

型号	D	D1	t	L	M	C1	D4	D2	D3	H	h	库存	
BT30 SHSA4- 75 CV	4	7	1.5	75	54	34	5	-	-	13	100	●	
- 90 CV				90	68							114	●
-120 CV				120	98							144	○
BT30 SHRA4- 90 CV	4	10	3	90	68	34	5	-	-	13	114	●	
-120 CV				120	98						144	○	
BT30 SHSA6- 75 CV	6	9	1.5	75	54	34	7	-	-	18	100	●	
- 90 CV				90	68						114	●	
-120 CV				120	98						144	○	
BT30 SHRA6- 90 CV	6	13	3.5	90	68	34	7	-	-	18	114	●	
-120 CV				120	98						144	○	
BT30 SHSA8- 75 CV	8	11	1.5	75	54	34	9	-	-	24	100	●	
- 90 CV				90	68						114	●	
BT30 SHRA8- 90 CV	8	16	4	90	68	34	9	-	-	24	144	●	
BT30 SHSA10- 75 CV	10	13	1.5	75	54	34	11	-	-	30	100	●	
- 90 CV				90	68						114	●	
BT30 SHRA10- 90 CV	10	19	4.5	90	68	34	11	-	-	30	114	●	

BT40 整体式热胀刀柄(不锈钢材质)



图1



图2

● 为常备库存 ○ 为少量库存

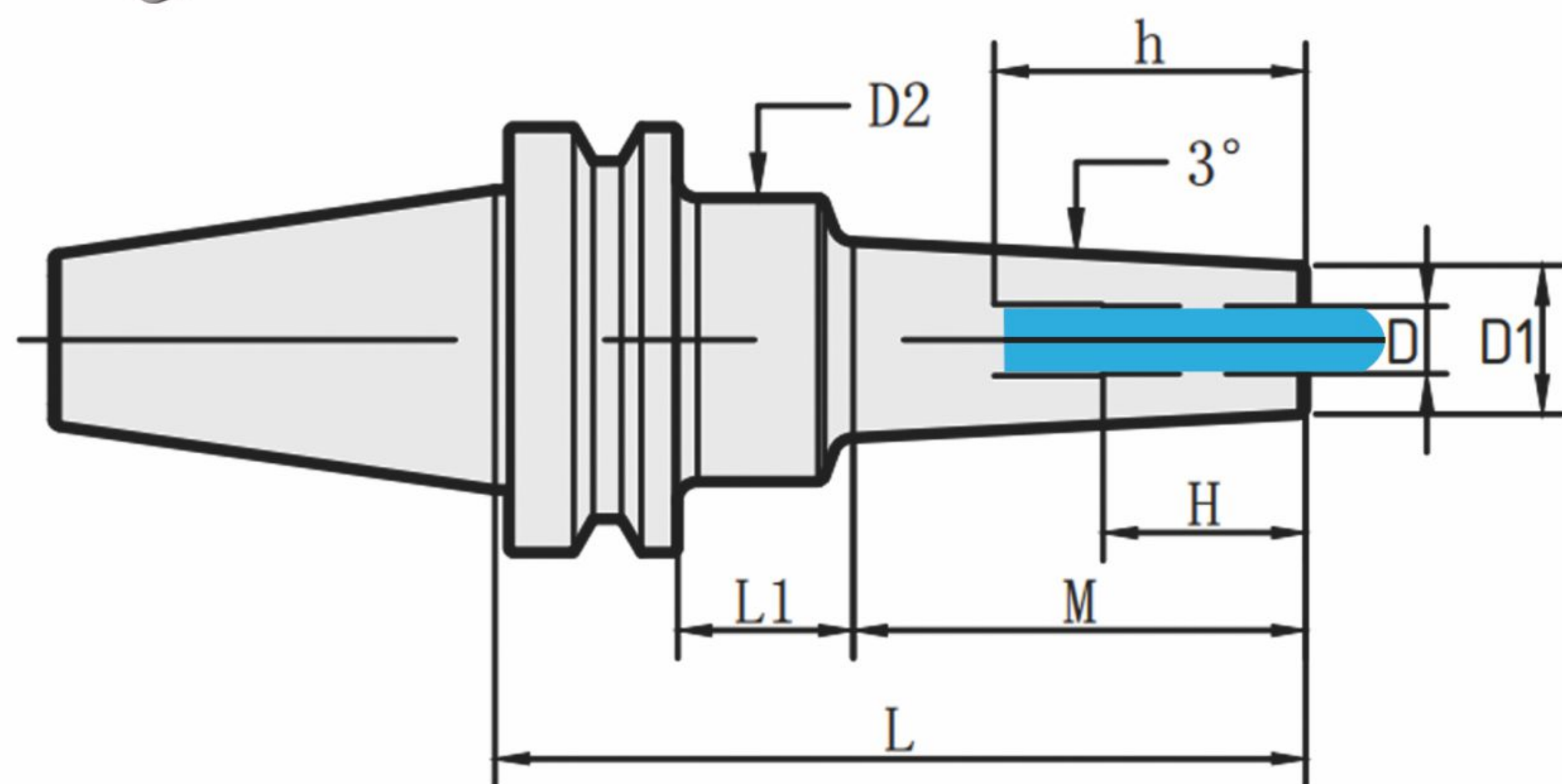
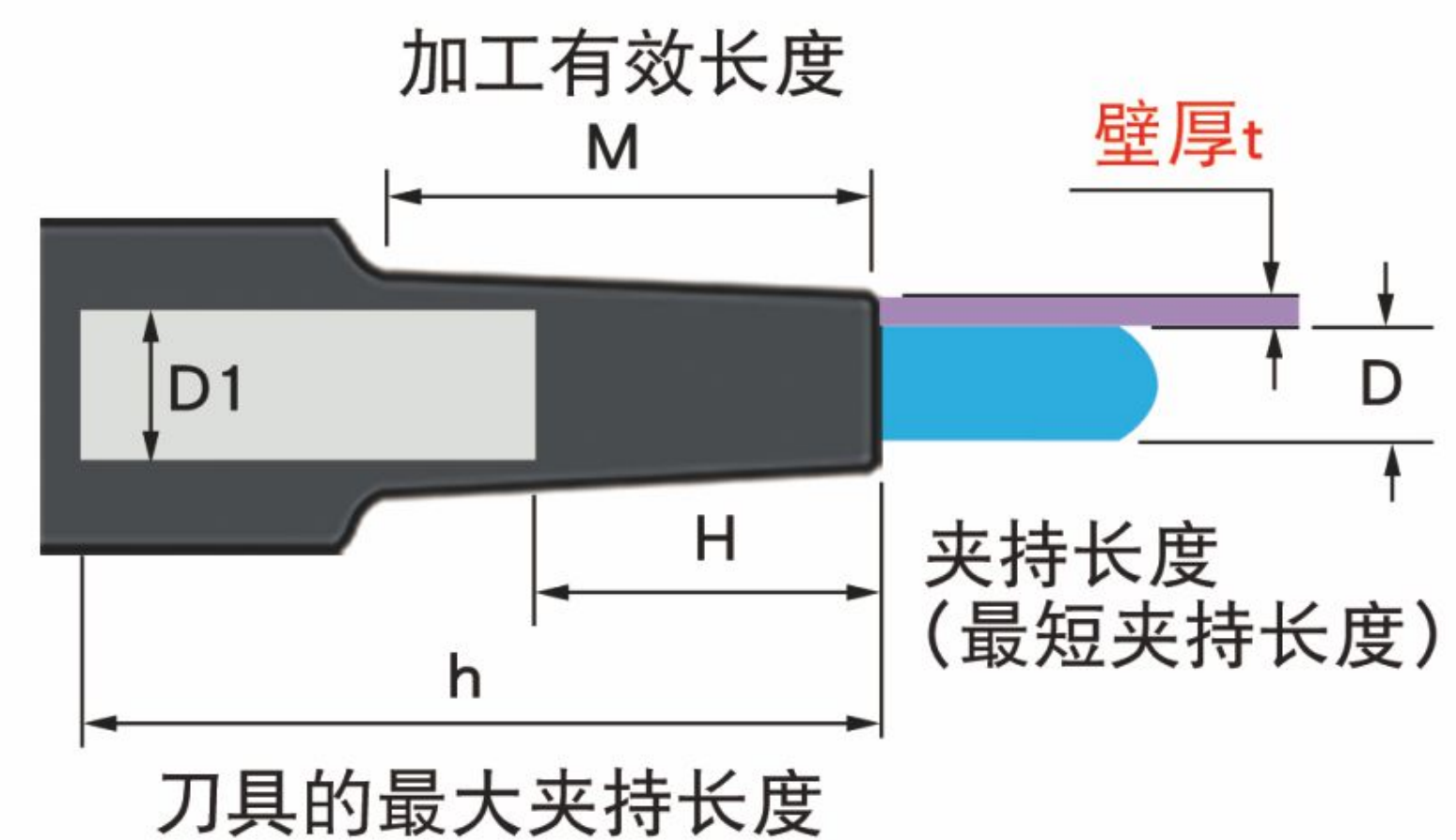
单位: mm

型号	图	D	D1	t	L	M	L1	L2	D2	D3	H	h	库存
BT40 SHSA4- 95-M 22	1	4	7	1.5	95	42	26	-	25	-	12	130	○
-120-M 67					120	67						155	○
-125-M 42					125	42	56		26			160	○
-150-M 67					150	67			25			185	○
-150-M 97						97	26		26				○
-155-M 42	2				155	42	33	53			40	190	○
-180-M 67					180	67						215	○
-180-M 97	1					97	56	-	25	-			○
-210-M 97	2				210	97	33	53			39	245	○
BT40 SHRA4- 75-M 22	1	4	10		3	75	22	26	-	25	-	12	110
- 95-M 42				95		42			26			130	●

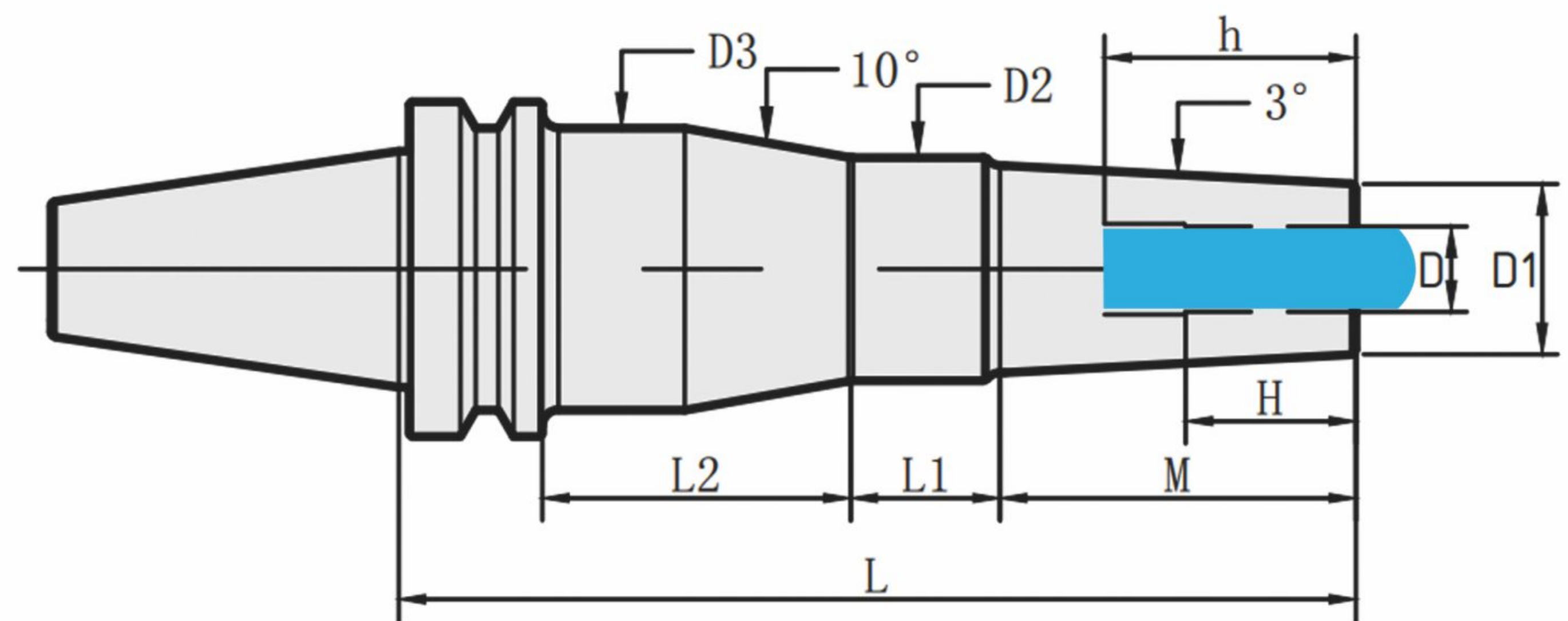
型号	图	D	D1	t	L	M	L1	L2	D2	D3	H	h	库存
BT40 SHRA4-105-M 22	1	4	10	3	105	22	56	-	26	-	12	140	
-120-M 67					120	67	26			25		155	●
-125-M 42					125	42	56			26		160	○
-135-M 22	2				135	22	33	53			40	170	
-150-M 67	1				150	67	56	-	25	-		185	●
-150-M 97						97	26						○
-155-M 42	2				155	42	33	53	26	40		190	○
-180-M 67					180	67			25	39		215	○
-180-M 97	1					97	56	-	26	-			●
-180-M127						127	26		36				○
-210-M 97	2			210	97	33	53	26	40		245		

BT40 整体式热胀刀柄(不锈钢材质)

型号	图	D	D1	t	L	M	L1	L2	D2	D3	H	h	库存	
BT40 SHRA4-210-M127	1	4	10	3	210	127	56	-	36	-	12	245	○	
-240-M127	2				240	127	28	58		50			275	
BT40 SHSA6-95-M42	1	6	9	1.5	95	42	26	-	25	-	18	130	○	
-120-M67					120	67				26			155	○
-125-M42					125	42	56			25			160	○
-150-M67					150	67							185	○
-150-M97						97	26			36				○
-155-M42	2				155	42	33	53	25	39			190	○
-180-M67					180	67			26	40			215	○
-180-M97	1					97	56	-	36	-				○
-210-M97	2				210	97	28	58		50			245	○
BT40 SHSB6-95-M42	1	6	10		2	95	42	26	-	25	-	18	130	○
-120-M67				120		67							155	●
-125-M42				95		42	26	-	25	-			160	○
-150-M67				150		67							185	●
-150-M97						97	26			32				○
-155-M42	2			155		42	33	53	26	40			190	○
-180-M67				180		67			25	39			215	
-180-M97	1					97	56	-	36	-				●
-180-M127						127	26							○
-210-M97	2			210		97	28	58		50			245	
-210-M127	1					127	56	-		-				
-210-M157						157	26							
-240-M127	2			240		127	28	58		50			275	
-240-M157	1					157	56	-		-				
-270-M157	2			270	157	28	58		50			305		
BT40 SHRB6-75-M22	1	6	14	4	75	22	26	-	32	-	18	110	○	
-95-M42					95	42							130	●
-105-M22					105	22	56			36			140	
-120-M67					120	67	26			32			155	●
-125-M42					125	42	56						160	○
-135-M22	2				135	22	28	58	36	50			170	
-150-M67	1				150	67	56	-	32	-			185	●
-155-M42	2				155	42	28	58	36	50			190	○
-180-M67					180	67							215	●
BT40 SHSA8-95-M42	1	8	11		1.5	95	42	26	-	25	-	24	130	
-120-M67				120		67				36			155	○

型号	图	D	D1	t	L	M	L1	L2	D2	D3	H	h	库存	
BT40 SHSA8-125-M42	1	8	11	1.5	125	42	56	-	36	-	24	160		
-150-M67					150	67							185	○
-150-M97						97	26							○
-155-M42	2				155	42	33	53	25	39			190	
-180-M67					180	67	28	58	36	50			215	
-180-M97	1					97	56	-		-				○
-210-M97	2				210	97	28	58		50			245	○
BT40 SHSB8-95-M42	1	8	13		2.5	95	42	26	-	32	-	24	130	○
-120-M67				120		67							155	●
-125-M42				125		42	56			36			160	
-150-M67				150		67							185	●
-150-M97						97	26			32				○
-155-M42	2			155		42	30	56		46			190	
-180-M67				180		67	28	58	36	50	24	215		
-180-M97	1					97	56	-		-				●
-180-M127						127	26							○
-210-M97	2			210		97	28	58		50			245	
-210-M127	1				127	56	-		-					
-210-M157					157	26								
-240-M127	2			240	127	28	58		50			275		
-240-M157	1				157	56	-		-					
-270-M157	2			270	157	28	58	42	53			305		
BT40 SHRB8-75-M22	1	8	18	5	75	22	26	-	32	-	24	110	○	
-95-M42					95	42				36			130	●
-105-M22					105	22	56						140	
-120-M67					120	67	26						155	●
-125-M42					125	42	56						160	○
-135-M22	2				135	22	30	56	32	46			170	
-150-M67	1				150	67	56	-	36	-			185	●
-155-M42	2			155	42	30	56	32	46			190	○	
-180-M67				180	67	28	58	36	50			215	○	
BT40 SHSA10-95-M42	1	10	13	1.5	95	42	26	-	25	-	30	130		
-120-M67					120	67				36			155	○
-125-M42					125	42	56						160	○
-150-M67					150	67							185	○
-150-M97						97	26							○
-155-M42	2			155	42	28	58		50			190	○	

BT40 整体式热胀刀柄(不锈钢材质)

型号	图	D	D1	t	L	M	L1	L2	D2	D3	H	h	库存	
BT40 SHSA10-180-M 67	2	10	13	1.5	180	67	28	58	-	50	30	215	○	
-180-M 97	1					97	56	-		-			○	
-210-M 97	2					210	97	28	58		50		245	
BT40 SHSB10- 95-M 42	1	10	16	3	95	42	26	-	32	-	30	130	○	
-120-M 67						120	67			36			155	●
-125-M 42						125	42	56					160	
-150-M 67						150	67			32			185	●
-150-M 97							97	26						○
-155-M 42	2					155	42	28	58	36	50		190	
-180-M 67						180	67						215	
-180-M 97	1						97	56	-		-			●
-180-M127							127	26		50			190	○
-210-M 97	2					210	97	28	58	36	50		245	
-210-M127	1						127	56	-	50	-		220	
-210-M157							157	26						
-240-M127						240	127	86					250	
-240-M157							157	56						
-270-M157						270	157	86					305	
BT40 SHRB10- 75-M 22	1	10	22	6	75	22	26	-	32	-	30	110	○	
- 95-M 42						95	42						130	●
-105-M 22						105	22	56					140	
-120-M 67						120	67	26		36			155	●
-125-M 42						125	42	56					160	○
-135-M 22	2					135	22	28	58		50		170	
-150-M 67	1					150	67	56	-		-		185	●
-155-M 42	2					155	42	28	58		50		190	○
-180-M 67						180	67						215	○
BT40 SHSA12- 95-M 42	1	12	15	1.5	95	42	26	-	32	-	30	130		
-120-M 67						120	67						155	●
-125-M 42						125	42	56		36			160	
-150-M 67						150	67						185	●
-150-M 97							97	26						○
-155-M 42	2					155	42	28	58		50		190	
-180-M 67						180	67	30	56	32	46		215	
-180-M 97	1						97	56	-	36	-			●
-210-M 97	2					210	97	28	58		50		245	
BT40 SHSB12- 95-M 42	1	12	19		3.5	95	42	26	-	32	-	30	130	○

型号	图	D	D1	t	L	M	L1	L2	D2	D3	H	h	库存	
BT40 SHSB12-120-M 67	1	12	19	3.5	120	67	26	-	36	-	30	155	●	
-125-M 42						125	42	56					160	
-150-M 67						150	67						185	●
-150-M 97							97	26		50			160	○
-155-M 42	2					155	42	28	58	36	50		190	
-180-M 67						180	67						215	
-180-M 97	1						97	56	-	50	-		190	●
-180-M127							127	26						○
-210-M 97						210	97	86					220	
-210-M127							127	56						
-210-M157							157	26						
-240-M127						240	127	86					250	
-240-M157							157	56						
-270-M157						280	157	86					280	
BT40 SHRB12- 75-M 22	1	12	26		7	75	22	26	-	42	-	30	85	○
- 95-M 42						95	42			50			105	●
-105-M 22						105	22	56					115	
-120-M 67						120	67	26					130	●
-125-M 42						125	42	56					135	○
-135-M 22						135	22	86					145	
-150-M 67						150	67	56					160	●
-155-M 42						155	42	86					165	○
-180-M 67					180	67						190	○	
BT40 SHSB16- 95-M 42	1	16	24	4	95	42	26	-	42	-	32	105	○	
-120-M 67						120	67						130	●
-125-M 42						125	42	56		50			135	
-150-M 67						150	67			42			160	●
-150-M 97							97	26		50				○
-155-M 42						155	42	86					165	
-180-M 67						180	67						190	
-180-M 97							97	56						●
-180-M127							127	26						○
-210-M 97						210	97	86					220	
-210-M127							127	56						
-210-M157							157	26						
-240-M127					240	127	86		53			250		
-240-M157						157	56		50					

BT40 整体式热胀刀柄(不锈钢材质)

型号	图	D	D1	t	L	M	L1	L2	D2	D3	H	h	库存				
BT40 SHSB16-270-M157	1	16	24	4	270	157	86	-	50	-	32	280					
BT40 SHRB16- 75-M 22	1	16	32	8	75	22	26	-	50	-	32	85	○				
- 95-M 42					95	42			42			105	●				
-105-M 22					105	22	56		50			115					
-120-M 67					120	67	26					130	●				
-125-M 42					125	42	56					135	○				
-135-M 22					135	22	86					145					
-150-M 67					150	67	56					160	●				
-155-M 42					155	42	86					165	○				
-180-M 67					180	67						190	○				
-210-M 97					210	97						220					
BT40 SHSB20- 95-M 42					1	20	29	4.5	95	42	26	-	42	-	40	105	○
-120-M 67									120	67			50			130	●
-125-M 42									125	42	56					135	
-150-M 67	150	67										160	●				
-150-M 97		97	26										160	○			
-155-M 42	2	155	42	28					58	42	53		165				
-180-M 67	1	180	67	86					-	50	-		190				
-180-M 97		97	56										190	●			
-180-M127		127	26											190	○		
-210-M 97		210	97	86									220				
-210-M127		127	56											220			
-210-M157		157	26											220			
-240-M127	240	127	86									250					
-240-M157		157	56						250								
-270-M157	270	157	86					280									
BT40 SHRB20- 95-M 42	1	20	38	9	95	42	26	-	50	-	40	105	●				
-120-M 67					120	67						130	●				
-125-M 42					125	42	56					135	○				
-150-M 67					150	67						160	●				
-155-M 42					155	42	86					165	○				
-180-M 67					180	67						190	○				
BT40 SHRB25- 95-M 42	1	25	45	10	95	42	26	-	50	-	45	105	●				
-125-M 42					125		56					130	○				
-155-M 42					155		86					165	○				
-180-M 67					180	67						190	○				

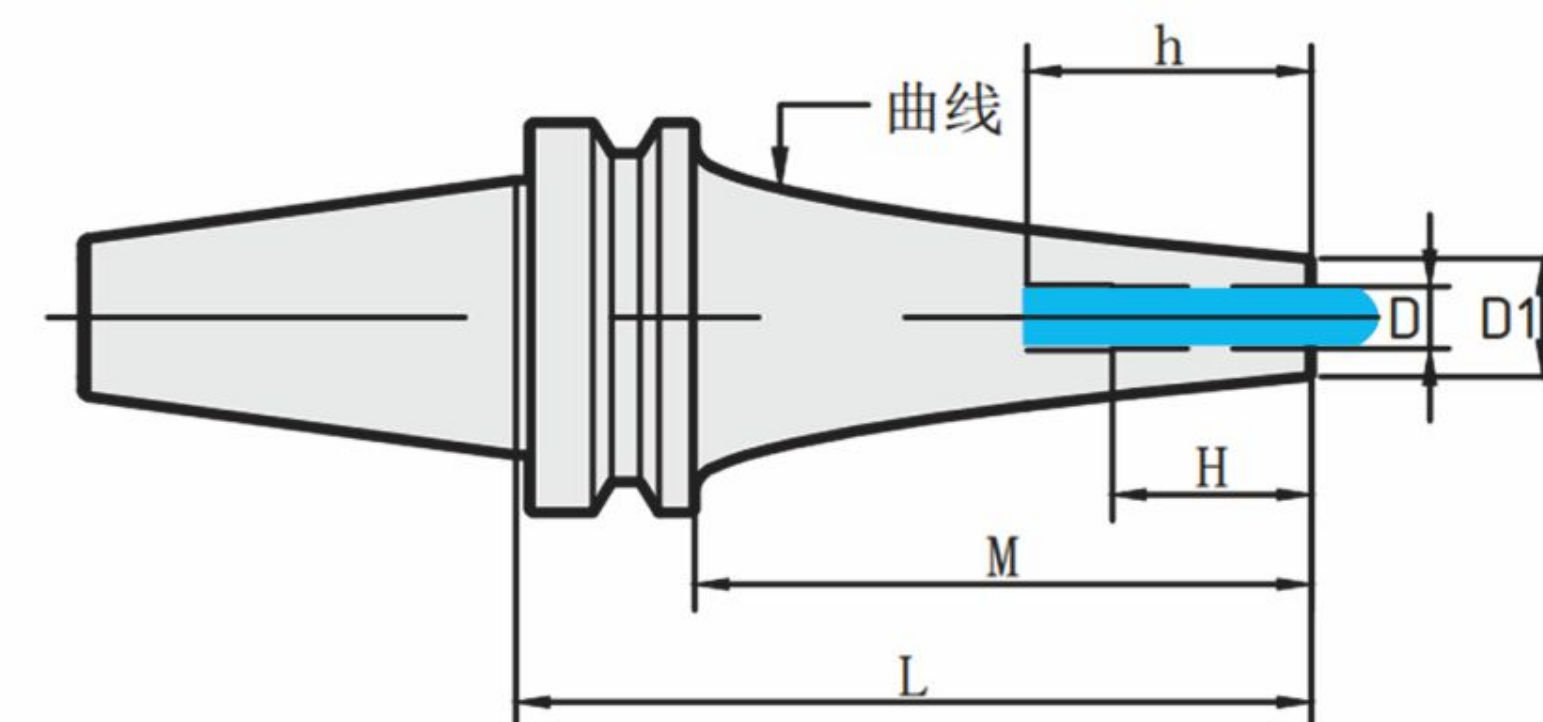
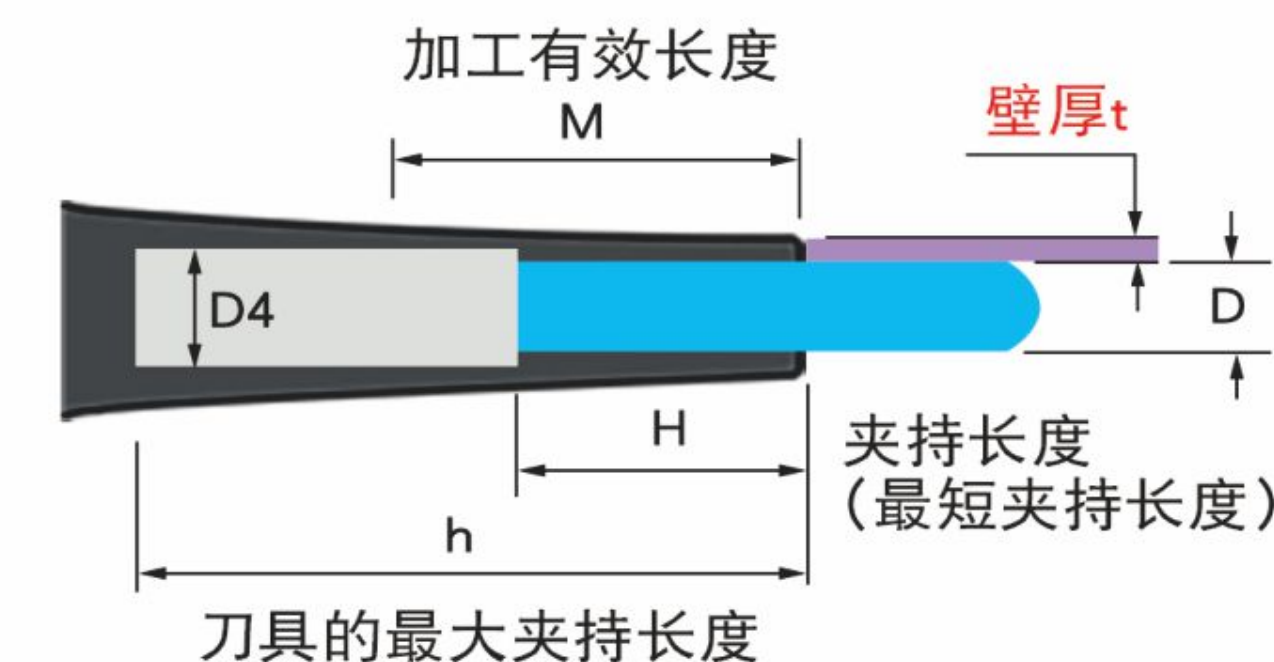

型号	D	D1	t	L	M	C1	D4	D2	D3	H	h	库存
BT40 SHSA4- 90 CV	4	7	1.5	90	64	53	5	-	-	13	125	●
-120 CV				120	94						155	●
-150 CV				150	124						185	●
-180 CV				180	154						215	●
-210 CV				210	184						245	●
-240 CV				240	214						217	
BT40 SHRA4-120 CV	4	10	3	120	94	53	5	-	-	18	155	●
-150 CV				150	124						185	●
-180 CV				180	154						215	●
-210 CV				210	184						245	●
BT40 SHSA6- 90 CV	6	9	1.5	90	64	53	7	-	-	19	125	●
-120 CV				120	94						155	●
-150 CV				150	124						185	●
-180 CV				180	154						215	●
-210 CV				210	184						245	●
-240 CV				240	214						275	
BT40 SHRA6- 90 CV	6	13	1.5	90	64	53	7	-	-	19	125	●
-120 CV				120	94						155	●

BT40 整体式热胀刀柄(不锈钢材质)

型号	D	D1	t	L	M	C1	D4	D2	D3	H	h	库存
BT40 SHRA6-150 CV	6	13	3.5	150	124	53	7	-	-	19	185	●
-180 CV				180	154						215	●
-210 CV				210	184						245	●
BT40 SHSA8- 90 CV	8	11	1.5	90	64	53	9	-	-	24	125	●
-120 CV				120	94						155	●
-150 CV				150	124						185	●
-180 CV				180	154						215	●
-210 CV				210	184						245	●
-240 CV				240	214						275	●
BT40 SHRA8- 90 CV	8	16	4	90	64	53	9	-	-	25	125	●
-120 CV				120	94						155	●
-150 CV				150	124						185	●
-180 CV				180	154						215	●
-210 CV				210	184						245	●
BT40 SHSA10- 90 CV	10	13	1.5	90	64	53	11	-	-	30	125	●
-120 CV				120	94						155	●
-150 CV				150	124						185	●
-180 CV				180	154						215	●
BT40 SHSA10-210 CV				210	184	53	11	-	-	30	245	●
-240 CV				240	214						275	●
BT40 SHRA10 - 90 CV	10	19	4.5	90	64	53	11	-	-	30	125	●
-120 CV				120	94						155	●
-150 CV				150	124						185	●
-180 CV				180	154						215	●
-210 CV				210	184						245	●
BT40 SHSA12 - 90 CV	12	15	1.5	90	64	53	14	-	-	30	125	●
-120 CV				120	94		13				155	●
-150 CV				150	124		185				●	
-180 CV				180	154		215				●	
-210 CV				210	184		245				●	
-240 CV				240	214		275				●	
BT40 SHRA12 - 90 CV	12	22	5	90	64	53	14	-	-	30	125	●
-120 CV				120	94		13				155	●
-150 CV				150	124		185				●	
-180 CV				180	154		215				●	
-210 CV				210	184		245				●	

型号	D	D1	t	L	M	C1	D4	D2	D3	H	h	库存
BT40 SHSB16 - 90 CV	16	21	2.5	90	64	53	17	-	-	32	100	●
-120 CV				120	94						130	●
-150 CV				150	124						160	●
-180 CV				180	154						190	●
-210 CV				210	184						220	●
-240 CV				240	214						250	●
BT40 SHSB20 - 90 CV	20	26	3	90	64	50.5	21	-	-	40	100	●
-120 CV				120	94	53					130	●
-150 CV				150	124	160					●	
-180 CV				180	154	190					●	
-210 CV				210	184	220					●	
-240 CV				240	214	250					●	

BT40 整体式热胀刀柄(不锈钢材质)



图1



图2

● 为常备库存 ○ 为少量库存

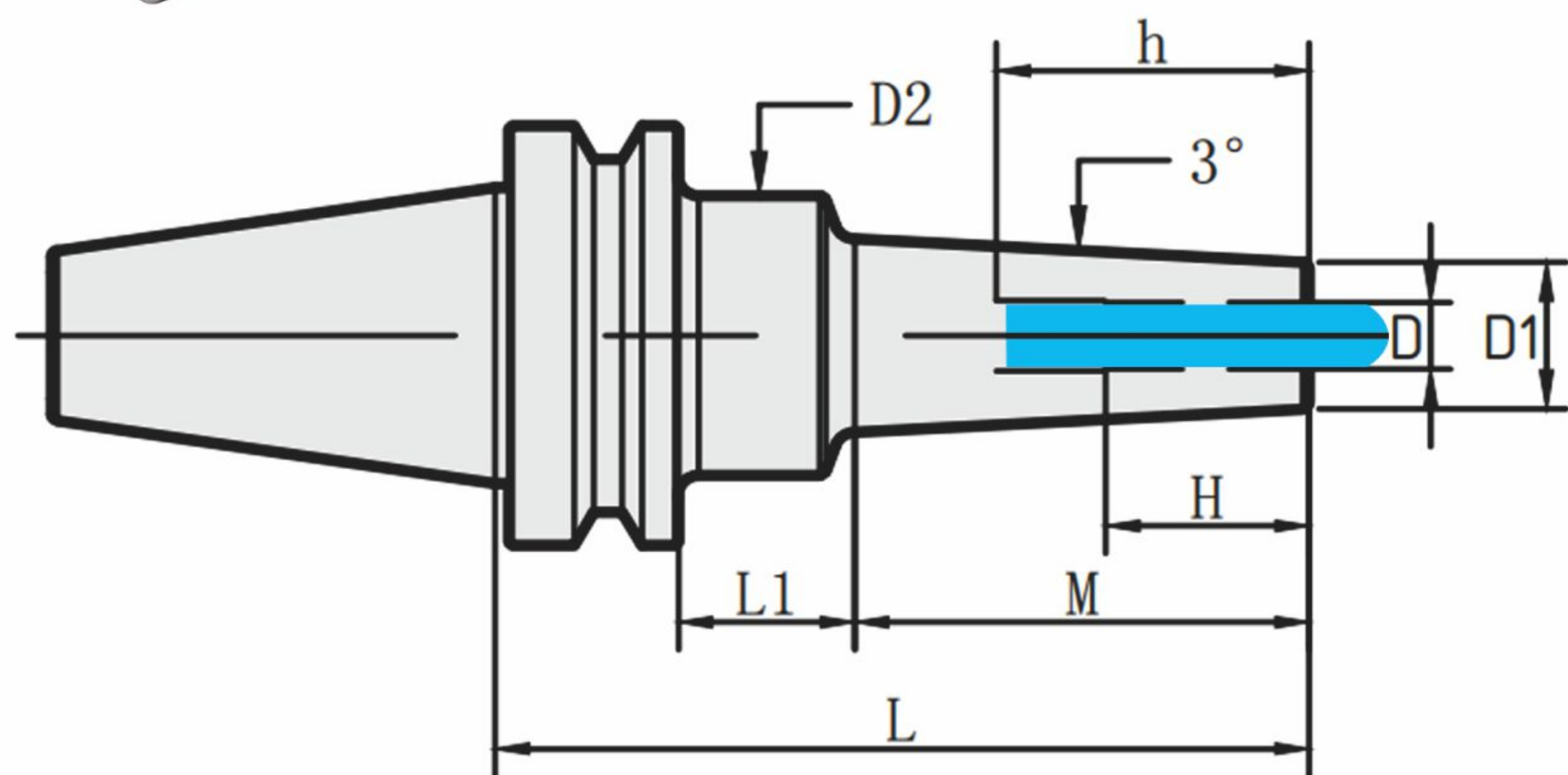
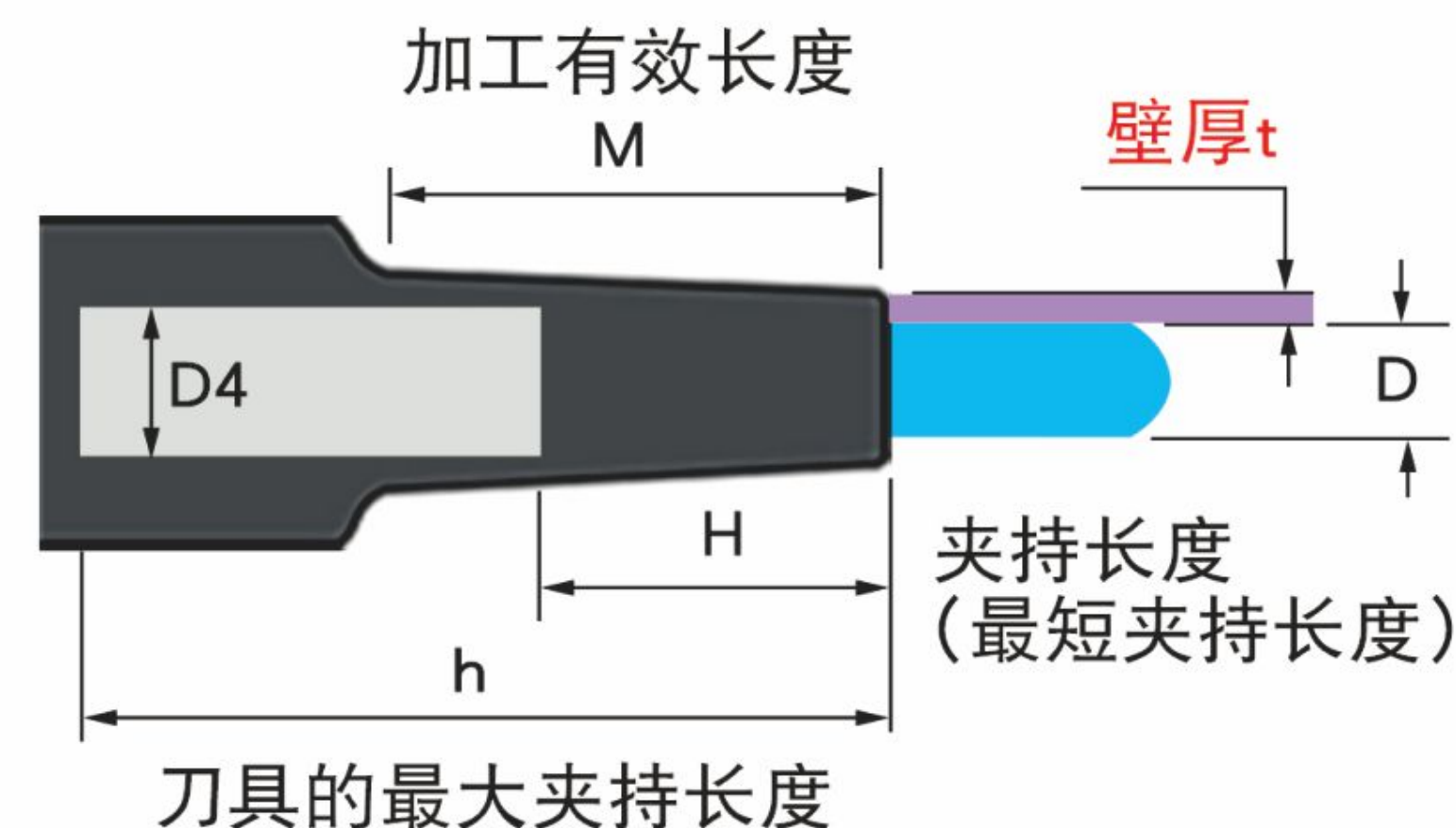
单位: mm

型号	图	D	D1	t	L	M	L1	L2	D2	D3	H	h	库存			
BT40 SHSA4- 95-M 22	1	4	7	1.5	95	42	26	-	25	-	12	130	○			
-120-M 67					120	67							155	○		
-125-M 42					125	42	56		26				160	○		
-150-M 67					150	67		25					185	○		
-150-M 97						97	26		26						○	
-155-M 42					2		155	42	33	53		40			190	○
-180-M 67							180	67						215	○	
-180-M 97						1		97	56	-	25	-				○
-210-M 97					2		210	97	33	53		39			245	○
BT40 SHRA4- 75-M 22	1	4	10	3	75	22	26	-	25	-	12	110	○			
- 95-M 42					95	42		26					130	●		

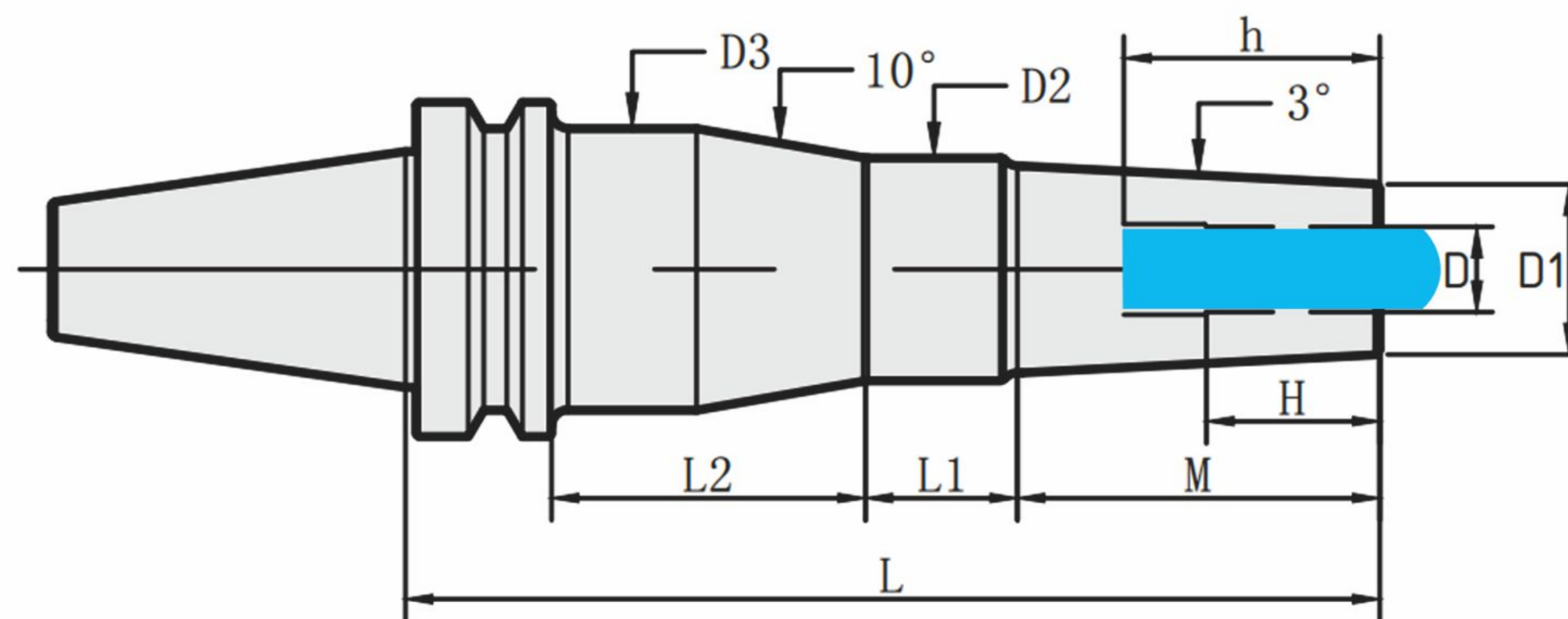
型号	图	D	D1	t	L	M	L1	L2	D2	D3	H	h	库存		
BT40 SHRA4-105-M 22	1	4	10	3	105	22	56	-	26	-	12	140			
-120-M 67					120	67	26		25				155	●	
-125-M 42					125	42	56		26				160	○	
-135-M 22					2	135	22	33	53		40			170	
-150-M 67					1	150	67	56	-	25	-			185	●
-150-M 97							97	26							○
-155-M 42					2	155	42	33	53	26	40			190	○
-180-M 67							180	67		25	39			215	○
-180-M 97					1		97	56	-	26	-				●
-180-M127							127	26		36					○
-210-M 97	2	210	97	33	53	26	40			245					

BT40 整体式热胀刀柄(不锈钢材质)

型号	图	D	D1	t	L	M	L1	L2	D2	D3	H	h	库存		
BT40 SHRA4-210-M127	1	4	10	3	210	127	56	-	36	-	12	245	o		
-240-M127	2				240	127	28	58		50					
BT40 SHSA6-95-M42	1	6	9	1.5	95	42	26	-	25	-	18	130	o		
-120-M67					120	67						26		155	o
-125-M42					125	42	56					25		160	o
-150-M67					150	67								185	o
-150-M97					97	26			36						o
-155-M42	2				155	42	33	53	25	39				190	o
-180-M67					180	67			26	40				215	o
-180-M97	1				97	56	-	36	-						o
-210-M97	2				210	97	28	58		50				245	o
BT40 SHSB6-95-M42	1				6	10	2	95	42	26		-	25	-	18
-120-M67		120	67										155	●	
-125-M42		95	42	26				-	25	-			160	o	
-150-M67		150	67										185	●	
-150-M97		97	26						32					o	
-155-M42	2	155	42	33				53	26	40			190	o	
-180-M67		180	67						25	39			215		
-180-M97	1	97	56	-				36	-					●	
-180-M127		127	26											o	
-210-M97	2	210	97	28				58		50			245		
-210-M127	1	127	56	-											
-210-M157		157	26												
-240-M127	2	240	127	28				58		50			275		
-240-M157	1	157	56	-											
-270-M157	2	270	157	28	58		50			305					
BT40 SHRB6-75-M22	1	6	14	4	75	22	26	-	32	-	18	110	o		
-95-M42					95	42								130	●
-105-M22					105	22	56		36					140	
-120-M67					120	67	26		32					155	●
-125-M42					125	42	56							160	o
-135-M22	2				135	22	28	58	36	50				170	
-150-M67	1				150	67	56	-	32	-				185	●
-155-M42	2				155	42	28	58	36	50				190	o
-180-M67					180	67								215	●
BT40 SHSA8-95-M42	1				8	11	1.5	95	42	26		-	25	-	24
-120-M67		120	67								36		155	o	

型号	图	D	D1	t	L	M	L1	L2	D2	D3	H	h	库存		
BT40 SHSA8-125-M42	1	8	11	1.5	125	42	56	-	36	-	24	160			
-150-M67					150	67								185	o
-150-M97					97	26									o
-155-M42	2				155	42	33	53	25	39				190	
-180-M67					180	67	28	58	36	50				215	
-180-M97	1				97	56	-		-						o
-210-M97	2				210	97	28	58		50				245	o
BT40 SHSB8-95-M42	1				8	13	2.5	95	42	26		-	32	-	24
-120-M67		120	67								36		155	●	
-125-M42		125	42	56									160		
-150-M67		150	67										185	●	
-150-M97		97	26						32					o	
-155-M42	2	155	42	30				56		46			190		
-180-M67		180	67	28				58	36	50	24	215			
-180-M97	1	97	56	-					-					●	
-180-M127		127	26											o	
-210-M97	2	210	97	28				58		50			245		
-210-M127	1	127	56	-					-						
-210-M157		157	26												
-240-M127	2	240	127	28	58		50			275					
-240-M157	1	157	56	-		-									
-270-M157	2	270	157	28	58	42	53			305					
BT40 SHRB8-75-M22	1	8	18	5	75	22	26	-	32	-	24	110	o		
-95-M42					95	42						36		130	●
-105-M22					105	22	56							140	
-120-M67					120	67	26							155	●
-125-M42					125	42	56							160	o
-135-M22	2				135	22	30	56	32	46				170	
-150-M67	1				150	67	56	-	36	-				185	●
-155-M42	2				155	42	30	56	32	46				190	o
-180-M67		180	67	28	58	36	50			215	o				
BT40 SHSA10-95-M42	1	10	13	1.5	95	42	26	-	25	-	30	130			
-120-M67					120	67						36		155	o
-125-M42					125	42	56							160	o
-150-M67					150	67								185	o
-150-M97					97	26									o
-155-M42	2				155	42	28	58		50				190	o

BT40 整体式热胀刀柄(不锈钢材质)

型号	图	D	D1	t	L	M	L1	L2	D2	D3	H	h	库存	
BT40 SHSA10-180-M 67	2	10	13	1.5	180	67	28	58	-	50	30	215	○	
-180-M 97	1					97	56	-		-			○	
-210-M 97	2					210	97	28	58		50		245	
BT40 SHSB10-95-M 42	1	10	16	3	95	42	26	-	32	-	30	130	○	
-120-M 67						120	67			36			155	●
-125-M 42						125	42	56					160	
-150-M 67						150	67			32			185	●
-150-M 97							97	26						○
-155-M 42	2					155	42	28	58	36	50		190	
-180-M 67						180	67						215	
-180-M 97	1						97	56	-		-			●
-180-M127							127	26		50			190	○
-210-M 97	2					210	97	28	58	36	50		245	
-210-M127	1						127	56	-	50	-		220	
-210-M157							157	26						
-240-M127						240	127	86					250	
-240-M157							157	56						
-270-M157						270	157	86					305	
BT40 SHRB10-75-M 22	1	10	22	6	75	22	26	-	32	-	30	110	○	
-95-M 42						95	42						130	●
-105-M 22						105	22	56					140	
-120-M 67						120	67	26		36			155	●
-125-M 42						125	42	56					160	○
-135-M 22	2					135	22	28	58		50		170	
-150-M 67	1					150	67	56	-		-		185	●
-155-M 42	2					155	42	28	58		50		190	○
-180-M 67						180	67						215	○
BT40 SHSA12-95-M 42	1	12	15	1.5	95	42	26	-	32	-	30	130		
-120-M 67						120	67						155	●
-125-M 42						125	42	56		36			160	
-150-M 67						150	67						185	●
-150-M 97							97	26						○
-155-M 42	2					155	42	28	58		50		190	
-180-M 67						180	67	30	56	32	46		215	
-180-M 97	1						97	56	-	36	-			●
-210-M 97	2					210	97	28	58		50		245	
BT40 SHSB12-95-M 42	1	12	19	3.5	95	42	26	-	32	-	30	130	○	

型号	图	D	D1	t	L	M	L1	L2	D2	D3	H	h	库存	
BT40 SHSB12-120-M 67	1	12	19	3.5	120	67	26	-	36	-	30	155	●	
-125-M 42						125	42	56					160	
-150-M 67						150	67						185	●
-150-M 97							97	26		50			160	○
-155-M 42	2					155	42	28	58	36	50		190	
-180-M 67						180	67						215	
-180-M 97	1						97	56	-	50	-		190	●
-180-M127							127	26						○
-210-M 97						210	97	86					220	
-210-M127							127	56						
-210-M157							157	26						
-240-M127						240	127	86					250	
-240-M157							157	56						
-270-M157						280	157	86					280	
BT40 SHRB12-75-M 22	1	12	26		7	75	22	26	-	42	-	30	85	○
-95-M 42						95	42			50			105	●
-105-M 22						105	22	56					115	
-120-M 67						120	67	26					130	●
-125-M 42						125	42	56					135	○
-135-M 22						135	22	86					145	
-150-M 67						150	67	56					160	●
-155-M 42						155	42	86					165	○
-180-M 67						180	67						190	○
BT40 SHSB16-95-M 42	1	16	24	4	95	42	26	-	42	-	32	105	○	
-120-M 67						120	67						130	●
-125-M 42						125	42	56		50			135	
-150-M 67						150	67			42			160	●
-150-M 97							97	26		50				○
-155-M 42						155	42	86					165	
-180-M 67						180	67						190	
-180-M 97							97	56						●
-180-M127							127	26						○
-210-M 97						210	97	86					220	
-210-M127							127	56						
-210-M157							157	26						
-240-M127						240	127	86		53			250	
-240-M157							157	56		50				

BT40 整体式热胀刀柄(不锈钢材质)

型号	图	D	D1	t	L	M	L1	L2	D2	D3	H	h	库存	
BT40 SHSB16-270-M157	1	16	24	4	270	157	86	-	50	-	32	280		
BT40 SHRB16- 75-M 22	1	16	32	8	75	22	26	-	50	-	32	85	○	
- 95-M 42					95	42				42			105	●
-105-M 22					105	22	56			50			115	
-120-M 67					120	67	26						130	●
-125-M 42					125	42	56						135	○
-135-M 22					135	22	86						145	
-150-M 67					150	67	56						160	●
-155-M 42					155	42	86						165	○
-180-M 67					180	67							190	○
-210-M 97					210	97							220	
BT40 SHSB20- 95-M 42	1	20	29		4.5	95	42	26	-	42	-	40	105	○
-120-M 67				120		67							130	●
-125-M 42				125		42	56			50			135	
-150-M 67				150		67							160	●
-150-M 97						97	26							○
-155-M 42	2			155		42	28	58	42	53			165	
-180-M 67	1			180		67	86	-	50	-			190	
-180-M 97						97	56							●
-180-M127						127	26							○
-210-M 97				210		97	86						220	
-210-M127						127	56							
-210-M157						157	26							
-240-M127				240		127	86						250	
-240-M157						157	56							
-270-M157				270		157	86						280	
BT40 SHRB20- 95-M 42	1	20	38	9		95	42	26	-	50	-	40	105	●
-120-M 67						120	67							130
-125-M 42					125	42	56						135	○
-150-M 67					150	67							160	●
-155-M 42					155	42	86						165	○
-180-M 67					180	67							190	○
BT40 SHRB25- 95-M 42	1	25	45		10	95	42	26	-	50	-	45	105	●
-125-M 42				125			56						130	○
-155-M 42				155			86						165	○
-180-M 67				180		67							190	○

BT40 整体式热胀刀柄(不锈钢材质)

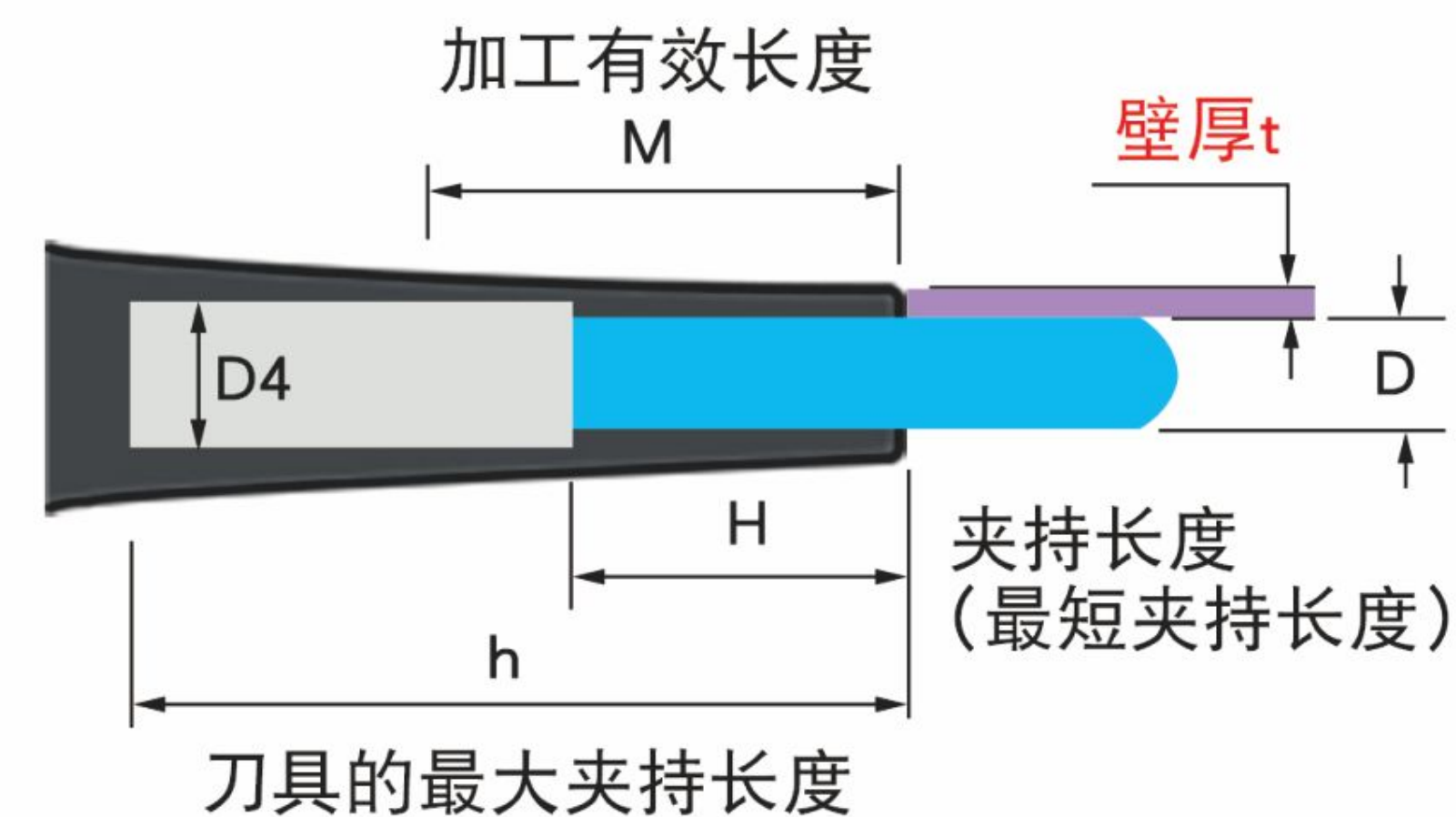
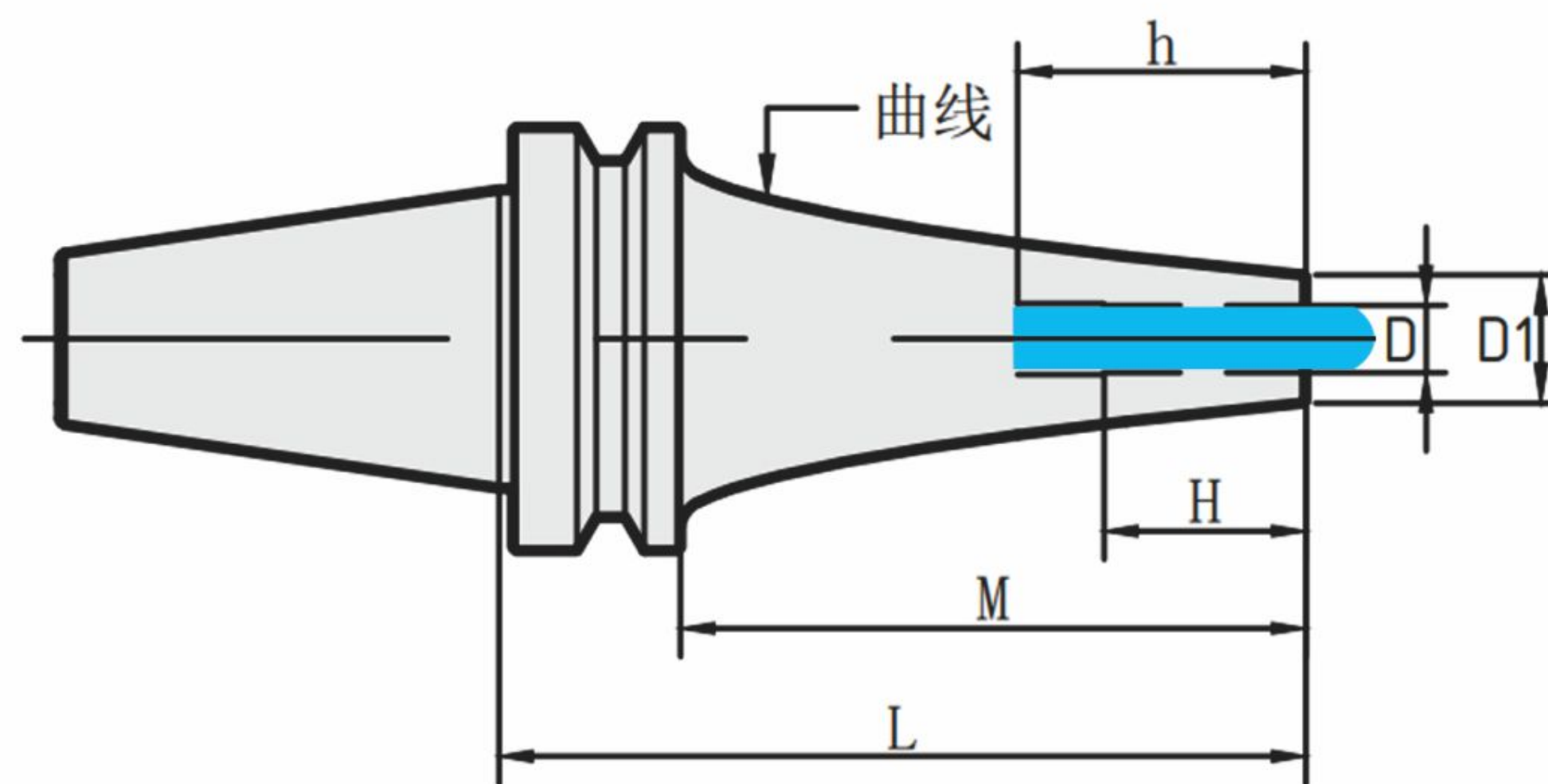

● 为常备库存 ○ 为少量库存

单位: mm

型号	D	D1	t	L	M	C1	D4	D2	D3	H	h	库存
BT40 SHSA4- 90 CV	4	7	1.5	90	64	53	5	-	-	13	125	●
-120 CV				120	94						155	●
-150 CV				150	124						185	●
-180 CV				180	154						215	●
-210 CV				210	184						245	●
-240 CV				240	214						217	
BT40 SHRA4-120 CV				4	10						3	120
-150 CV	150	124	185			●						
-180 CV	180	154	215			●						
-210 CV	210	184	245			●						
BT40 SHSA6- 90 CV	6	9	1.5	90	64	53	7	-	-	19	125	●
-120 CV				120	94						155	●
-150 CV				150	124						185	●
-180 CV				180	154						215	●
-210 CV				210	184						245	●
-240 CV				240	214						275	
BT40 SHRA6- 90 CV	6	13	1.5	90	64	53	7	-	-	19	125	●
-120 CV				120	94						155	●

型号	D	D1	t	L	M	C1	D4	D2	D3	H	h	库存
BT40 SHRA6-150 CV	6	13	3.5	150	124	53	7	-	-	19	185	●
-180 CV				180	154						215	●
-210 CV				210	184						245	●
BT40 SHSA8- 90 CV	8	11	1.5	90	64	53	9	-	-	24	125	●
-120 CV				120	94						155	●
-150 CV				150	124						185	●
-180 CV				180	154						215	●
-240 CV				240	214						275	
BT40 SHRA8- 90 CV	8	16	4	90	64	53	9	-	-	25	125	●
-120 CV				120	94						155	●
-150 CV				150	124						185	●
-180 CV				180	154						215	●
-210 CV				210	184						245	●
BT40 SHSA10- 90 CV	10	13	1.5	90	64	53	11	-	-	30	125	●
-120 CV				120	94						155	●
-150 CV				150	124						185	●
-180 CV	180	154	215	●								

BT40 整体式热胀刀柄(不锈钢材质)

型号	D	D1	t	L	M	C1	D4	D2	D3	H	h	库存
BT40 SHSA10-210 CV	10	13	1.5	210	184	53	11	-	-	30	245	●
-240 CV				240	214						275	
BT40 SHRA10 - 90 CV	10	19	4.5	90	64	53	11	-	-	30	125	●
-120 CV				120	94						155	●
-150 CV				150	124						185	●
-180 CV				180	154						215	●
-210 CV				210	184						245	●
BT40 SHSA12 - 90 CV	12	15	1.5	90	64	53	14	-	-	30	125	●
-120 CV				120	94		13				155	●
-150 CV				150	124		185				●	
-180 CV				180	154		215				●	
-210 CV				210	184		245				●	
-240 CV				240	214		275					
BT40 SHRA12 - 90 CV	12	22	5	90	64	53	14	-	-	30	125	●
-120 CV				120	94		13				155	●
-150 CV				150	124		185				●	
-180 CV				180	154		215				●	
-210 CV				210	184		245				●	
BT40 SHSB16 - 90 CV	16	21	2.5	90	64	53	17	-	-	32	100	●
-120 CV				120	94						130	●
-150 CV				150	124						160	●
-180 CV				180	154						190	●
-210 CV				210	184						220	●
-240 CV				240	214						250	
BT40 SHSB20 - 90 CV	20	26	3	90	64	50.5	21	-	-	40	100	●
-120 CV				120	94	53					130	●
-150 CV				150	124	160					●	
-180 CV				180	154	190					●	
-210 CV				210	184	220					●	
-240 CV				240	214	250						

BT50 整体式热胀刀柄(不锈钢材质)



图1



图2

● 为常备库存 ○ 为少量库存

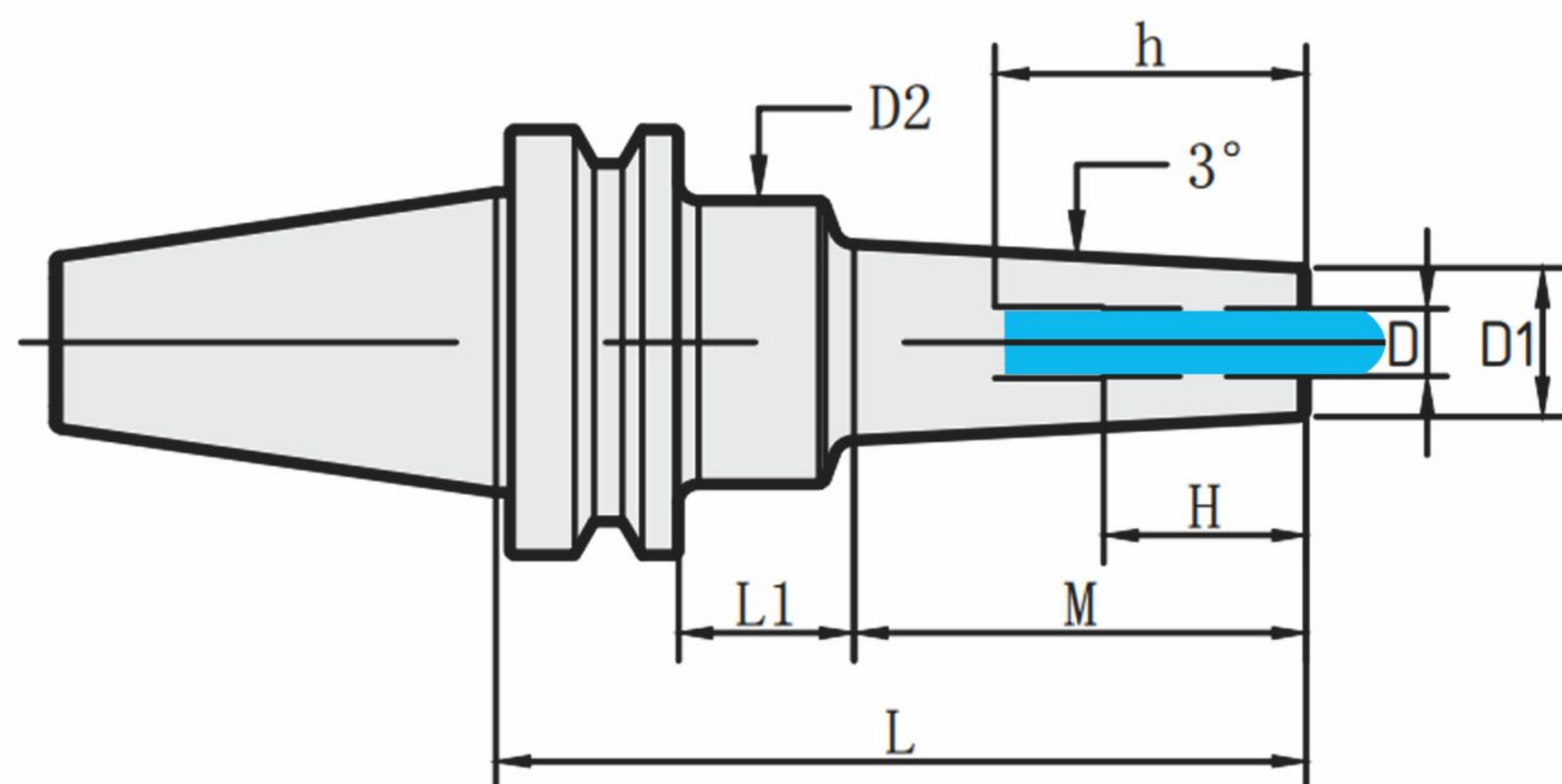
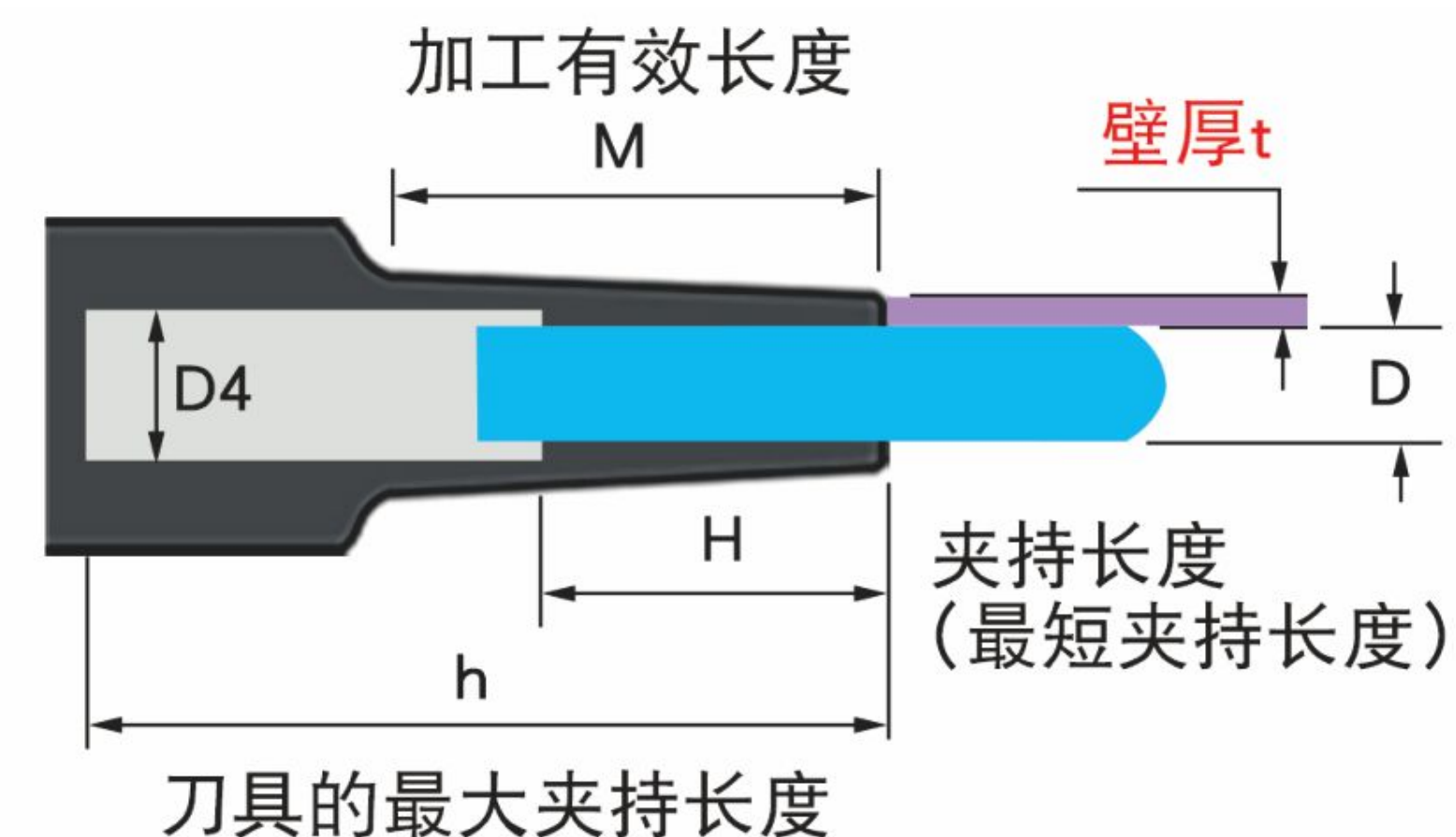
单位: mm

型号	图	D	D1	t	L	M	L1	L2	D2	D3	H	h	库存	
BT50 SHSA4-110-M 42	1	4	7	1.5	110	42	30	-	26	-	12	165		
-135-M 67					135	67			25				190	
-140-M 42					140	42	60						195	
-165-M 67					165	67			26				220	
-165-M 97					97	30			25					
-170-M 42	2				170	42	33	57			39		225	
-195-M 67					195	67							250	
-195-M 97	1				97	60	-				-			
-225-M 97	2				225	97	33	57	26	40			280	
BT50 SHRA4- 90-M 22	1	4	10		3	90	22	30	-	25	-	12	145	
-110-M 42				110		42			26				165	●

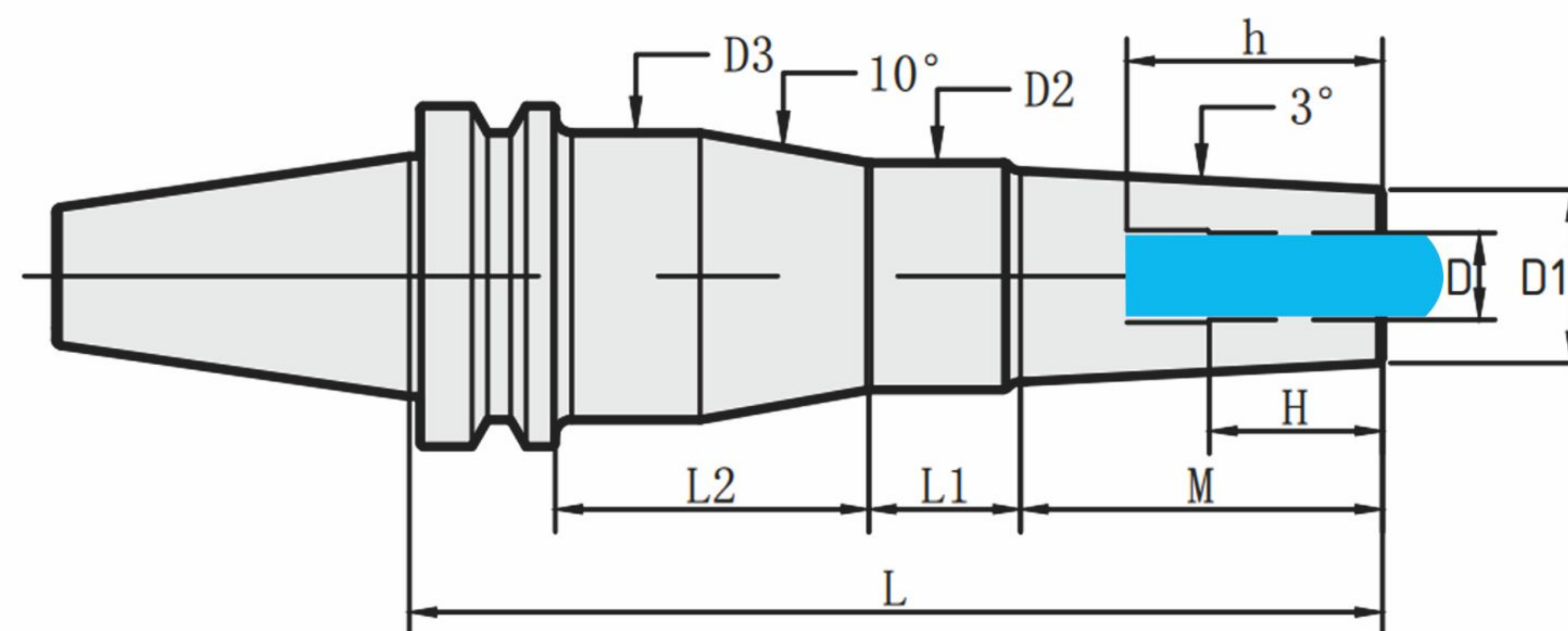
型号	图	D	D1	t	L	M	L1	L2	D2	D3	H	h	库存	
BT50 SHRA4-120-M 22	1	4	10	3	120	22	60	-	25	-	12	175		
-135-M 67					135	67	30			26			190	●
-140-M 42					140	42	60						195	
-150-M 22	2				150	22	33	57	25	39			205	
-165-M 67	1				165	67	60	-	26	-			220	●
-165-M 97					97	30								
-170-M 42	2				170	42	33	57			40		225	
-195-M 67					195	67							250	
-195-M 97	1				97	60	-			-				○
-195-M127					127	30			36					
-225-M 97	2				225	97	33	57	26	40			280	○

BT50 整体式热胀刀柄(不锈钢材质)

型号	图	D	D1	t	L	M	L1	L2	D2	D3	H	h	库存							
BT50 SHRA4-225-M127	1	4	10	3	225	127	60	-	36	-	12	280								
-255-M127	2				255	127	30	60	32	46			310							
BT50 SHSA6-110-M 42	1	6	9	1.5	110	42	30	-	26	-	18	165								
-135-M 67					135	67								190						
-140-M 42					140	42	60							195						
-165-M 67					165	67								220						
-165-M 97						97	30			36										
-170-M 42	2							170	42	33		57	26	40		225				
-195-M 67								195	67							250				
-195-M 97	1								97	60		-	36	-						
-225-M 97	2							225	97	28		62		50		280				
BT50 SHSB6-110-M 42	1				6	10	2	110	42	30		-	26	-	18	165	●			
-135-M 67								135	67							25			190	●
-140-M 42								140	42	60									195	
-165-M 67								165	67							26			220	●
-165-M 97									97	30				32						
-170-M 42	2							170	42	33	57	25	39			225				
-195-M 67								195	67			26	40			250				
-195-M 97	1								97	60	-	32	-				○			
-195-M127									127	30		36								
-225-M 97	2							225	97	28	62		50			280	○			
-225-M127	1								127	60	-		-							
-225-M157									157	30										
-255-M127	2							255	127	28	62		50			310				
-255-M157	1								157	60	-		-							
-285-M157	2				285	157	30	60	32	46		340								
BT50 SHRB6- 90-M 22	1	6	14	4	90	22	30	-	32	-	18	145								
-110-M 42					110	42									165	●				
-120-M 22					120	22	60								175					
-135-M 67					135	67	30			36					190	●				
-140-M 42					140	42	60								195					
-150-M 22	2							150	22	30		60	32	46		205				
-165-M 67	1							165	67	60		-		-		220	○			
-170-M 42	2							170	42	28		62	36	50		225				
-195-M 67								195	67	30		60	32	46		250				
BT50 SHSA8-110-M 42	1				8	11	1.5	110	42	30		-	25	-	24	165				
-135-M 67		120	67							36				190						

型号	图	D	D1	t	L	M	L1	L2	D2	D3	H	h	库存				
BT50 SHSA8-140-M 42	1	8	11	1.5	140	42	60	-	36	-	24	195					
-165-M 67					165	67						32			220		
-165-M 97						97	30					36					
-170-M 42	2							170	42	33		57	25	39		225	
-195-M 67								195	67	28		62	36	50		250	
-195-M 97	1								97	60		-		-			
-225-M 97	2							225	97	28		62		50		280	
BT50 SHSB8-110-M 42	1				8	13	2.5	110	42	30		-	32	-	24	165	●
-135-M 67		120	67											190		●	
-140-M 42		125	42	60							36			195			
-165-M 67		150	67											220		●	
-165-M 97			97	30						32							
-170-M 42	2							155	42		60		46			225	
-195-M 67								180	67			36				250	
-195-M 97	1								97	60	-		-				○
-195-M127									127	30							
-225-M 97	2							210	97	28	62	36	50			280	○
-225-M127	1								127	60	-	32	-				
-225-M157									157	30		42					
-255-M127	2							240	127	28	62	36	50			310	
-255-M157	1								157	60	-	42	-				
-285-M157	2				270	157	28	62		56		340					
BT50 SHRB8- 90-M 22	1	8	18	5	90	22	30	-	32	-	24	145					
-110-M 42					110	42						36			165	●	
-120-M 22					120	22	60								175		
-135-M 67					135	67	30								190	●	
-140-M 42					140	42	60								195		
-150-M 22	2							150	22	30		60	32	46		205	
-165-M 67	1							165	67	60		-	36	-		220	○
-170-M 42	2							170	42	28		62		50		225	
-195-M 67					195	67	30	60	32	46		250					
BT50 SHSA10-110-M 42	1	10	13	1.5	110	42	30	-	25	-	30	165					
-135-M 67					135	67						36			190		
-140-M 42					140	42	60								195		
-165-M 67					165	67									220		
-165-M 97						97	30										
-170-M 42	2							170	42	33		57	25	39		225	

BT50 整体式热胀刀柄(不锈钢材质)

型号	图	D	D1	t	L	M	L1	L2	D2	D3	H	h	库存	
BT50 SHSA10-195-M 67	2	10	13	1.5	195	67	28	62	36	50	30	250		
-195-M 97	1					97	60	-	32	-				
-225-M 97	2					225	97	28	62	36	50		280	
BT50 SHSB10-110-M 42	1	10	16	3	110	42	30	-	32	-	30	165	●	
-135-M 67						135	67						190	●
-140-M 42						140	42	60		36			195	
-165-M 67						165	67			32			220	●
-165-M 97							97	30						
-170-M 42	2					170	42	28	62	36	50		225	
-195-M 67						195	67	30	60	32	46		250	
-195-M 97	1						97	60	-		-			○
-195-M127							127	30		42				
-225-M 97	2					225	97		60	32	46		280	○
-225-M127	1						127	60	-	50	-			
-225-M157							157	30						
-255-M127	2					255	127	28	62	42	56		310	
-255-M157	1						157	60	-	50	-			
-285-M157						285	157	90					340	
BT50 SHRB10- 90-M 22	1	10	22	6	90	22	30	-	32	-	30	145		
-110-M 42						110	42						165	●
-120-M 22						120	22	60					175	
-135-M 67						135	67	30		42			190	●
-140-M 42						140	42	60		36			195	
-150-M 22	2					150	22	30	60	32	46		205	
-165-M 67	1					165	67	60	-	42	-		220	○
-170-M 42	2					170	42	28	62	36	50		225	
-195-M 67						195	67			42	56		250	
BT50 SHSA12-110-M 42	1	12	15		1.5	110	42	30	-	32	-	30	165	
-135-M 67						135	67			36			190	
-140-M 42						140	42	60					195	
-165-M 67						165	67			32			220	
-165-M 97							97	30		36				
-170-M 42	2					170	42		60	32	46		225	
-195-M 67						195	67	28	62	36	50		250	
-195-M 97	1						97	60	-		-			
-225-M 97	2					225	97	28	62		50		280	
BT50 SHSB12-110-M 42	1	12	19	3.5		110	42	30	-	32	-	30	165	●

型号	图	D	D1	t	L	M	L1	L2	D2	D3	H	h	库存	
BT50 SHSB12-135-M 67	1	12	19	3.5	135	67	30	-	32	-	30	190	●	
-140-M 42						140	42	60		36			195	
-165-M 67						165	67						220	○
-165-M 97							97	30		42				
-170-M 42	2					170	42	28	60	36	50		225	
-195-M 67						195	67						250	
-195-M 97	1						97	60	-	42	-			
-195-M127							127	30		50				
-225-M 97						225	97	90					280	
-225-M127							127	60		42				
-225-M157							157	30						
-255-M127						255	127	90		50			310	
-255-M157							157	60		42				
-285-M157	2					285	157	25	62		56		340	
BT50 SHRB12- 90-M 22	1	12	26		7	90	22	30	-	50	-	30	145	
-110-M 42						110	42			42			165	●
-120-M 22						120	22	60					175	
-135-M 67						135	67	30					190	●
-140-M 42						140	42	60		50			195	
-150-M 22						150	22	28	62	42	56		205	
-165-M 67						165	67	60	-		-		220	○
-170-M 42						170	42	28	62		56		225	
-195-M 67					195	67						250		
BT50 SHSB16-110-M 42	1	16	24	4	110	42	30	-	42	-	32	165	●	
-135-M 67						135	67						190	●
-140-M 42						140	42	60		50			195	
-165-M 67						165	67			42			220	●
-165-M 97							97	30						
-170-M 42						170	42	28	62		56		225	
-195-M 67						195	67	90	-	50	-		250	
-195-M 97							97	60						○
-195-M127							127	30						
-225-M 97						225	97	28	62	42	56		280	○
-225-M127							127	60	-	53	-			
-225-M157							157	30		50				
-255-M127					255	127	28	62	53	67		310		
-255-M157						157	60	-		-				

BT50 整体式热胀刀柄(不锈钢材质)

型号	图	D	D1	t	L	M	L1	L2	D2	D3	H	h	库存	
BT50 SHSB16-285-M157	1	16	24	4	285	157	28	62	53	67	32	340		
BT50 SHRB16- 90-M 22	1	16	32	8	90	22	30	-	50	-	32	145	○	
-110-M 42					110	42							165	●
-120-M 22					120	22	60						175	
-135-M 67					135	67	30		42				190	●
-140-M 42					140	42	60		50				195	
-150-M 22	2				150	22	28	62	42	56			205	
-165-M 67	1				165	67	60	-	50	-			220	●
-170-M 42	2				170	42	28	62	42	56			225	
-195-M 67	1				195	67	90	-	50	-			250	●
-195-M 97						97	60		53					●
-195-M127						127	30							●
-225-M 97	2				225	97	28	62		67			280	○
-225-M127	1					127	60	-	50	-				○
-225-M157						157	30		53					○
-255-M127	2				255	127	28	62		67			310	○
-255-M157	1					157	60	-		-				○
BT50 SHSB20-110-M 42	1	20	29	4.5	110	42	30	-	42	-	40	165		
-135-M 67					135	67							190	○
-140-M 42					140	42	60		50				195	●
-165-M 67					165	67							220	
-165-M 97						97	30		53					●
-170-M 42	2				170	42	28	62	42	56			225	○
-195-M 67	1				195	67	90	-	50	-			250	
-195-M 97						97	60		53					
-195-M127						127	30							●
-225-M 97	2				225	97	28	62		67			280	○
-225-M127	1					127	60	-	50	-				
-225-M157						157	30		53					
-255-M127	2				255	127	28	62		67			310	
-255-M157	1					157	60	-		-				
-285-M157	2			285	157	28	62		67			340		
BT50 SHRB20-110-M 42	1	20	38	9	110	42	30	-	53	-	40	165		
-135-M 67					135	67							190	●
-140-M 42					140	42	60		50				195	●
-165-M 67					165	67			53				220	○
-170-M 42	2				170	42	28	62		67			225	●
-195-M 67					195	67							250	○

型号	图	D	D1	t	L	M	L1	L2	D2	D3	H	h	库存	
BT50 SHRB25-110-M 42	1	16	32	8	110	42	30	-	53	-	45	165	●	
-140-M 42					140		60						195	●
-170-M 42					170	42	28	62	50	56			225	
-195-M 67					195	67	90	-		-			250	●
-195-M 97						97	60		53					●
-195-M127						127	30							●
-225-M 97	2				225	97	28	62		67			280	○
-225-M127	1					127	60	-	50	-				○
-225-M157						157	30		53					○
-255-M127	2				255	127	28	62		67			310	○
-255-M157	1					157	60	-		-				○

BT50 整体式热胀刀柄(不锈钢材质)

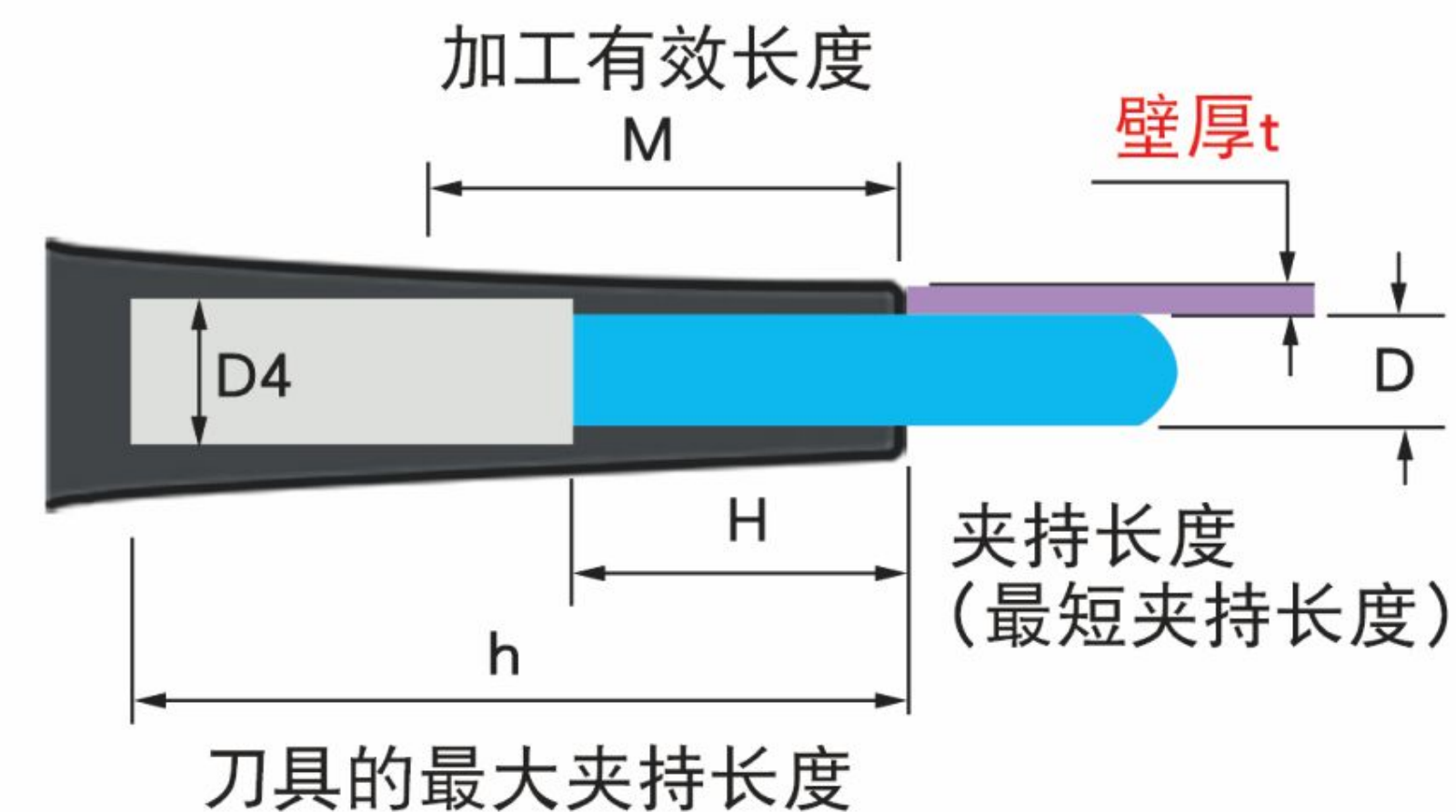
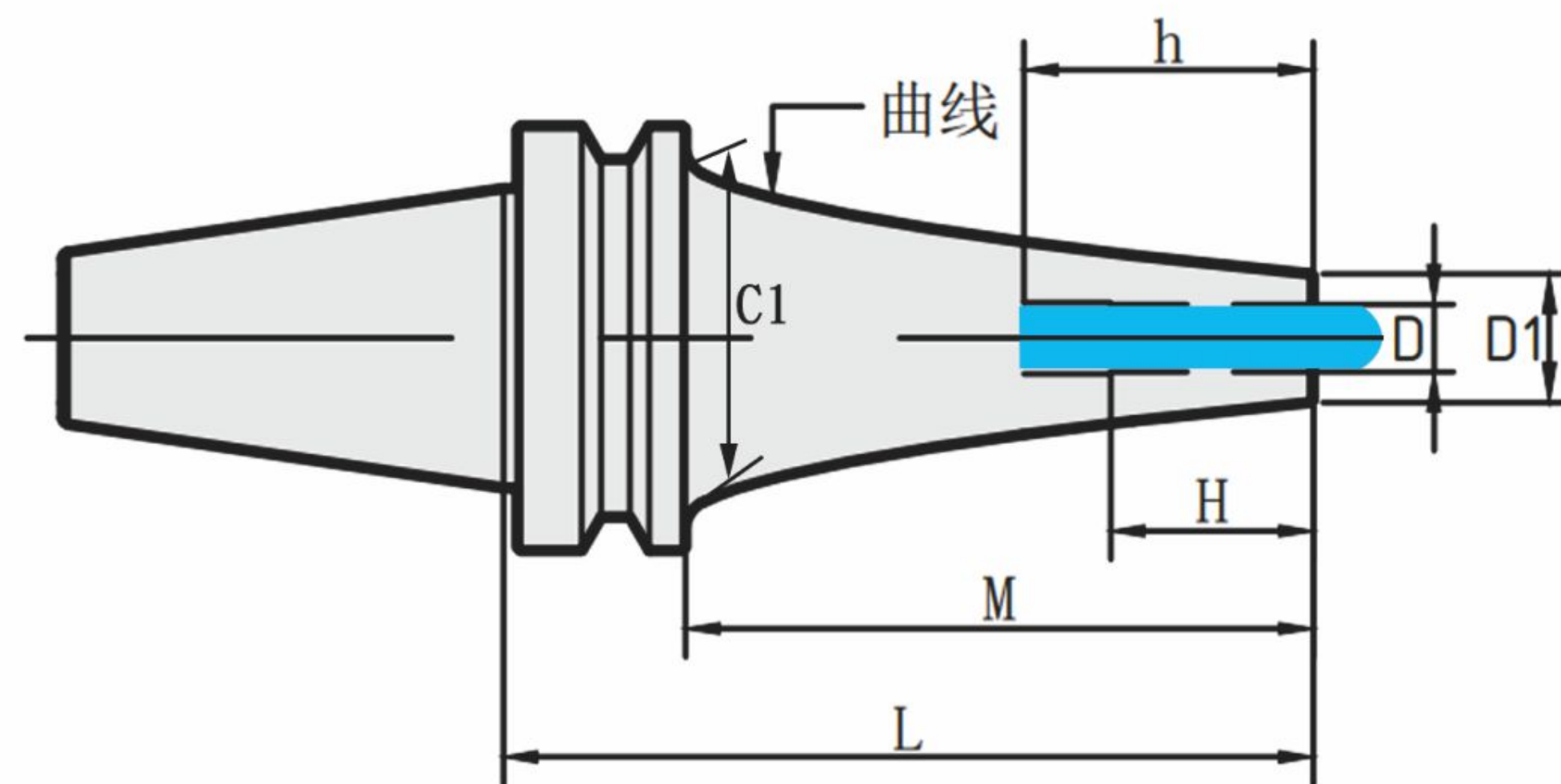

● 为常备库存 ○ 为少量库存

单位: mm

型号	D	D1	t	L	M	C1	D4	D2	D3	H	h	库存
BT50 SHSA4-165 CV	4	7	1.5	165	127	85	5	-	-	13	220	○
-195 CV				195	157						250	○
-225 CV				225	187						280	○
-255 CV				255	217						310	○
-285 CV				285	247						340	
-315 CV				315	277						370	
BT50 SHSA6-165 CV	6	9	1.5	165	127	85	7	-	-	18	220	○
-195 CV				195	157						250	○
-225 CV				225	187						280	○
-255 CV				255	217						310	○
-285 CV				285	247						340	
-315 CV				315	277						370	
BT50 SHSA8-165 CV	8	11	1.5	165	127	85	9	-	-	24	220	○
-195 CV				195	157						250	○
-225 CV				225	187						280	○
-255 CV				255	217						310	○
-285 CV				285	247						340	
-315 CV				315	277						370	
BT50 SHRA8-195 CV	8	16	4	195	157	85	9	-	-	24	250	○
-225 CV				225	187						280	○
-255 CV				255	217						310	○
-285 CV				285	247						340	

型号	D	D1	t	L	M	C1	D4	D2	D3	H	h	库存
BT50 SHSA10-165 CV	10	13	1.5	165	127	85	11	-	-	30	220	○
-195 CV				195	157						250	○
-225 CV				225	187						280	○
-255 CV				255	217						310	○
-285 CV				285	247						340	
-315 CV				315	277						370	
BT50 SHRA10-165 CV	10	19	4.5	165	127	85	11	-	-	30	220	○
-195 CV				195	157						250	○
-225 CV				225	187						280	○
-255 CV				255	217						310	○
-285 CV				285	247						340	
BT50 SHSA12-165 CV	12	15	1.5	165	127	84	13	-	-	30	220	○
-195 CV				195	157						250	○
-225 CV				225	187						280	○
BT50 SHSA12-255 CV	12	15	1.5	255	217	85	13	-	-	30	310	○
-285 CV				285	247						340	
-315 CV				315	277						370	
BT50 SHRA12-165 CV	10	19	4.5	165	127	85	14	-	-	30	220	○
-195 CV				195	157		13				250	○
-225 CV				225	187		280				○	
-255 CV				255	217		315				○	
-285 CV	285	247	340									

HSK A50 整体式热胀刀柄(不锈钢材质)

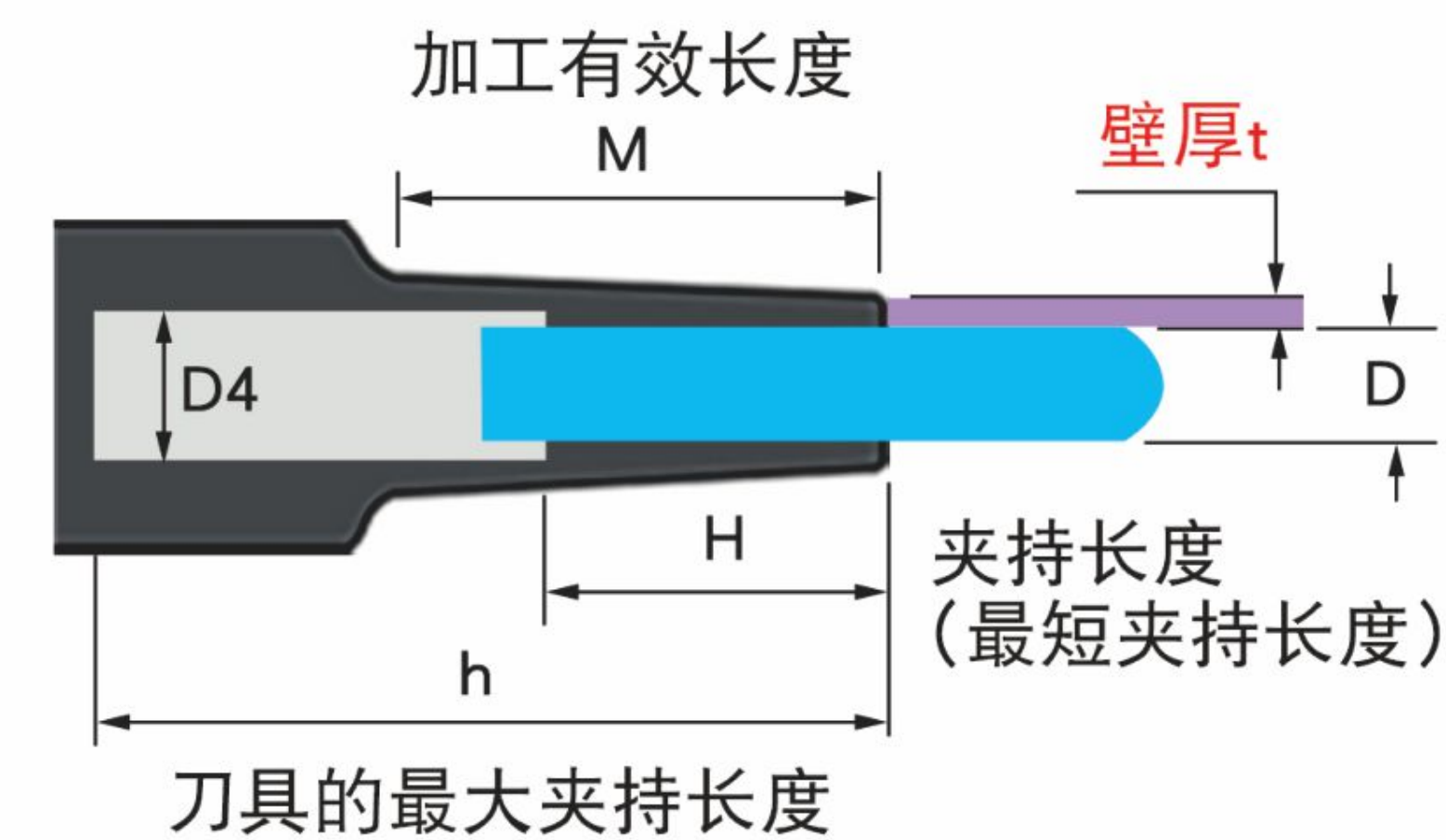
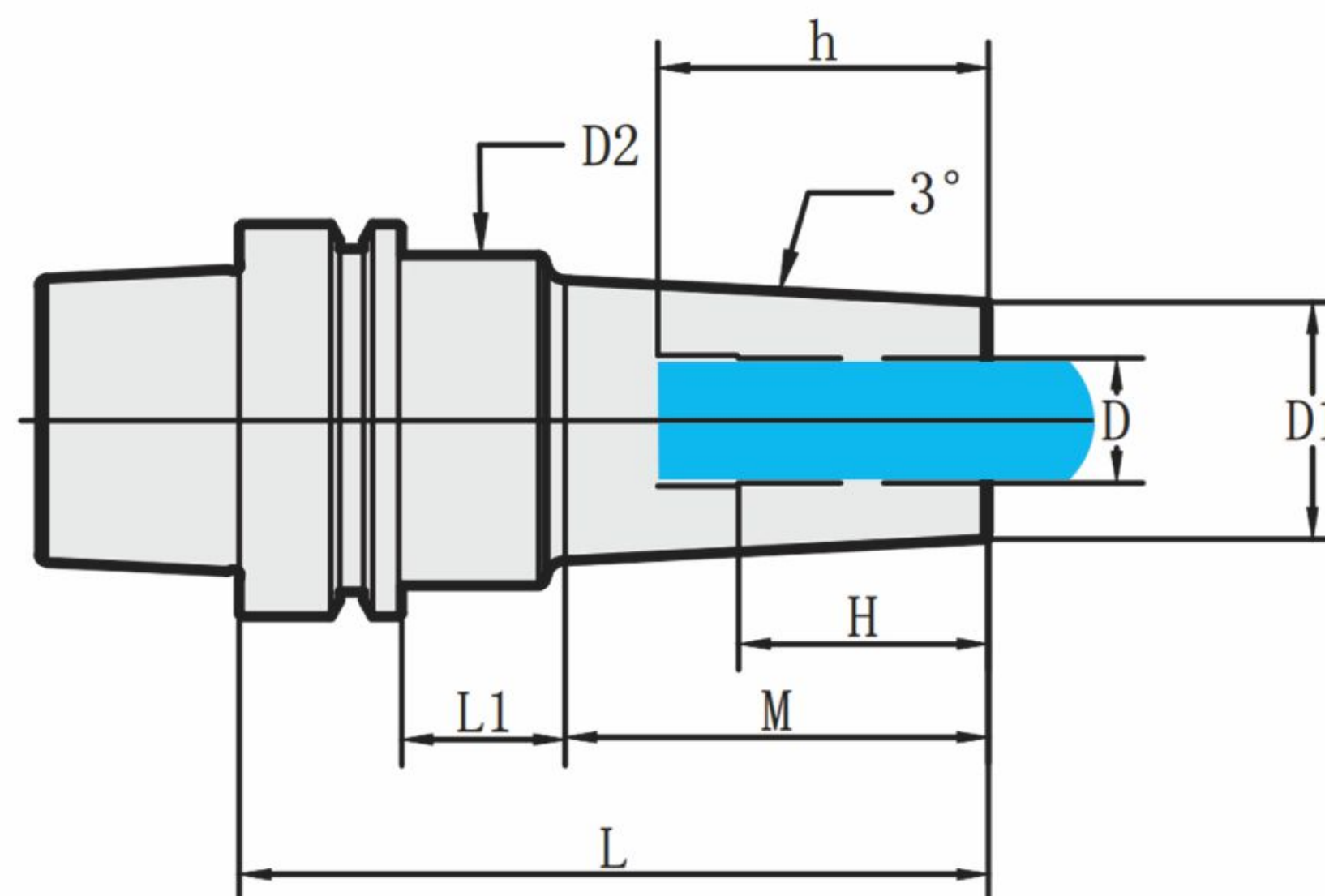

● 为常备库存 ○ 为少量库存

单位: mm

型号	D	D1	t	L	M	L1	D4	D2	D3	H	h	库存
HSK A50 SHSA4- 60-M 22	4	7	1.5	60	22	12	5	20	9.3	13	50	○
- 75-M 22				75	22	27		25	61		●	
- 80-M 42				80	42	12		20	11.4		70	●
- 95-M 42				95	42	27		25	85		●	
HSK A50 SHRA4- 75-M 22	4	10	3	75	22	27	5	25	12.3	13	61	
- 95-M 42				95	42			14.4	81			
- 120-M 67				120	67			17	106			
- 150-M 97				150	97			20.2	135			
HSK A50 SHSA6- 60-M 22	6	9	1.5	60	22	12	7	20	11.3	18	42	●
- 75-M 22				75	22	27		25	61		●	
- 80-M 42				80	42	12		20	13.4		62	●
- 95-M 42				95	42	27		25	81		○	
- 120-M 67				120	67				16		106	○
- 150-M 97				150	97			32	19.2		135	●
HSK A40 SHRA6- 60-M 22	6	12	3	60	22	12	6.6	26	14.3	18	44	●
- 75-M 22				75	22	27	7	25	61		●	
- 95-M 42				95	42			16.4	81		○	
- 120-M 67				120	67			19	106			

型号	D	D1	t	L	M	L1	D4	D2	D3	H	h	库存
HSK A50 SHSB6- 95-M 42	6	10	2	95	42	27	6.6	25	14.4	18	77	○
- 120-M 67				120	67		7	17	102		●	
- 150-M 97				150	97		32	20.2	135		●	
HSK A50 SHRB6- 95-M 42	6	14	4	95	42	27	7	32	18.4	18	80	●
HSK A50 SHSA8- 65-M 22	8	11	1.5	65	22	17	8.6	26	13.3	24	49	
- 75-M 22				75	22	27	9	25	15.4		61	
- 85-M 42				85	42	17	8.6	26	67			
- 95-M 42				95	42	27	9	25	81			
- 120-M 67				120	67			32	18		105	●
- 150-M 97				150	97			21.2	132		●	
HSK A50 SHRA8- 60-M 22	6	14	3	60	22	12	8.6	26	16.3	20	44	●
- 75-M 22				75	22	27	9	25	61		○	
- 95-M 42				95	42			18.4	81		○	
HSK A50 SHSB8- 95-M 42	8	13	2.5	95	42	27	9	32	17.4	24	77	●
- 120-M 67				120	67			20	105		●	
- 150-M 97				150	97			23.2	132		●	
HSK A50 SHRB8- 95-M 42	8	18	5	95	42	27	9	32	22.4	24	77	○
- 120-M 67				120	67			25	105			

HSK A50 整体式热胀刀柄(不锈钢材质)

型号	D	D1	t	L	M	L1	D4	D2	D3	H	h	库存
HSK A50 SHSA10-65-M 22	10	13	1.5	65	22	17	10.6	26	15.3	30	49	
- 75-M 22				75	22	27	11	25			61	○
- 85-M 42				85	42	17	10.6	26	17.4		64	●
- 95-M 42				95	42	27	11	25			81	●
-120-M 67				120	67		32	20	105		●	
-150-M 97				150	97			23.2	135		○	
HSK A50 SHRA10-60-M 22	10	16	3	60	22	12	10.6	26	18.3	25	44	
- 75-M 22				75	22	27	11	25		30	60	
HSK A50 SHSB10-95-M 42	10	16	3	95	42	27	11	32	20.4	30	80	○
-120-M 67				120	67			23	105		●	
-150-M 97				150	97			26.2	135		●	
HSK A50 SHRB10-95-M 42	10	22	6	95	42	27	11	32	26.4	30	64	●
-120-M 67				120	67		42	29	107			
HSK A50 SHSA12-65-M 22	12	15	1.5	65	22	17	12.6	26	17.3	25	49	○
- 75-M 22				75	22	27	13	25		30	60	○
- 85-M 42				85	42	17	12.6	26	19.4	64	○	
- 95-M 42				95	42	27	13	32		80	○	
-120-M 67				120	67			22	105	○		
HSK A50 SHRA12-60-M 22	12	20	4	60	22	12	12.6	26	22.3	25	44	○
- 75-M 22				75	22	27	13	25		30	62	○
HSK A50 SHSB12-95-M 42	12	19	3.5	95	42	27	13	32	23.4	30	64	
-120-M 67				120	67			26	64			
-150-M 97				150	97			29.2	105			
HSK A50 SHRB12-95-M 42	12	26	7	95	42	27	13	42	30.4	30	82	
-120-M 67				120	67			33	64			
HSK A50 SHSB16-95-M 42	16	24	4	95	42	27	17	42	28.4	32	81	
-120-M 67				120	67			31	81			
HSK A50 SHRB16-75-M 22	16	32	8	75	22	27	17	42	34.3		62	●
HSK A50 SHRA16-60-M 22	16	26	5	60	22	12	16.6	34	28.3	32	44	●
HSK A50 SHSB20-95-M 42	20	29	4.5	95	42	27	21	42	33.4	40	82	○
HSK A50 SHRA20-65-M 22	20	32	6	65	22	17	20.6	40	34.3	38	49	

HSK A50 整体式热胀刀柄(不锈钢材质)



图1

● 为常备库存 ○ 为少量库存

单位: mm

型号	D	D1	t	L	M	L1	L2	C1	D4	H	h	库存
HSK A50 SHSA4- 90 CV	4	7	1.5	90	64	-	-	42	5	13	74	○
-120 CV				120	94						104	●
-150 CV				150	124						134	●
-180 CV				180	154						164	●
HSK A50 SHRA6-120 CV	4	10	3	120	94	-	-	42	5	13	104	
-150 CV				150	124						134	
HSK A50 SHRA6- 90 CV	6	9	1.5	90	64	-	-	42	7	18	74	
-120 CV				120	94						104	
-150 CV				150	124						134	●
-180 CV				180	154						164	●
HSK A50 SHRA6-120 CV	6	13	3.5	120	94	-	-	42	7	18	104	●
-150 CV				150	124						132	○
HSK A50 SHSA8- 90 CV	8	11	1.5	90	64	-	-	42	9	24	74	○
-120 CV				120	94						104	●
-150 CV				150	124						134	●
-180 CV				180	154						164	●
HSK A50 SHRA8-120 CV	8	16	4	120	94	-	-	42	9	24	102	○
-150 CV				150	124						132	

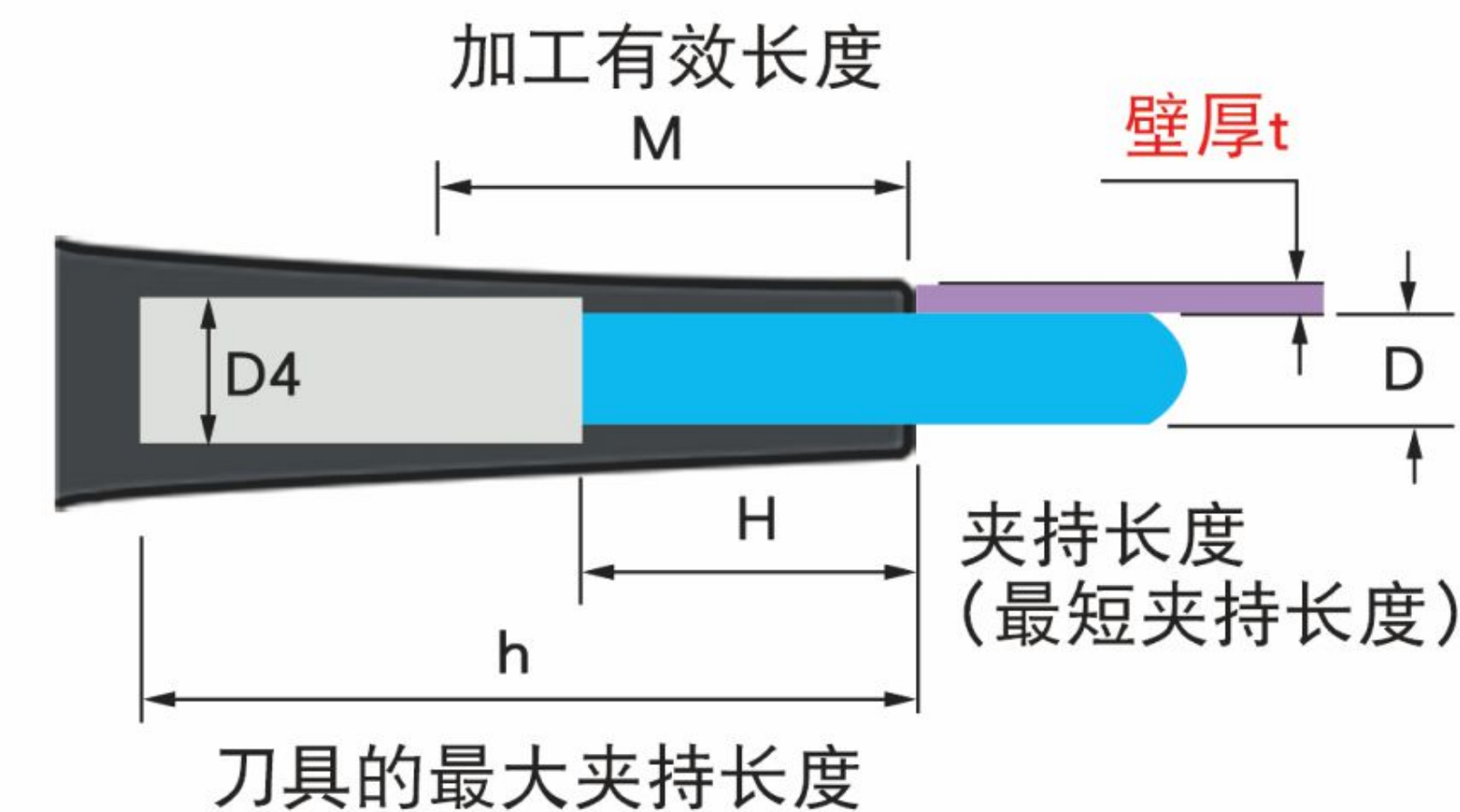
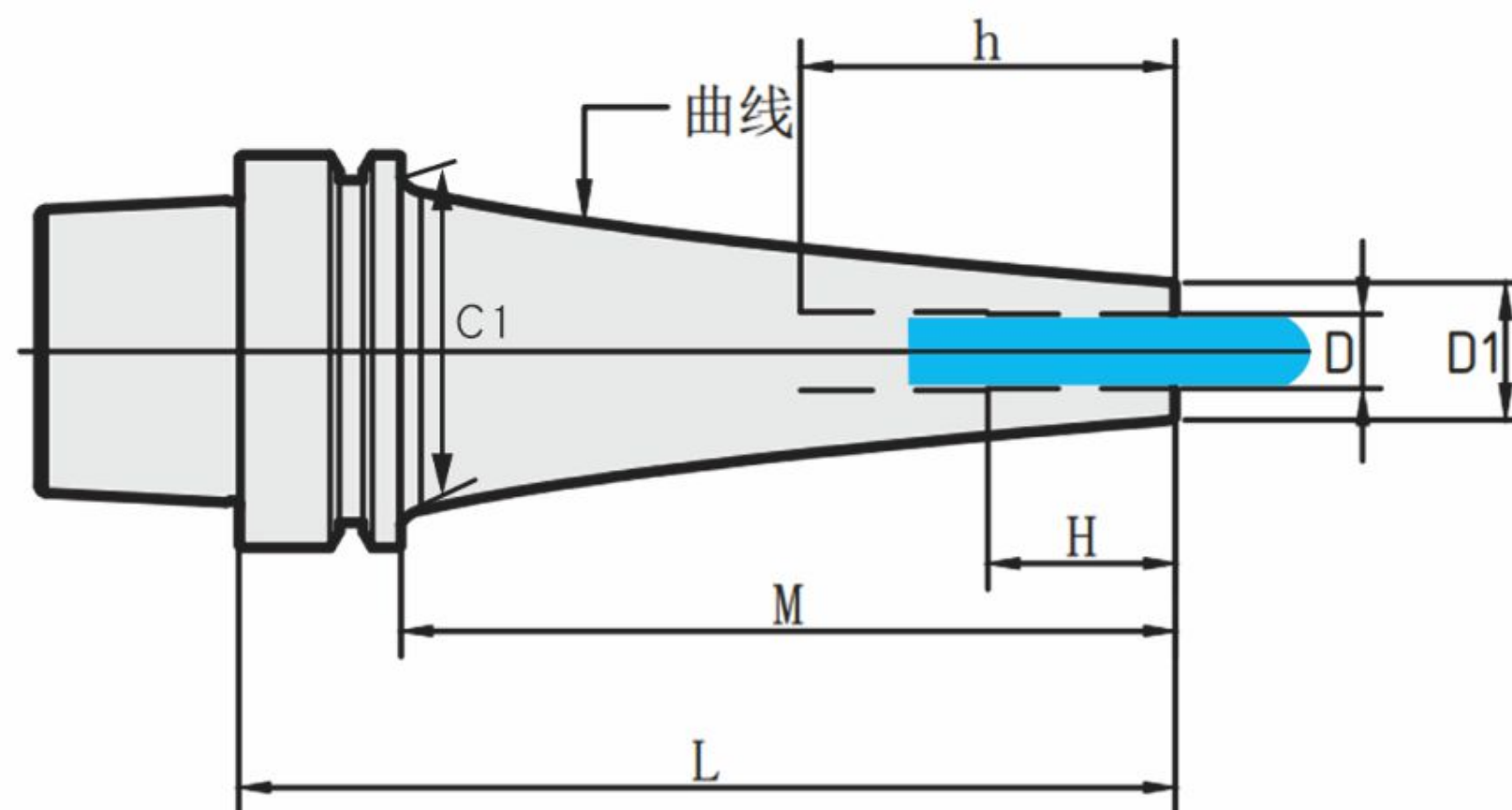
型号	D	D1	t	L	M	L1	L2	C1	D4	H	h	库存
HSK A50 SHSA10- 90 CV	10	19	4.5	90	64	-	-	42	11	30	74	
-120 CV				120	94						104	
-150 CV				150	124						134	
-180 CV				180	154						164	
HSK A50 SHRA10-150 CV	10	19	4.5	150	124	-	-	42	11	30	132	

HSK A63 整体式热胀刀柄(不锈钢材质)



图1



图2

● 为常备库存 ○ 为少量库存

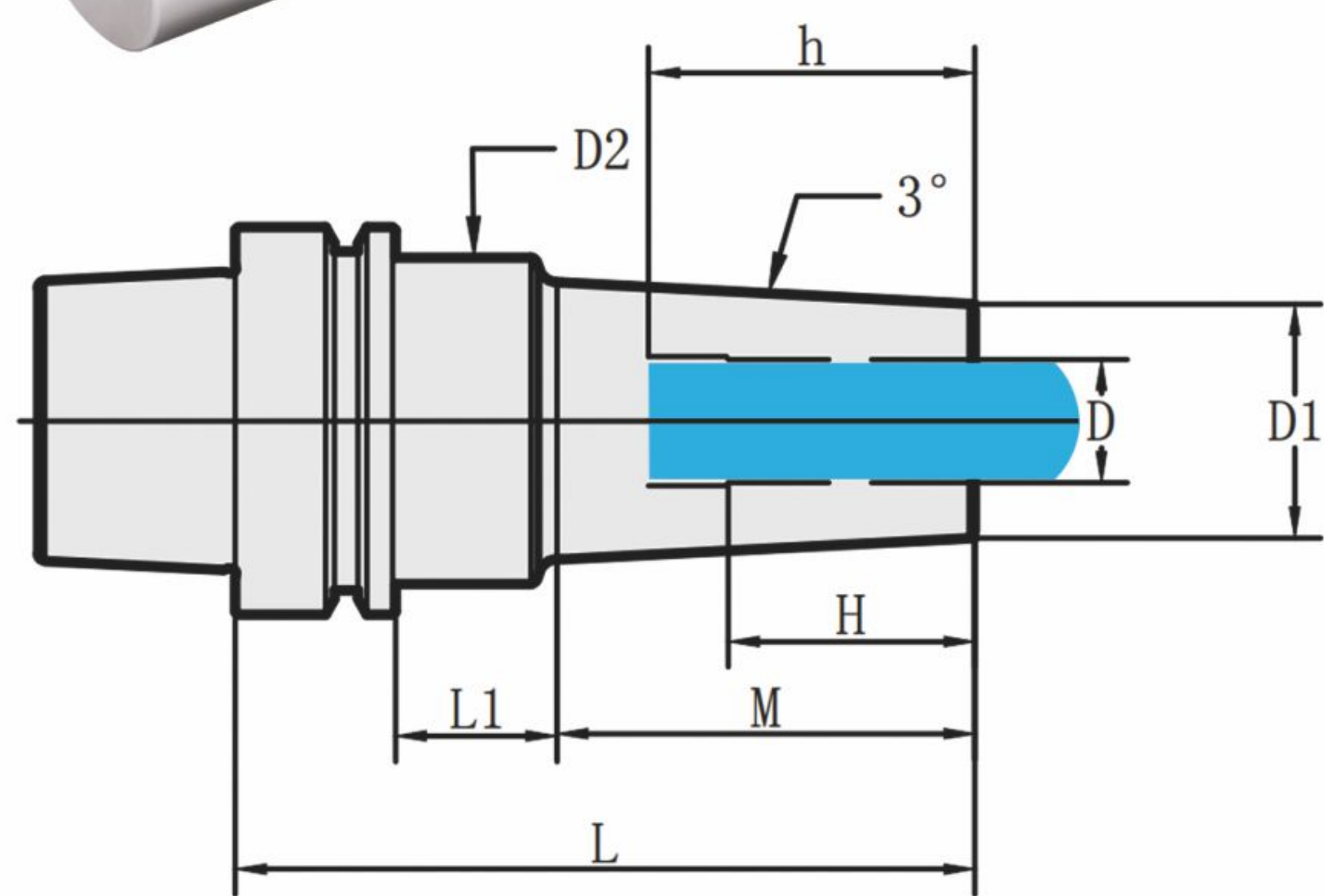
单位: mm

型号	图	D	D1	t	L	M	L1	L2	D2	D3	H	h	库存	
HSK A63 SHSA4 - 95-M 42	1	4	7	1.5	95	42	27	-	25	-	12	72	○	
-120-M 67	1	4	7		120	67						97	○	
-125-M 42	1	4	7		125	42	57					100	○	
-150-M 67	1	4	7		150	67						127	○	
-150-M 97	1	4	7		150	67	27						○	
-155-M 42	2	4	7		155	42	33	54			39		130	○
-180-M 67	2	4	7		180	67			26	40			157	○
-180-M 97	1	4	7		180	67	57	-		-				○
-210-M 97	2	4	7		210	97	33	54	25	39			187	○
HSK A63 SHRA4 - 75-M 42	1	4	10		3	75	22	27	-	25	-	12	50	○
- 95-M 42	1	4	10	95		42							72	●

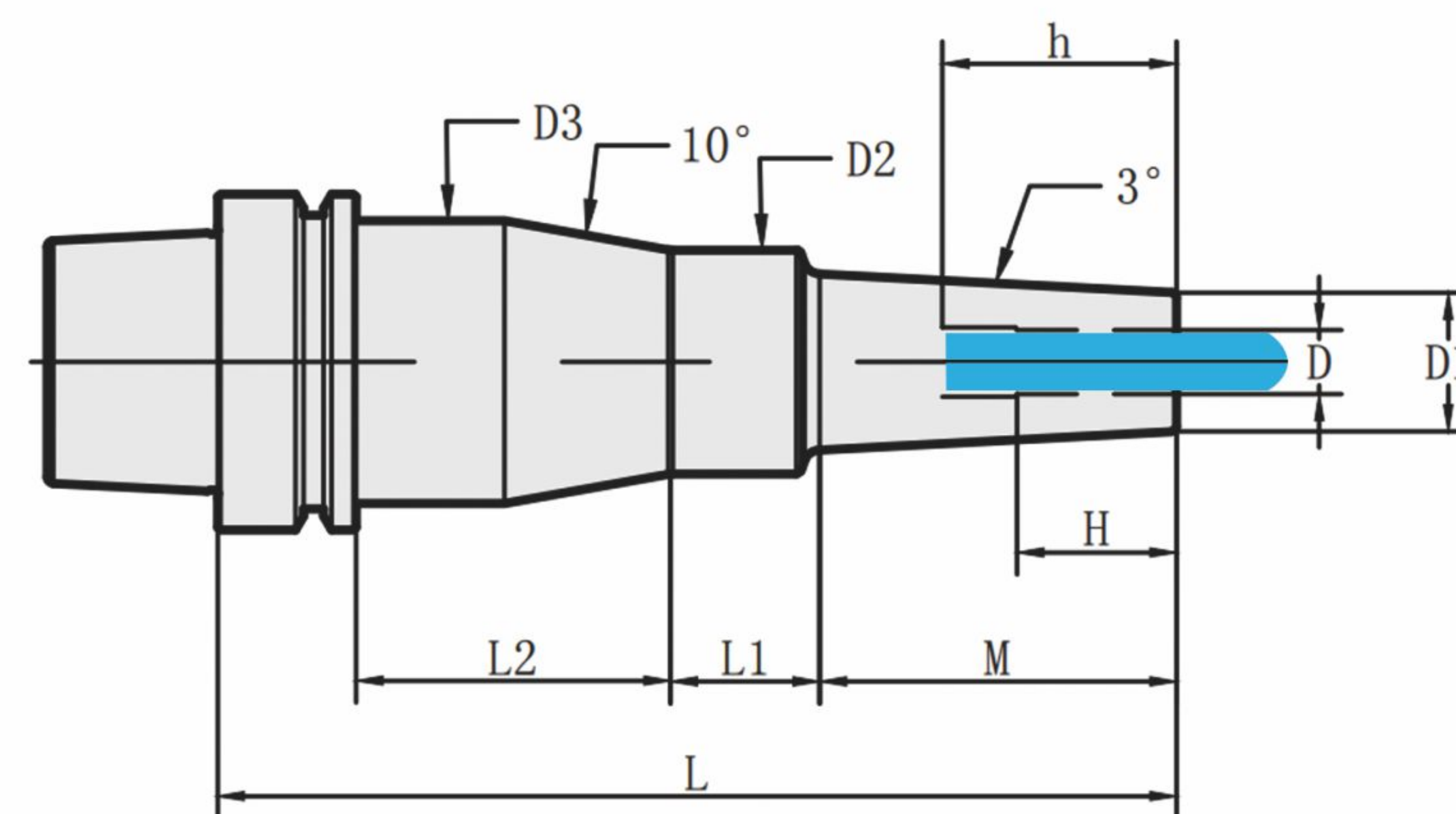
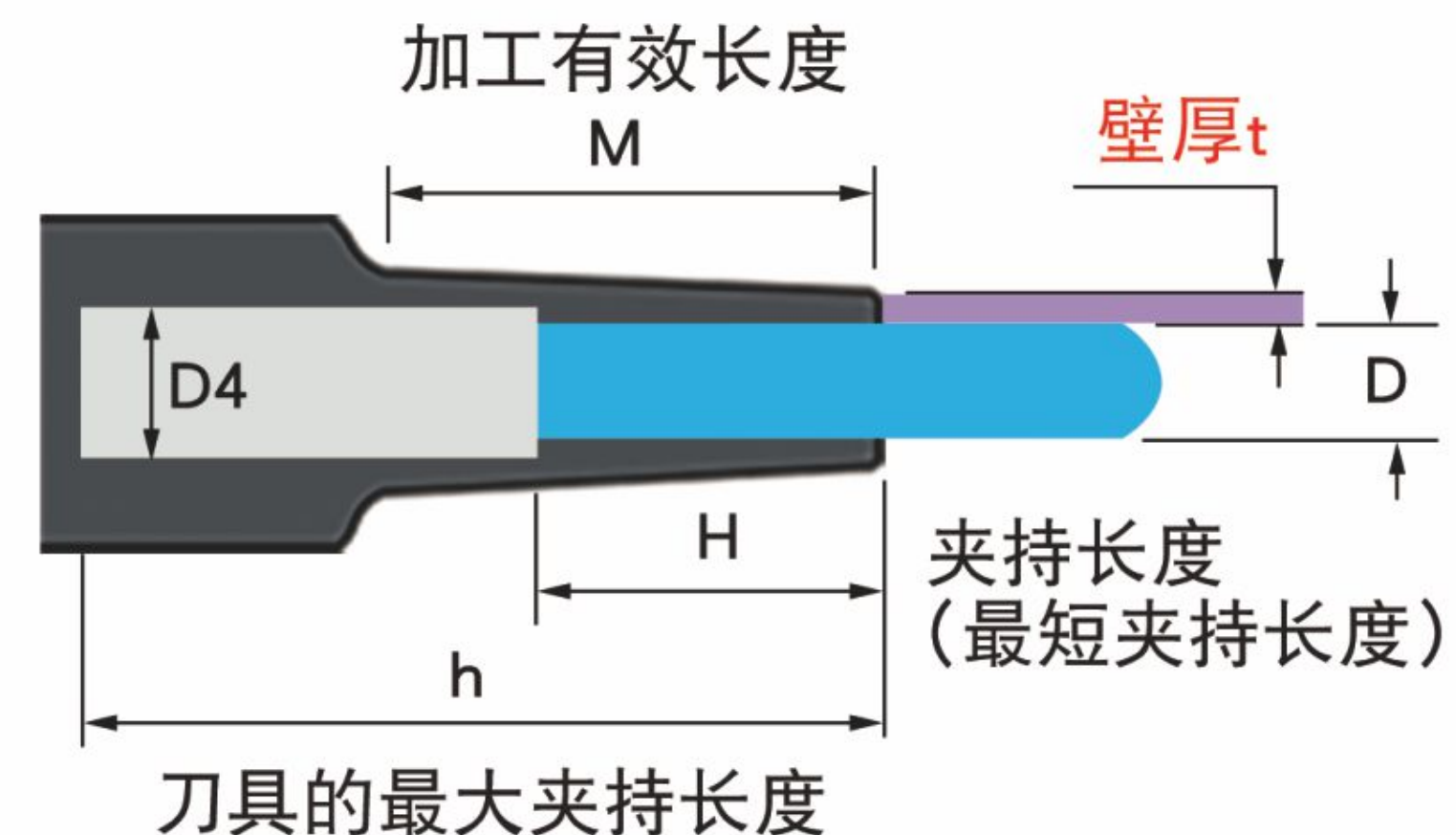
型号	图	D	D1	t	L	M	L1	L2	D2	D3	H	h	库存	
HSK A63 SHRA4 -105-M 22	1	4	10	3	105	42	57	-	26	-	12	80		
-120-M 67	1	4	10		120	67	27			25			100	●
-125-M 42	1	4	10		125	42	57			26			105	○
-135-M 22	2	4	10		135	22	33	54			40		110	
-150-M 67	1	4	10		150	67	57	-			-		130	●
-150-M 97	1	4	10		150	67	27			25				○
-155-M 42	2	4	10		155	42	33	54			39		135	○
-180-M 67	1	4	10		180	67							157	○
-180-M 97	1	4	10		180	67	57	-		26	-			●
-180-M127	1	4	10		180	67	27			36				○
-210-M 97	2	4	10		210	97	33	54	26	40			180	

HSK A63 整体式热胀刀柄(不锈钢材质)

型号	图	D	D1	t	L	M	L1	L2	D2	D3	H	h	库存	
HSK A63 SHRA4-210-M127	1	4	10	3	210	127	57	-	36	-	12	187	○	
-240-M127	2				240	127	28	59			50		220	
HSK A63 SHSA6- 95-M 42	1	6	9	1.5	95	42	27		25	-	18	70	○	
-120-M 67					120	67							100	○
-125-M 42					125	42	57						105	○
-150-M 67					150	67		54	26				130	○
-150-M 97						97	27		32					○
-155-M 42	2				155	42	33	-	25	39			135	○
-180-M 67					180	67		54	26	40			157	○
-180-M 97	1					97	57	-	36	-				○
-210-M 97	2				210	97	28	59			59		190	○
HSK A63 SHSB6- 95-M 42	1	6	10		2	95	42	27	-	26	-	18	72	○
-120-M 67				120		67			25				100	●
-125-M 42				125		42	57		26				105	○
-150-M 67				150		67			25				130	●
-150-M 97						97	27		36					○
-155-M 42	2			155		42	33	54	25	39			135	○
-180-M 67				180		67							157	
-180-M 97	1					97	57	-	36	-				●
-180-M127						127	27							○
-210-M 97	2			210		97	28	59			50		187	
-210-M127	1					127	57	-						○
-210-M157						157	27							○
-240-M127	2			240		127	28	59			50		220	
-240-M157	1					157	57	-						
-270-M157	2			270		157	30	57	32	46			250	
HSK A63 SHRB6- 75-M 22	1	6	14	4	75	22	27	-	32	-	18	50	○	
- 95-M 42					95	42							72	●
-105-M 22					105	22	57		36				80	
-120-M 67					120	67	27						100	●
-125-M 42					125	42	57						105	○
-135-M 22	2				135	22	28	59			50		115	
-150-M 67	1				150	67	57	-	32	-			130	●
-155-M 42	2				155	42	30	57		46			135	○
-180-M 67					180	67							157	●
HSK A63 SHSA8- 95-M 42	1	8	11		1.5	95	42	27	-	36	-	24	70	
-120-M 67				120		67							100	○

型号	图	D	D1	t	L	M	L1	L2	D2	D3	H	h	库存	
HSK A63 SHSA8-125-M 42	1	8	11	1.5	125	42	57	-	36	-	24	105	○	
-150-M 67					150	67							130	○
-150-M 97						97	27							○
-155-M 42	2				155	42	33	54	25	39			135	○
-180-M 67					180	67	30	57	32	46			157	○
-180-M 97	1					97	57	-	36	-				○
-210-M 97	2				210	97	28	59			50		187	○
HSK A63 SHSB8- 95-M 42	1	8	13		2.5	95	42	27	-	36	-	24	72	○
-120-M 67				120		67				32			100	●
-125-M 42				125		42	57			36			105	
-150-M 67				150		67				32			130	●
-150-M 97						97	27							○
-155-M 42	2			155		42	30	57		46			135	
-180-M 67				180		67							157	
-180-M 97	1					97	57	-	36	-				●
-180-M127						127	27							○
-210-M 97	2			210		97		59			50		187	
-210-M127	1					127	57	-						○
-210-M157						157	27							○
-240-M127	2			240		127	30	57	32	46			217	
-240-M157	1					157	57	-	36	-				
-270-M157	2			270		157	28	59			50		247	
HSK A63 SHRB8- 75-M 22	1	8	18	5	75	22	27	-	32	-	24	50	○	
- 95-M 42					95	42							72	●
-105-M 22					105	22	57			36			80	
-120-M 67					120	67	27			32			100	●
-125-M 42					125	42	57			36			105	○
-135-M 22	2				135	22	30	57	32	46			115	
-150-M 67	1				150	67	57	-	36	-			130	●
-155-M 42	2				155	42	30	57	32	46			135	○
-180-M 67				180	67							157	○	
HSK A63 SHSA10- 95-M 42	1	10	13	1.5	95	42	27	-	36	-	30	72		
-120-M 67					120	67							100	○
-125-M 42					125	42	57						105	○
-150-M 67					150	67							130	○
-150-M 97						97	27							○
-155-M 42	2				155	42	33	54	25	39			135	○

HSK A63 整体式热胀刀柄(不锈钢材质)

型号	图	D	D1	t	L	M	L1	L2	D2	D3	H	h	库存	
HSK A63 SHSA 10-180-M67	2	10	13	1.5	180	67	30	57	32	46	30	157	○	
-180-M 97	1					97	57	-	36	-			○	
-210-M 97	2				210	97	30	57	32	46			187	○
HSK A63 SHSB10-95-M 42	1	10	16	3	95	42	27	-	36	-	30	72	○	
-120-M 67					120	67				32			100	●
-125-M 42					125	42	57			36			105	
-150-M 67					150	67							130	●
-150-M 97						97	27			32				○
-155-M 42	2				155	42	28	59	36	50			135	
-180-M 67					180	67							157	
-180-M 97	1					97	57	-		-				●
-180-M127						127	27			50				○
-210-M 97	2					210	97	28	59	36	50		187	
-210-M127	1						127	57	-	50	-			○
-210-M157							157	27						○
-240-M127						240	127	87					220	
-240-M157							157	57						
-270-M157						270	157	87					247	
HSK A63 SHRB10-75-M 22	1	10	22	6	75	22	27	-	36	-	30	50	○	
-95-M 42					95	42				32			72	●
-105-M 22					105	22	57			36			80	
-120-M 67					120	67	27						100	●
-125-M 42					125	42	57						105	○
-135-M 22	2				135	22	30	57	32	46			110	
-150-M 67	1				150	67	57	-	36	-			130	●
-155-M 42	2				155	42	28	59		50			135	○
-180-M 67					180	67			42	53			157	○
HSK A63 SHSA 12-95-M 22	1	12	15		1.5	95	42	27	-	36	-	30	72	
-120-M 67				120		67							100	○
-125-M 42				125		42	57						105	○
-150-M 67				150		67				32			127	○
-150-M 97						97	27			36				○
-155-M 42	2			155		42	30	57	32	46			135	○
-180-M 67				180		67							157	○
-180-M 97	2			180		97	57	-	36	-				○
-210-M 97	1			210		97	30	57	32	46			187	○
HSK A63 SHSB12-95-M 22	1	12	19	3.5	95	42	27	-	36	-	30	72	○	

型号	图	D	D1	t	L	M	L1	L2	D2	D3	H	h	库存	
HSK A63 SHSB12-120-M 67	1	12	19	3.5	100	67	27	-	36	-	30	100	●	
-125-M 42					125	42	57			32			105	
-150-M 67					150	67				36			127	●
-150-M 97						97	27			50				○
-155-M 42	2				155	42	30	57	32	46			135	
-180-M 67					180	67	28	59	36	50			157	
-180-M 97	1					97	57	-	50	-				●
-180-M127						127	27							○
-210-M 97					210	97	87						187	
-210-M127						127	57							○
-210-M157						157	27							○
-240-M127					240	127	87						217	
-240-M157						157	57							
-270-M157					270	157	87						257	
HSK A63 SHRB12-75-M 22	1	12	26		7	75	22	27	-	42	-	30	50	○
-95-M 42				95		42							72	●
-105-M 22				105		22	57			50			80	
-120-M 67				120		67	27						100	●
-125-M 42				125		42	57						105	○
-135-M 22	2			135		22	28	59	42	53			115	
-150-M 67	1			150		67	57	-	50	-			120	●
-155-M 42				155	42	87						127	○	
-180-M 67				180	67							157	○	
HSK A63 SHSB16-95-M 42	1	16	24	4	95	42	27	-	42	-	32	72	○	
-120-M 67					120	67				50			100	●
-125-M 42					125	42	57						105	
-150-M 67					150	67							127	●
-150-M 97						97	27							○
-155-M 42					155	42	87						130	
-180-M 67	2				180	67	28	59	42	53			157	
-180-M 97	1					97	57	-	50	-				●
-180-M127						127	27			53				○
-210-M 97					210	97	87			42	-		187	
-210-M127						127	57			53				○
-210-M157						157	27			50				○
-240-M127					240	127	87			53			217	
-240-M157						157	87			50				

HSK A63 整体式热胀刀柄(不锈钢材质)

型号	图	D	D1	t	L	M	L1	L2	D2	D3	H	h	库存										
HSK A63 SHSB16-270-M157	1	16	24	4	270	157	87	-	50	-	32	247											
HSK A63 SHRB16-75-M22	1	16	32	8	75	22	27	-	50	-	32	50	○										
-95-M42					95	42						72	●										
-105-M22					105	22	57					80	●										
-120-M67					120	67	27					100	●										
-125-M42					125	42	57					105	○										
-135-M22					135	22	87					130											
-150-M67					150	67	57					127											
-155-M42					155	42	87					135	○										
-180-M67					180	67						157	●										
-210-M67					2											53	210	67	28	89	50	187	●
-240-M67																	240	67		119		217	●
HSK A63 SHSB20-95-M42					1	20	29					4.5	95	42	27	-	50	-	40	72			
-120-M67													120	67						100	○		
-125-M42	125	42	57	105				○															
-150-M67	150	67		127				○															
-150-M97		97	27					○															
-155-M42	155	42	87	130				○															
-180-M67	180	67		157				○															
-180-M97		97	57					○															
-180-M127		127	27																				
-210-M97	210	97	87	187																			
-210-M127		127	57																				
-210-M157		157	27																				
-240-M127	240	127	87	217																			
-240-M157		157	57																				
-270-M157	270	157	87	247																			
HSK A63 SHRB20-95-M42	1	20	38	9	95	42	27	-	53	-	40	72	●										
-120-M67					120	67						100	●										
-125-M42					125	42	57					105	○										
-150-M67					150	67						127											
-155-M42					155	42	87					130	○										
-180-M67					180	67						157	●										
-210-M67					210	67	117					187	●										
-240-M67					240	67	147					217	●										
HSK A63 SHRB25-95-M22	1	25	45	10	95	22	27	-	53	-	45	72	●										
-125-M42					125	42	57					105	●										

型号	图	D	D1	t	L	M	L1	L2	D2	D3	H	h	库存
HSK A63 SHRB25-155-M42	1	25	45	10	155	42	87	-	53	-	45	127	○
-180-M67					180	67	87					147	●
-210-M67					210	67	117					187	●
-240-M67					240	67	147					217	●

HSK A63 整体式热胀刀柄(不锈钢材质)



图1

● 为常备库存 ○ 为少量库存

单位: mm

型号	D	D1	t	L	M	L1	L2	D2	D3	H	h	库存
HSK A63 SHSA4- 90 CV	4	7	1.5	90	64	-	-	-	-	13	70	○
-120 CV				120	94						95	●
-150 CV				150	124						127	●
-180 CV				180	154						157	●
-210 CV				210	184						187	
-240 CV				240	214						217	
-270 CV				270	244						245	
-300 CV				300	274						275	
HSK A63 SHRA4-120 CV				4	10	3	120	94	-		-	-
-150 CV	150	124								127	●	
-180 CV	180	154								157	●	
-210 CV	210	184								187	○	
HSK A63 SHSA6- 90 CV	6	9	1.5	90	64	-	-	-	-	19	70	○
-120 CV				120	94						95	●
-150 CV				150	124						127	●
-180 CV				180	154						157	●
-210 CV				210	184						187	○
-240 CV				240	214						217	

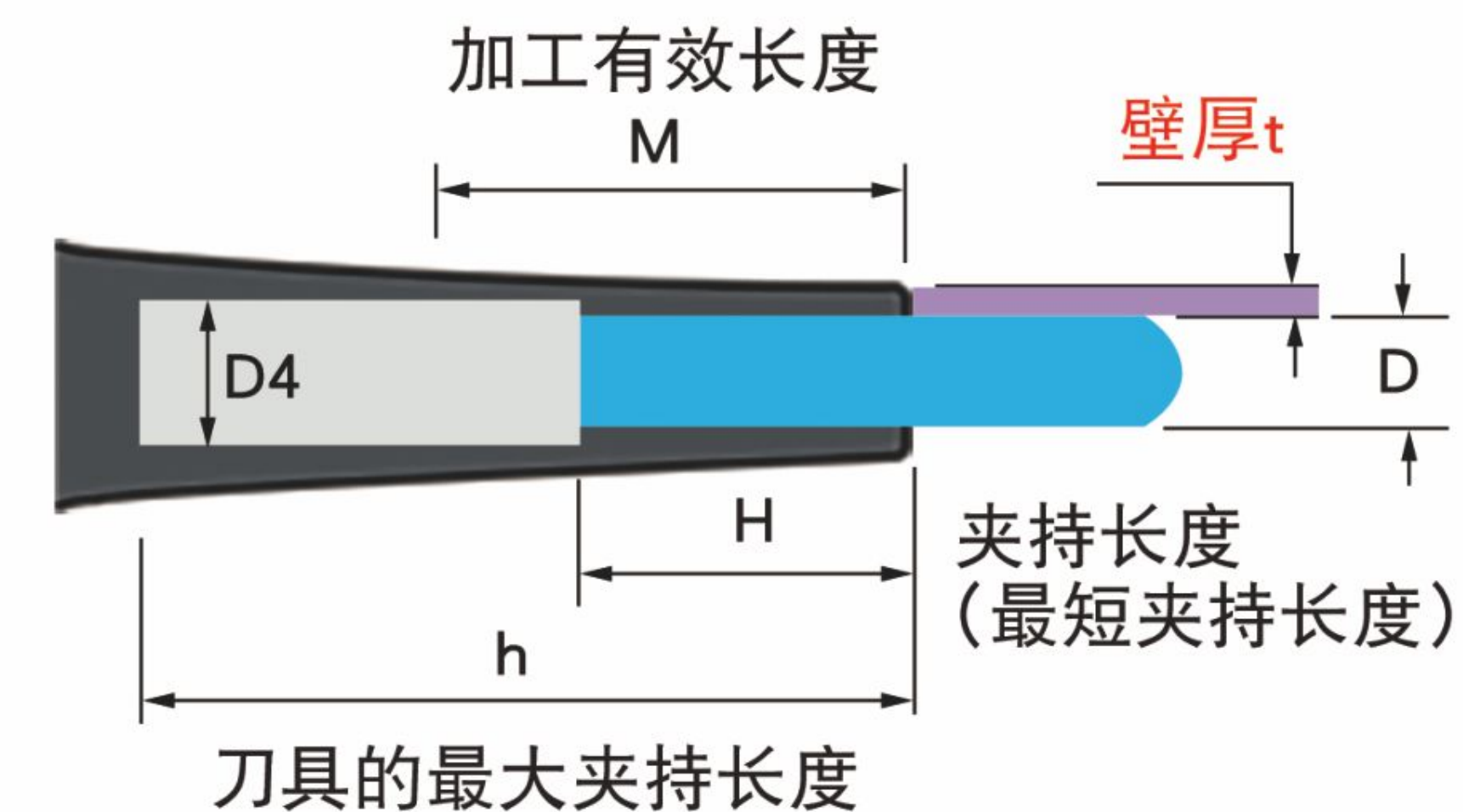
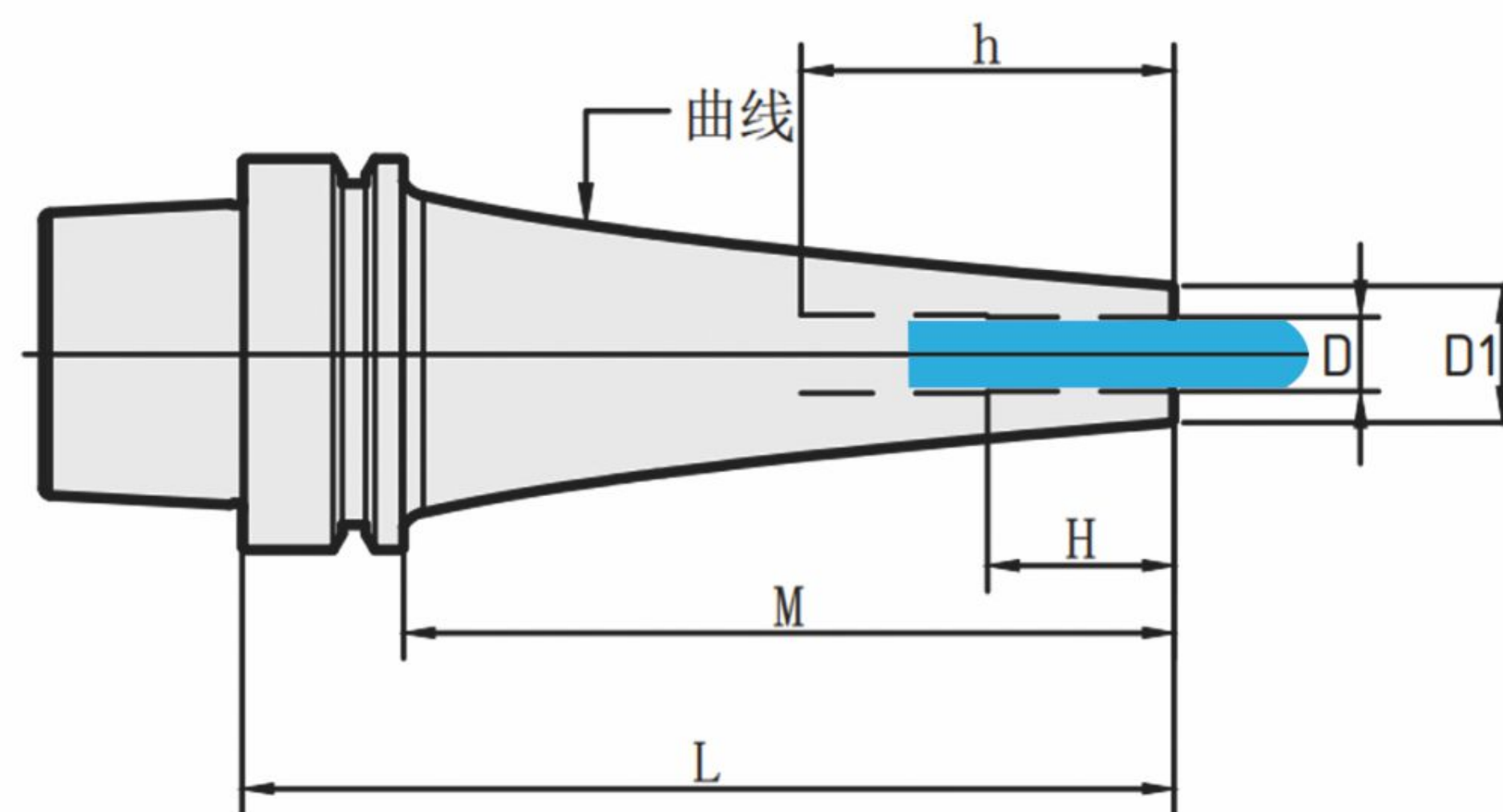
型号	D	D1	t	L	M	L1	L2	D2	D3	H	h	库存
HSK A63 SHSA6-270 CV	6	9	1.5	270	244	-	-	-	-	19	245	
-300 CV				300	274						275	
HSK A63 SHRA6- 90 CV	6	13	3.5	90	64	-	-	-	-	19	70	○
-120 CV				120	94						95	●
-150 CV				150	124						127	●
-180 CV				180	154						157	●
-210 CV				210	184						187	○
HSK A63 SHSA8- 90 CV	8	11	1.5	90	64	-	-	-	-	25	70	○
-120 CV				120	94						95	●
-150 CV				150	124						127	●
-180 CV				180	154						157	●
-210 CV				210	184						187	○
-240 CV				240	214						214	
-270 CV	270	244					245					
-300 CV	300	274					274					
HSK A63 SHRA8- 90 CV	8	16	4	90	64	-	-	-	-	25	70	○
-120 CV				120	94						95	●
-150 CV				150	124						127	●

HSK A63 整体式热胀刀柄(不锈钢材质)

型号	D	D1	t	L	M	L1	L2	D2	D3	H	h	库存
HSK A63 SHRA8-180 CV	8	16	4	180	154	-	-	-	-	25	157	●
-210 CV				210	184						185	○
HSK A63 SHSA10-90 CV	10	13	1.5	90	64	-	-	-	-	30	70	○
-120 CV				120	94						95	●
-150 CV				150	124						127	●
-180 CV				180	154						157	●
-210 CV				210	184						187	○
-240 CV				240	214						217	
-270 CV				270	244						245	
-300 CV				300	274						274	
HSK A63 SHRA10-90 CV				10	19	4.5	90	64	-		-	-
-120 CV	120	94								95	●	
-150 CV	150	124								125	●	
-180 CV	180	154								157	●	
-210 CV	210	184								185	○	
HSK A63 SHSA12-90 CV	12	15	1.5	90	64	-	-	-	-	30	70	○
-120 CV				120	94						94	●
-150 CV				150	124						125	●
-180 CV				180	154						157	●
-210 CV				210	184						187	○
-240 CV				240	214						217	
-270 CV	270	244					245					
HSK A63 SHRA12-90 CV	12	22	5	90	64	-	-	-	-	30	70	○
-120 CV				120	94						95	●
-150 CV				150	124						127	●
-180 CV				180	154						157	●
-210 CV				210	184						187	○
HSK A63 SHSB16-90 CV	16	21	2.5	90	64	-	-	-	-	32	70	
-120 CV				120	94						95	
-150 CV				150	124						127	
-180 CV				180	154						157	
-210 CV				210	184						187	
-240 CV				240	214						217	
-270 CV				270	244						245	
HSK A63 SHSB20-90 CV	20	26	3	90	64	-	-	-	-	40	70	
-120 CV				120	94						95	
-150 CV				150	124						127	

型号	D	D1	t	L	M	L1	L2	D2	D3	H	h	库存
-180 CV	20	26	3	180	154	-	-	-	-	40	157	
-210 CV				210	184						187	
-240 CV				240	214						217	
-270 CV				270	244						245	

HSK A100 整体式热胀刀柄(不锈钢材质)



图1



图2

● 为常备库存 ○ 为少量库存

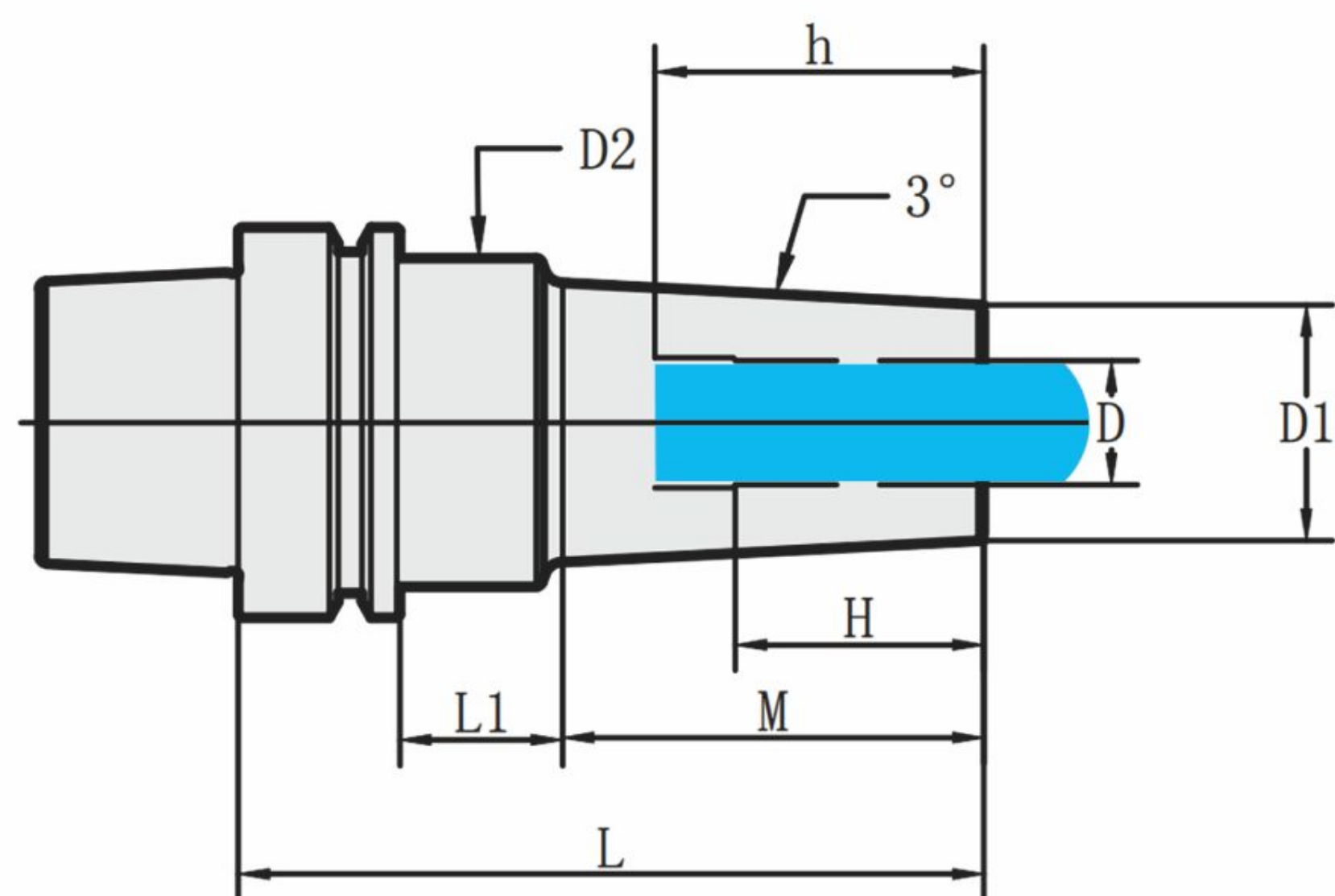
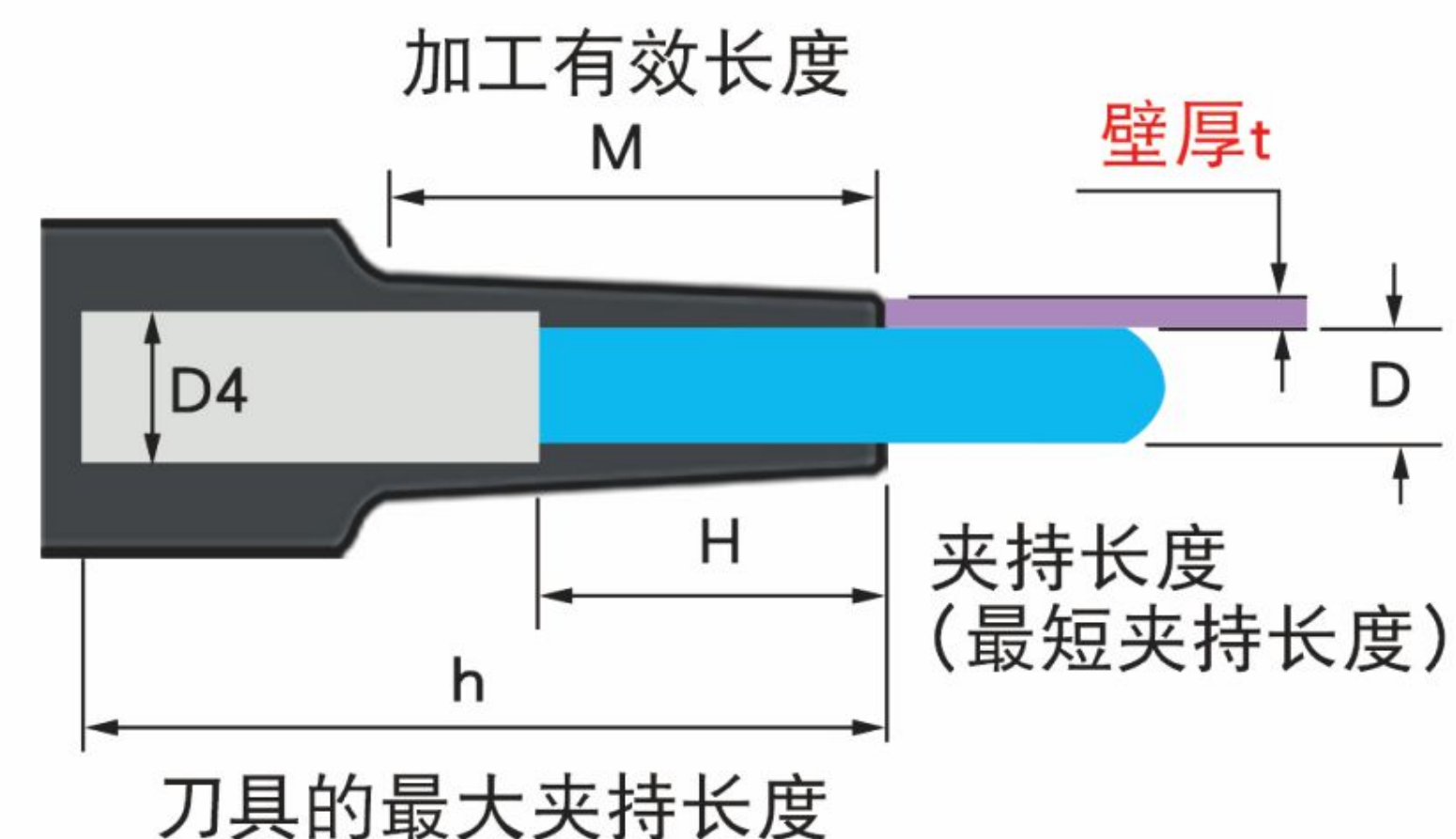
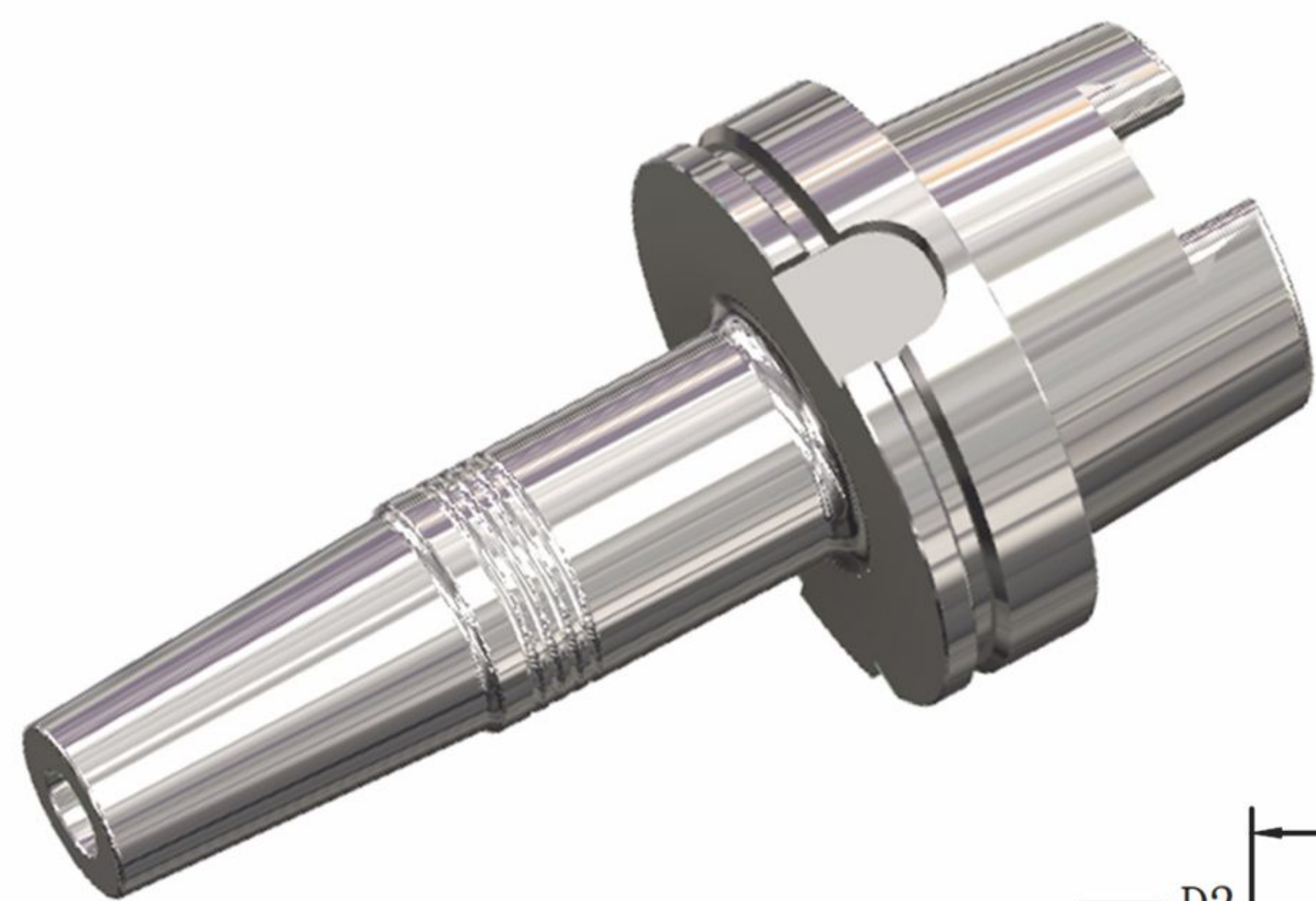
单位: mm

型号	图	D	D1	t	L	M	L1	L2	D2	D3	H	h	库存	
HSK A100 SHSA4-110-M 42	1	4	7	1.5	110	42	39	-	26	-	12	80	○	
-135-M 67					135	67							105	○
-140-M 42					140	42	69		25				110	○
-165-M 67					165	67			26				135	○
-165-M 97					97	39								○
-170-M 42	2				170	42	33	66		40			140	○
-195-M 67					195	67			25	39			165	○
-195-M 97	1				97	69	-			-				○
-225-M 97	2				225	97	33	66		39			195	○
HSK A100 SHRA4-90-M 22	1	4	10		3	90	22	39	-	26	-	12	60	○
-110-M 42				110		42							80	●

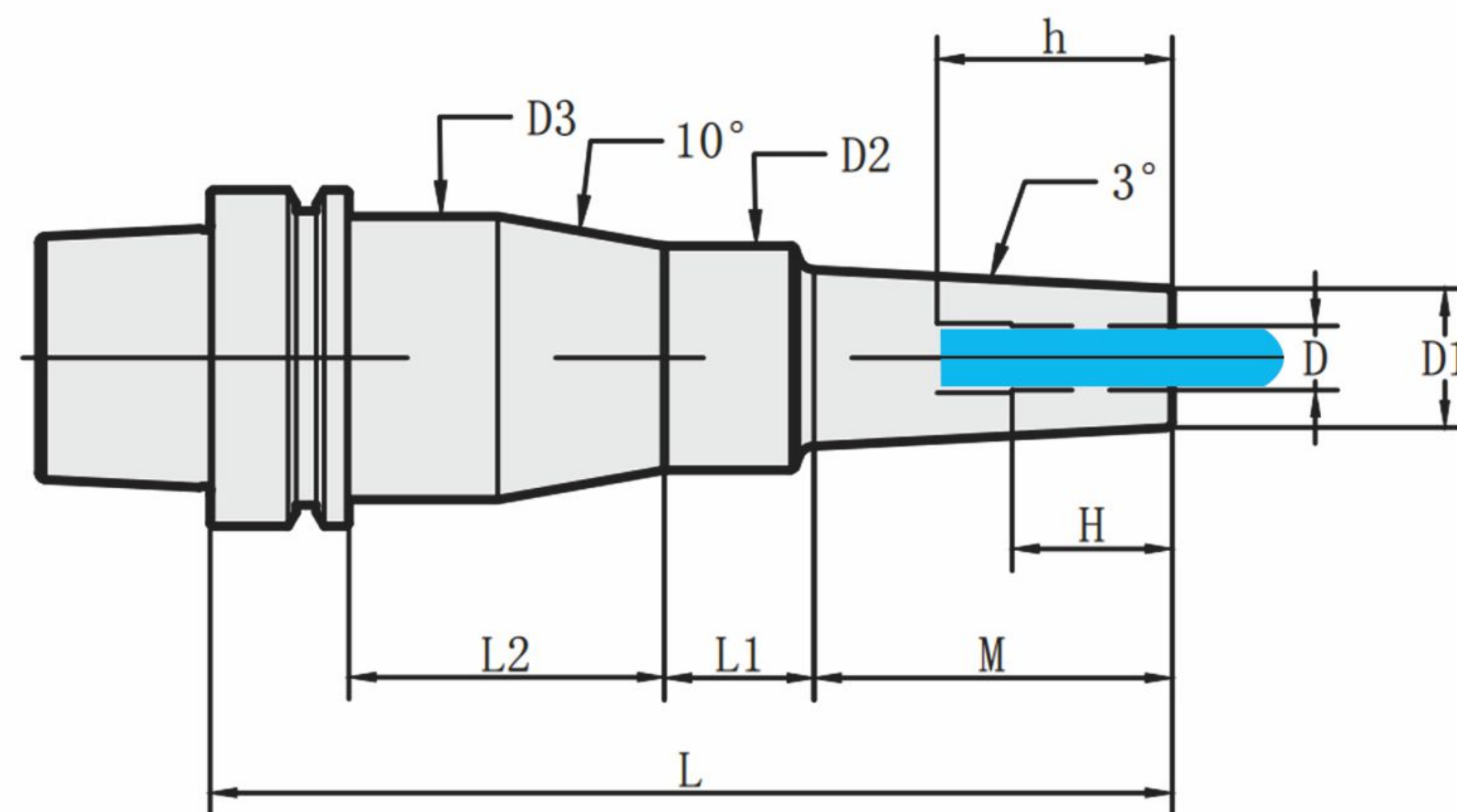
型号	图	D	D1	t	L	M	L1	L2	D2	D3	H	h	库存	
HSK A100 SHRA4-120-M 22	1	4	10	3	120	22	69	-	26	-	12	90		
-135-M 67					135	67	39						105	●
-140-M 42					140	42	69						110	○
-150-M 22	2				150	22	33	66		40			120	
-165-M 67	1				165	67	69	-		-			135	●
-165-M 97					97	39								○
-170-M 42	2				170	42	33	66		40			140	○
-195-M 67					195	67			25	39			165	○
-195-M 97	1				97	69	-		26	-				●
-195-M127					127	39			32					○
-225-M 97	2			225	97	33	66	26	40			195		

HSK A100 整体式热胀刀柄(不锈钢材质)

型号	图	D	D1	t	L	M	L1	L2	D2	D3	H	h	库存	
HSK A100 SHRA4-225-M127	1	4	10	3	225	127	69	-	36	-	12	195	○	
-255-M127	2				255	127	29	71			50		225	
HSK A100 SHSA6-110-M 42	1	6	9	1.5	110	42	39	-	25	-	18	80	○	
-135-M 67					135	67							105	○
-140-M 42					140	42	69						110	○
-165-M 67					165	67							135	○
-165-M 97						97	39		36					○
-170-M 42	2				170	42	33	66	25	39			140	○
-195-M 67					195	67			26	40			165	○
-195-M 97	1					97	69	-	36	-				○
-225-M 97	2				225	97	30	69	32	46			195	○
HSK A100 SHSB6-110-M 42	1	6	10		2	110	42	39	-	26	-	18	80	○
-135-M 67				135		67							105	●
-140-M 42				140		42	69						110	○
-165-M 67				165		67							135	●
-165-M 97						97	39		36					○
-170-M 42	2			170		42	33	66	26	40			140	○
-195-M 67				195		67							165	
-195-M 97	1					97	69	-	36	-				●
-195-M127						127	39							○
-225-M 97	2			225		97	28	71		50			195	
-225-M127	1					127	69	-	32	-				○
-225-M157						157	39							○
-255-M127	2			255		127	28	71	36	50			225	
-255-M157	1					157	69	-	32	-				
-285-M157	2			285	157	30	69		46			255		
HSK A100 SHRB6- 90-M 22	1	6	14	4	90	22	39	-	32	-	18	60	○	
-110-M 42					110	42							80	●
-120-M 22					120	22	69		36				90	
-135-M 67					135	67	39		32				105	●
-140-M 42					140	42	69						110	○
-150-M 22	2				150	22	30	69		46			120	
-165-M 67	1				165	67	69	-	36	-			135	●
-170-M 42	2				170	42	28	71		50			140	○
-195-M 67					195	67							165	○
HSK A100 SHSA8-110-M 42	1	8	11	1.5	110	42	39	-	36	-	24	80		
-135-M 67					135	67				32			105	○

型号	图	D	D1	t	L	M	L1	L2	D2	D3	H	h	库存	
HSK A100 SHSA8-140-M 42	1	8	11	1.5	140	42	69	-	36	-	24	110	○	
-165-M 67					165	67							135	○
-165-M 97						97	39							○
-170-M 42	2				170	42	28	71			50		140	○
-195-M 67					195	67				36			165	○
-195-M 97	1					97	69	-	32	-				○
-225-M 97	2				225	97	28	71	36	50			195	○
HSK A100 SHSB8-110-M 42	1	8	13		2.5	110	42	39	-	36	-	24	80	○
-135-M 67				135		67							105	●
-140-M 42				140		42	69			32			110	
-165-M 67				165		67							135	●
-165-M 97						97	39							○
-170-M 42	2			170		42	28	71	36	50			140	
-195-M 67				195		67	30	69	32	46			165	
-195-M 97	1					97	69	-		-				●
-195-M127						127	39		36					○
-225-M 97	2			225		97	30	69	32	46			195	
-225-M127	1					127	69	-	36	-				○
-225-M157						157	39		42					○
-255-M127	2			255	127	30	69	32	46			225		
-255-M157	1				157	69	-	42	-					
-285-M157	2			285	157	28	71		56			255		
HSK A100 SHRB8 - 90-M 22	1	8	18	5	90	22	39	-	32	-	24	60	○	
-110-M 42					110	42				36			80	●
-120-M 22					120	22	69			32			90	
-135-M 67					135	67	39						105	●
-140-M 42					140	42	69						110	○
-150-M 22	2				150	22	30	69		46			120	
-165-M 67	1				165	67	69	-	36	-			135	●
-170-M 42	2			170	42	28	71		46			140	○	
-195-M 67				195	67							165	○	
HSK A100 SHSA10-110-M 42	1	10	13	1.5	110	42	39	-	25	-	30	80		
-135-M 67					135	67				36			105	○
-145-M 42					145	42	69			25			110	○
-165-M 67					165	67				36			135	○
-165-M 97						97	39							○
-170-M 42	2				170	42	28	71		50			140	○

HSK A100 整体式热胀刀柄(不锈钢材质)

型号	图	D	D1	t	L	M	L1	L2	D2	D3	H	h	库存	
HSK A100 SHSA10-195-M67	2	10	13	1.5	195	67	28	71	36	50	30	165	○	
-195-M 97	1					97	69	-		-			○	
-225-M 97	2					225	97	30	69	32	46		195	○
HSK A100 SHSB10-110-M 42	1	10	16	3	110	42	39	-	36	-	30	80	○	
-135-M 67						135	67						105	●
-140-M 42						140	42	69		32			110	
-165-M 67						165	67						135	●
-165-M 97							97	39		36				○
-170-M 42	2					170	42	28	71		50		140	
-195-M 67						195	67						165	
-195-M 97	1						97	69	-		-			●
-195-M127							127	39		42				○
-225-M 97	2					225	97	30	69	32	46		195	
-225-M127	1						127	69	-	50	-			○
-225-M157							157	39		42				○
-255-M127						255	127	99		50			225	
-255-M157							157	69		42				
-285-M157						285	157	99		50			255	
HSK A100 SHRB10- 90-M 22	1	10	22		6	90	22	39	-	36	-	30	60	○
-110-M 42							110	42						80
-120-M 22						120	22	69					90	
-135-M 67						135	67	39		42			105	●
-140-M 42						140	42	69		32			110	○
-150-M 22	2					150	22	28	71	36	50		120	
-165-M 67	1					165	67	69	-		-		135	●
-170-M 42	2					170	42	28	71		50		140	○
-195-M 67						195	67						165	○
HSK A100 SHSA12-110-M 42	1	12	15	1.5		110	42	39	-	32	-	30	79	
-135-M 67						135	67						105	○
-140-M 42						140	42	69					110	○
-165-M 67						165	67						130	○
-165-M 97							97	39		36			134	○
-170-M 42	2					170	42	28	71		50		135	○
-195-M 67						195	67	30	69	32	46		160	○
-195-M 97	1					195	97	69	-	36	-			○
-225-M 97	2					225	97	28	71		50		190	○
HSK A100 SHSB12-110-M 42	1	12	19		3.5	110	42	39	-	36	-	30	79	○

型号	图	D	D1	t	L	M	L1	L2	D2	D3	H	h	库存		
HSK A100 SHSB12-135-M 67	1	12	19	3.5	135	67	39	-	32	-	30	104	●		
-140-M 42						140	42	69					105		
-165-M 67						165	67			36			130	●	
-165-M 97							97	39		50				○	
-170-M 42	2					170	42	28	71	36	50		135		
-195-M 67						195	67						160		
-195-M 97	1						97	69	-	50	-			●	
-195-M127							127	39						○	
-225-M 97						225	97	99					190		
-225-M127							127	69		42				○	
-225-M157							157	39		50				○	
-255-M127						255	127	99					220		
-255-M157							157	69		42					
-285-M157						285	157	99		50			250		
HSK A100 SHRB12 - 90-M 22	1	12	26		7	90	22	39	-	50	-	30	55	○	
-110-M 42							110	42			42			75	●
-120-M 22							120	22	69					85	
-135-M 67						135	67	39		50			100	●	
-140-M 42						140	42	69		42			105	○	
-150-M 22						150	22	99		50			115		
-165-M 67						165	67	69		42			130	●	
-170-M 42						170	42	99		50			135	○	
-195-M 67						195	67						160	○	
HSK A100 SHSB16 -110-M 42	1	16	24	4		110	42	39	-	50	-	32	75	○	
-135-M 67						135	67						100	●	
-140-M 42						140	42	69					105		
-165-M 67						165	67			42			130	●	
-165-M 97							97	39		50				○	
-170-M 42						170	42	99					135		
-195-M 67						195	67		59				160		
-195-M 97							97	69	-	42				●	
-195-M127							127	39		50				○	
-225-M 97						225	97	99	-				190		
-225-M127							127	69						○	
-225-M157							157	39		53				○	
-255-M127	2					255	127	28	71		67		220		
-255-M157	1						157	69	-	50	-				

HSK A100 整体式热胀刀柄(不锈钢材质)

型号	图	D	D1	t	L	M	L1	L2	D2	D3	H	h	库存	
HSK A100 SHSB16-285-M157	1	16	24	4	285	157	28	71	53	67	32	250		
HSK A100 SHRB16- 90-M 22	1	16	32	8	90	22	39	-	42	-	32	55	○	
-110-M 42					110	42						75	●	
-120-M 22					120	22	69					85	●	
-135-M 67					135	67	39			50		100	●	
-140-M 42					140	42	69					105	○	
-150-M 22					150	22	99					115		
-165-M 67					165	67	69			42		130		
-170-M 42					170	42	99			50		135	○	
-195-M 67					195	67						160	●	
HSK A100 SHSB20-110-M 42	1	20	29		4.5	110	42	39	-	50	-	40	75	●
-135-M 67				135		67				42		100	●	
-140-M 42				140		42	69			50		105		
-165-M 67				165		67						130	○	
-165-M 97						97	39			53			○	
-170-M 42	2			170		42	28	71	42	56		135	○	
-195-M 67	1			195		67	99	-	50	-		160	○	
-195-M 97						97	69						○	
-195-M127						127	39			53			○	
-225-M 97				225		97	99			50		190	○	
-225-M127						127	69							
-225-M157						157	39			53				
-255-M127				255		127	99			50		220		
-255-M157						157	69							
-285-M157	2			285		157	28	71	53	67		250		
HSK A100 SHRB20-110-M 42	1	20	38	9		110	42	39	-	53	-	40	75	
-135-M 67						135	67						100	
-140-M 42						140	42	69					105	●
-165-M 67						165	67						130	●
-170-M 42					170	42	99			50		135	○	
-195-M 67	2				195	67	28	71	53	67		160		
HSK A100 SHRB25-110-M 42	1	25	45	10	110	42	39	-	50	-	45	75	○	
-140-M 42					140	42	69					105	●	
-170-M 42	2				170	42	28	71	53	67		135	●	

HSK A100 整体式热胀刀柄(不锈钢材质)

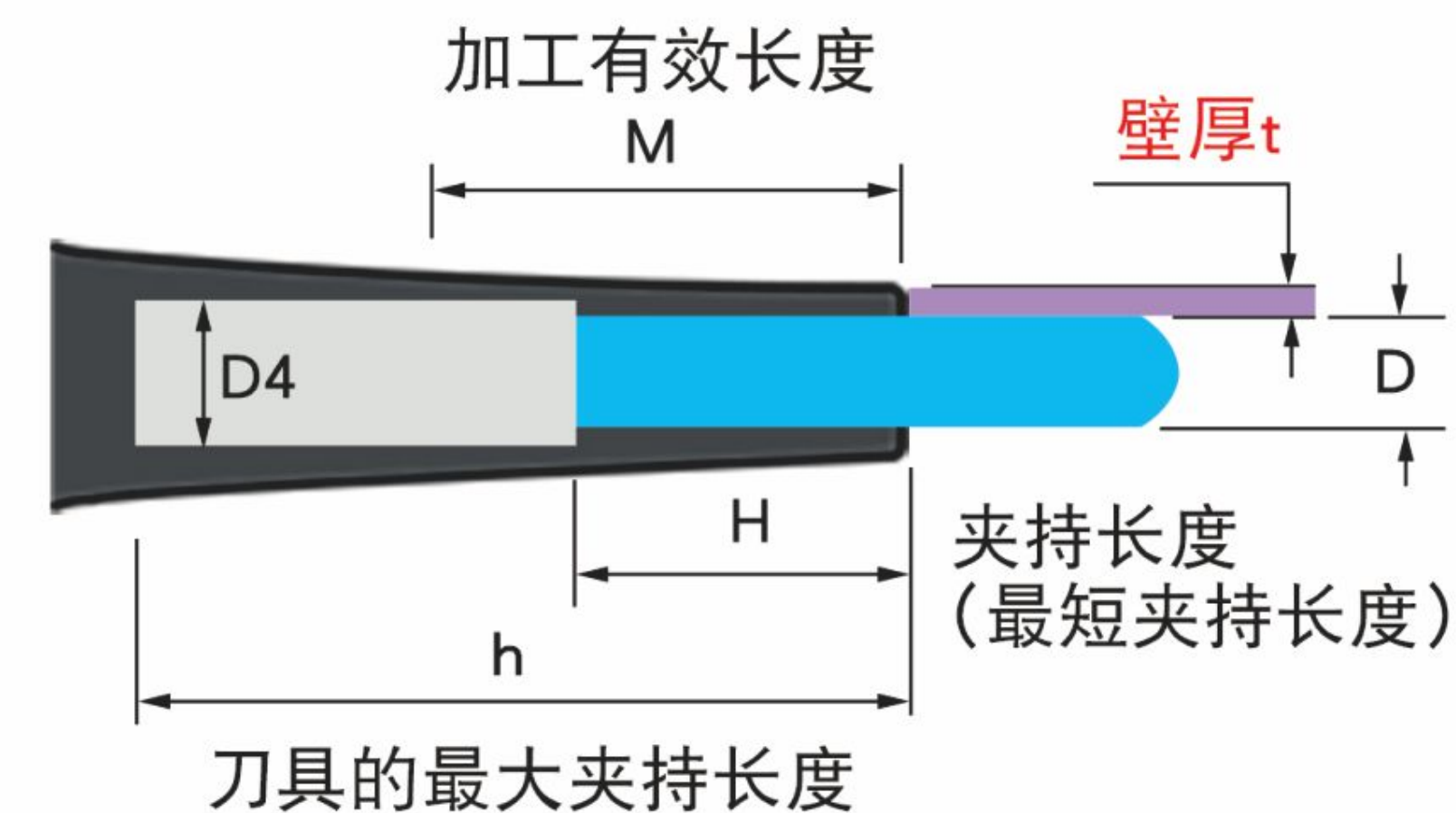
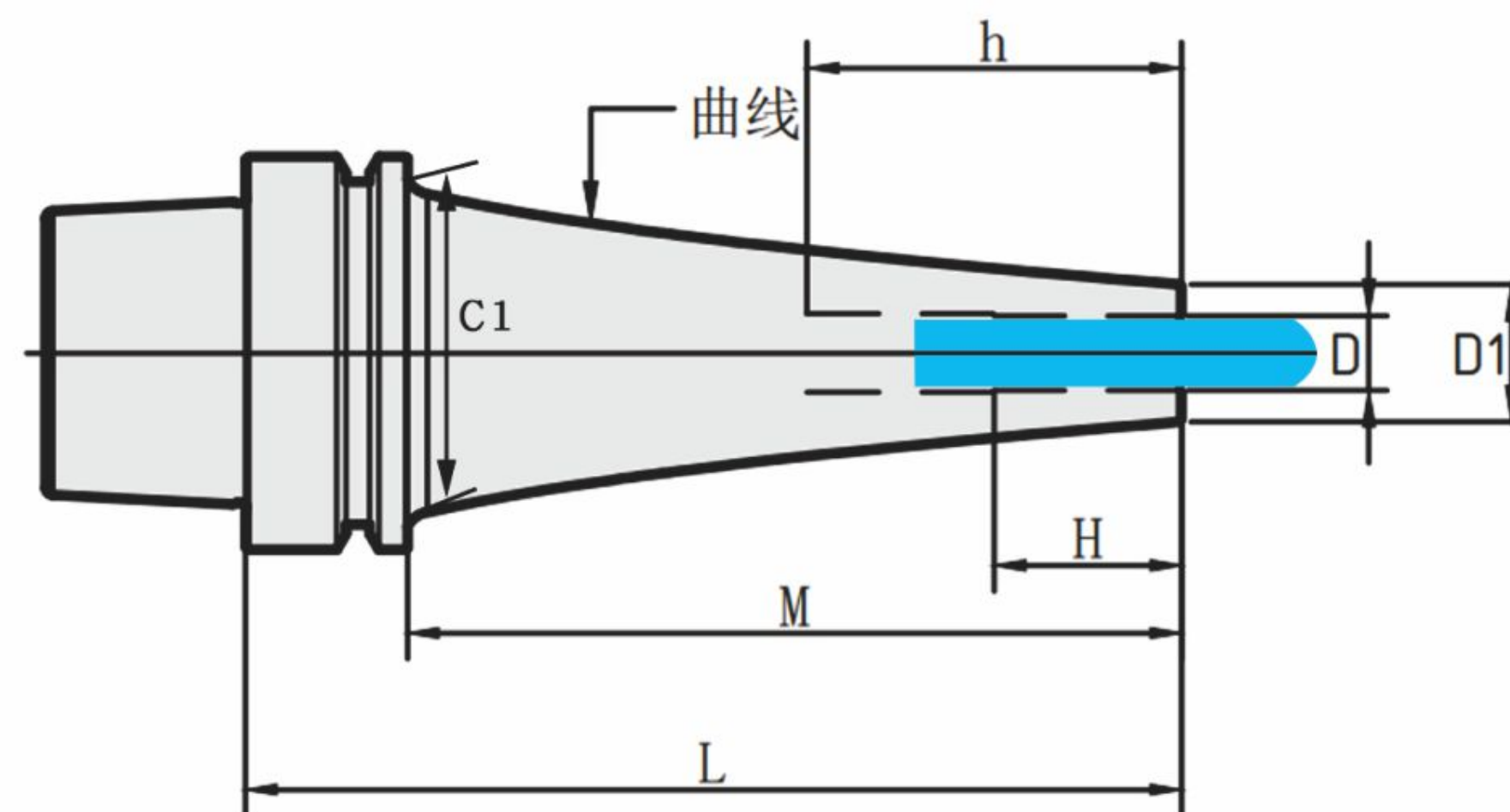

● 为常备库存 ○ 为少量库存

单位: mm

型号	D	D1	t	L	M	L1	L2	C1	D4	H	h	库存
HSK A100 SHSA4-165 CV	4	7	1.5	165	136	-	-	85	5	13	133	○
-195 CV				195	166	●						
-225 CV				225	196	●						
-255 CV				255	226	●						
-285 CV				285	256							
-315 CV				315	286							
-345 CV				345	316							
HSK A100 SHSA6-165 CV				6	9	1.5	165				136	-
-195 CV	195	166	●									
-225 CV	225	196	●									
-255 CV	255	226	●									
-285 CV	285	256	○									
-315 CV	315	286	○									
-345 CV	345	316	●									
HSK A100 SHSA8-165 CV	8	11	1.5				165	136	-	-	85	9
-195 CV				195	166	●						
-225 CV				225	196	○						
-255 CV				255	226							

型号	D	D1	t	L	M	L1	L2	C1	D4	H	h	库存
HSK A100 SHSA8-285 CV	8	11	1.5	285	256	-	-	85	9	24	256	
-315 CV				315	286							
-345 CV				345	316							
HSK A100 SHRA8-195 CV				8	16	4	195				166	-
-225 CV	225	196	●									
-255 CV	255	226	●									
-285 CV	285	256	○									
HSK A100 SHSA10-165 CV	10	13	1.5	165	136	-	-	85	11	30	136	○
-195 CV				195	166	●						
-225 CV				225	196	●						
-255 CV				255	226	●						
-285 CV				285	256	○						
-315 CV				315	286							
-345 CV				345	316							
HSK A100 SHRA10-165 CV				10	19	4	165				136	-
-195 CV	195	166	○									
-225 CV	225	196	●									
-255 CV	255	226	●									

HSK A100 整体式热胀刀柄(不锈钢材质)

型号	D	D1	t	L	M	L1	L2	C1	D4	H	h	库存
HSK A100 SHRA10-285 CV	10	19	4.5	285	256	-	-	85	11	30	256	●
HSK A100 SHSA12-165 CV	12	15	1.5	165	136	-	-	85	13	30	133	○
-195 CV				195	166						163	○
-225 CV				225	196						175	●
-255 CV				255	226						190	●
-285 CV				285	256						251	●
-315 CV				315	286						281	○
-345 CV				345	316						311	
HSK A100 SHRA12-165 CV				12	22						5	165
-195 CV	195	166	14			163						
-225 CV	225	196	13			159	○					
-255 CV	255	226				221	●					
-285 CV	285	256				251	●					
HSK A100 SHSB16-165 CV	16	21	2.5			165	136	-	-	85		17
-195 CV				195	166	161	○					
-225 CV				225	196	191	○					
-255 CV				255	226	221	●					
-285 CV				285	256	251	●					
-315 CV				315	286	281	●					
-345 CV				345	316	311	○					
HSK A100 SHSB20-165 CV				20	26	3	165				136	
-195 CV	195	166	161									
-225 CV	225	196	191				○					
-255 CV	255	226	221				●					
-285 CV	285	256	251				●					
-315 CV	315	286	281				●					
-345 CV	345	316	311				○					

HSK E32 整体式热胀刀柄(不锈钢材质)

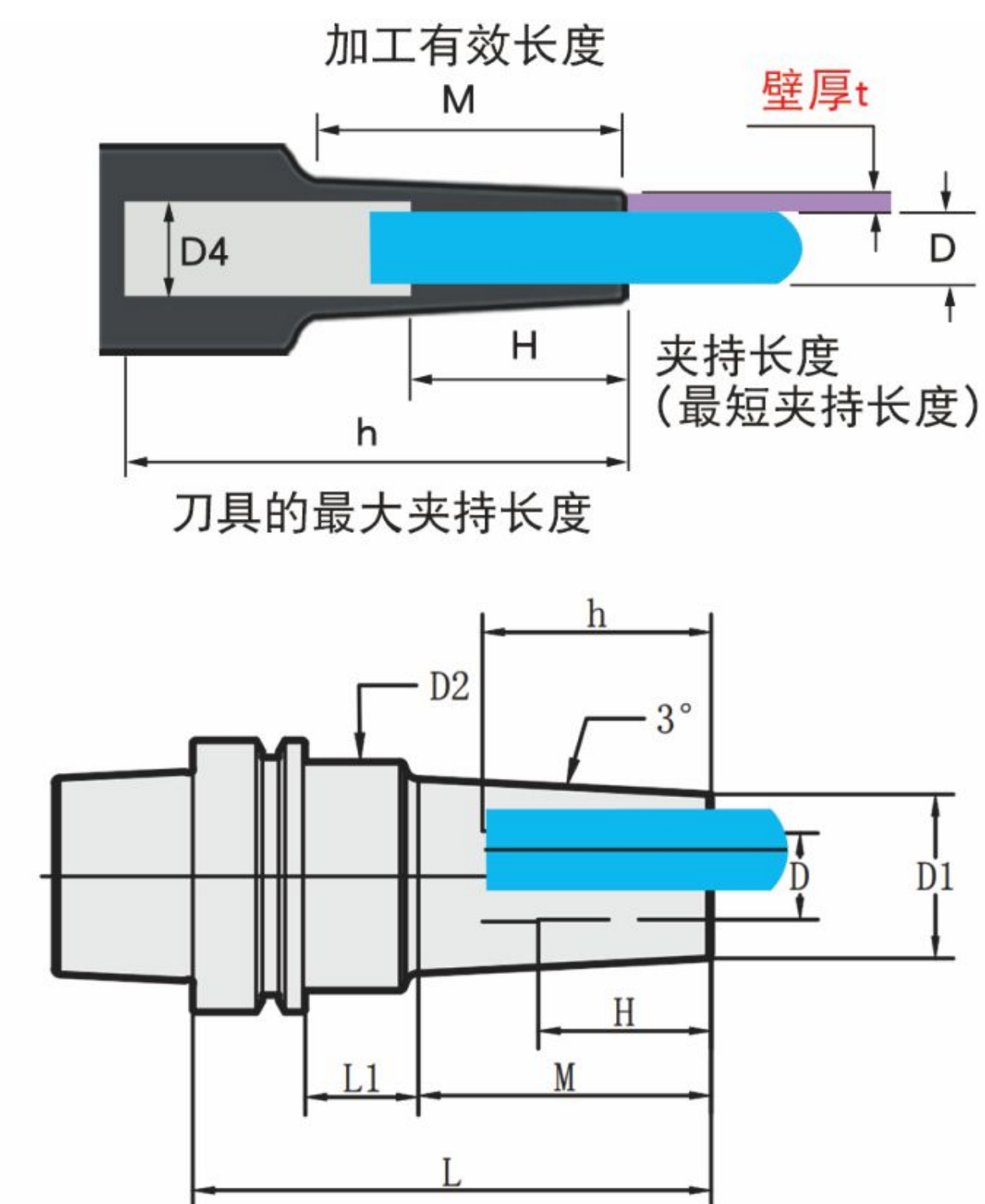
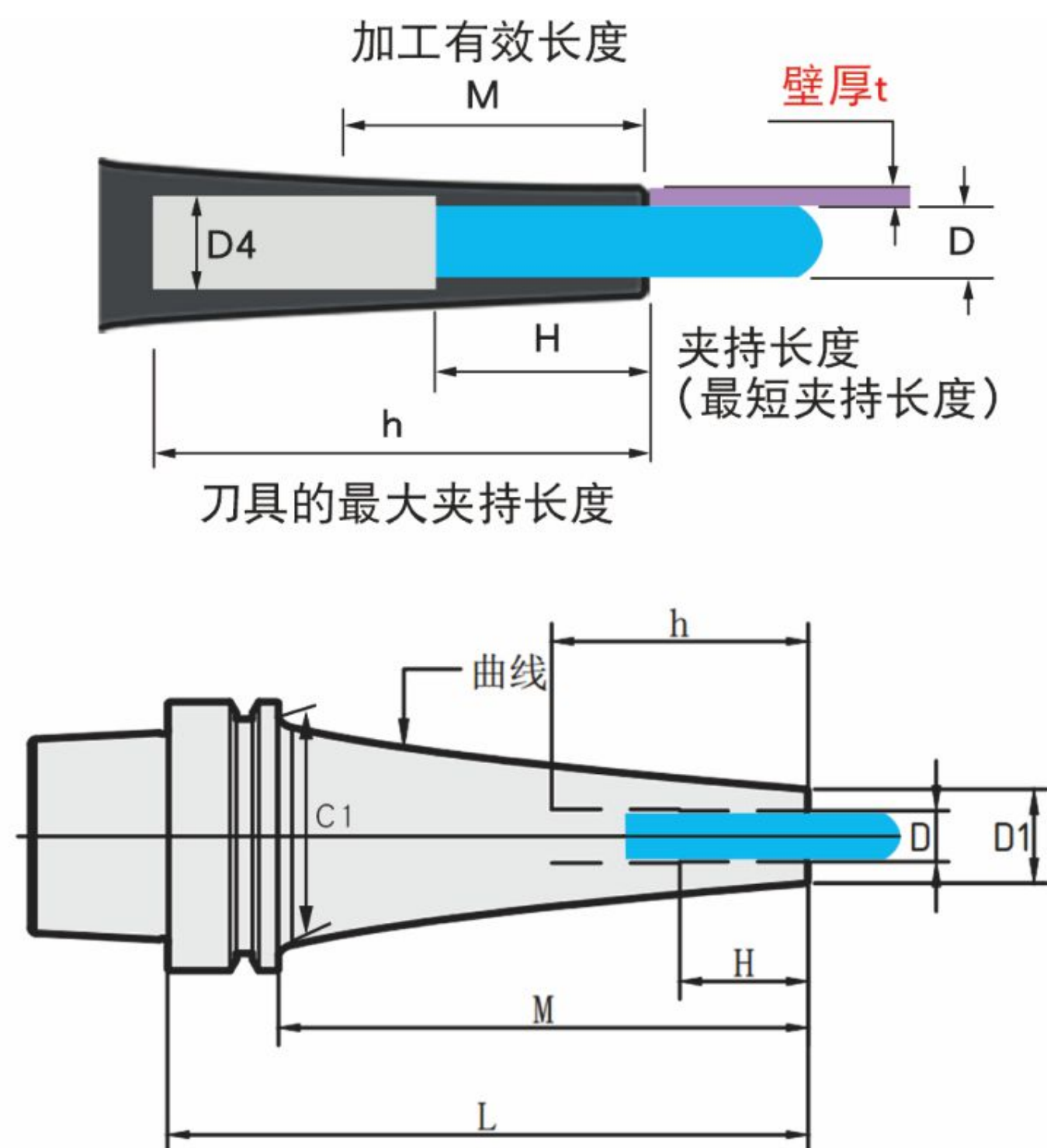

● 为常备库存 ○ 为少量库存

型号	D	D1	t	L	M	C1	D4	D2	D3	H	h	库存
HSK E32 SHSA4- 60 CV	4	7	1.5	60	40	26	5	-	-	13	43	●
- 90 CV				90	70						73	●
HSK E32 SHSA6- 60 CV	6	9	3	60	40	26	7	-	-	18	43	●
- 90 CV				90	70						73	●
HSK E32 SHSA8- 60 CV	8	11	1.5	60	40	26	8.6	-	-	24	38	●
- 90 CV				90	70						38	●
HSK E32 SHSA10- 60 CV	10	13	1.5	60	40	26	10.6	-	-	30	48	●
- 90 CV				90	70						60	●

● 为常备库存 ○ 为少量库存

型号	D	D1	t	L	M	L1	D4	D2	D3	H	h	库存
HSK E32 SHSA4- 50-M 22	4	7	1.5	50	22	8	5	20	9.3	13	35	●
- 70-M 42				70	42				11.4		54	●
- 85-M 42				85	42	23		25			69	●
HSK E32 SHRA4- 50-M 22	4	10	3	50	22	8	5	20	12.3	13	35	●
- 70-M 42				70	42				14.4		54	●
- 85-M 42				85	42	23		25			69	●
HSK E32 SHSA6- 70-M 42	6	9	1.5	70	42	8	7	20	13.4	18	54	●
HSK E32 SHRA6- 50-M 22	6	12	3	50	22		6.6	26	14.3	18	39	●
- 70-M 42				70	42		7		16.4		54	●
- 85-M 42				85	42	23		25			69	●
HSK E32 SHRA8- 50-M 22	8	14	3	50	22	8	8.6	26	16.3	20	39	●
- 85-M 42				85	42	23	9	25	18.4	24	49	●
HSK E32 SHRA10- 55-M 22	10	16	3	55	22	13	10.6	26	18.3	25	44	●
HSK E32 SHRA12- 55-M 22	12	20	4	55	22	13	12.6	26	22.3	25	44	●
HSK E32 SHRA16- 55-M 35	16	26	5	55	35	-	16.6	-	-	32	44	●

HSK E40 整体式热胀刀柄(不锈钢材质)

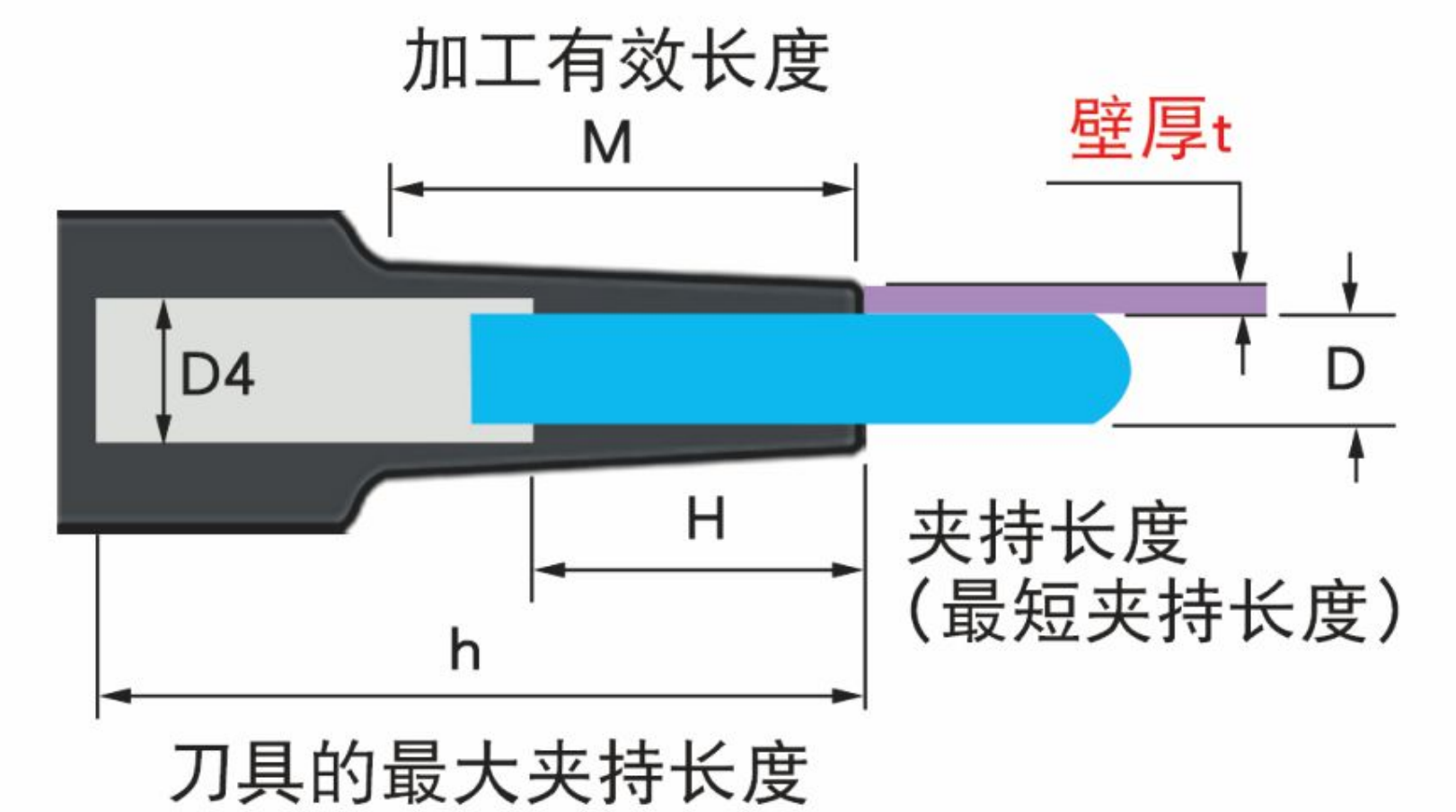
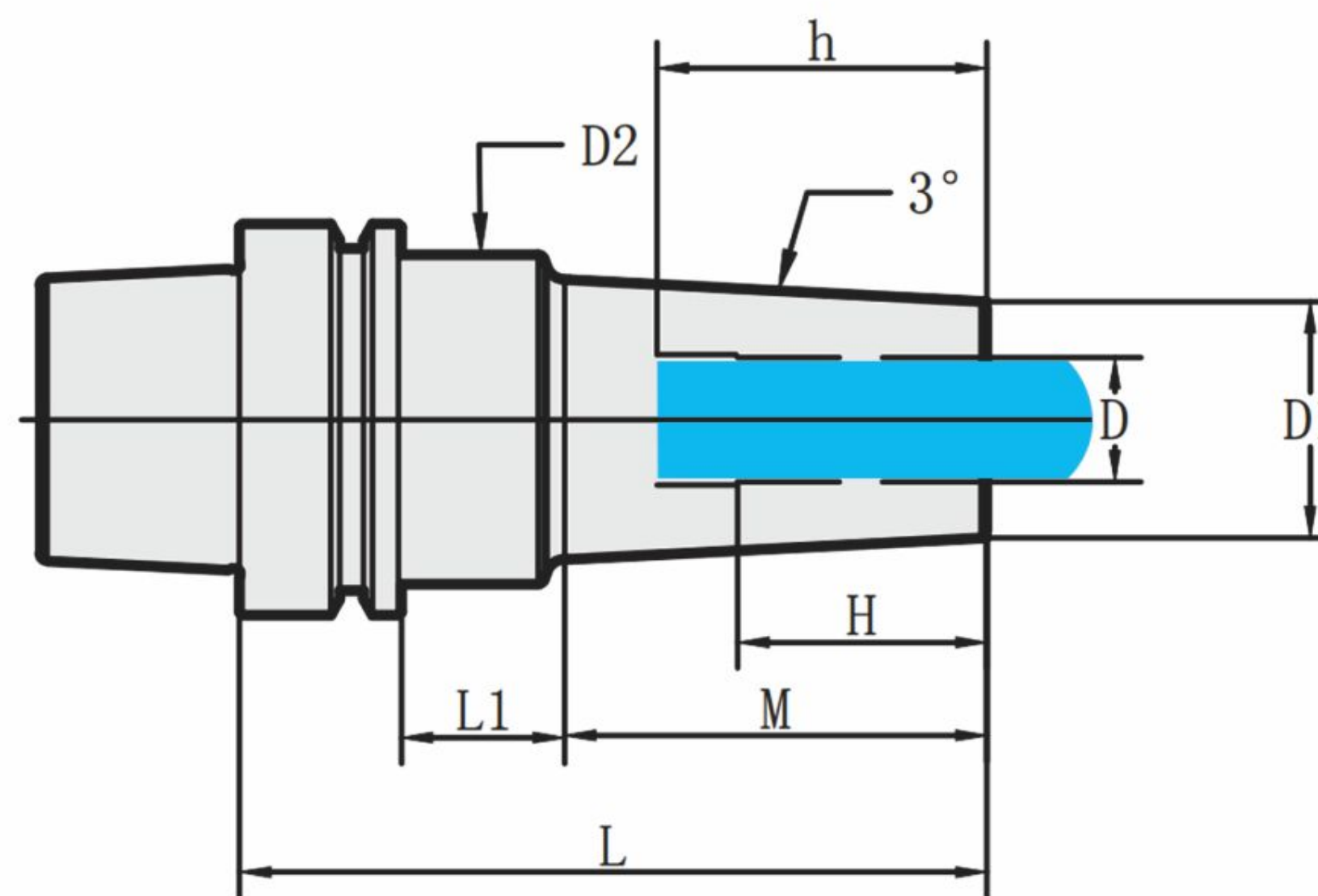

● 为常备库存 ○ 为少量库存

单位: mm

型号	D	D1	t	L	M	L1	D4	D2	D3	H	h	库存
HSK E40 SHSA4- 50-M 22	4	7	1.5	50	22	8	5	20	9.3	13	42	○
- 70-M 42				70	42				11.4		62	●
- 85-M 42				85	42	23					74	●
- 110-M 67				110	67				14		99	●
HSK E40 SHRA4- 50-M 22	4	10	3	50	22	8	5	20	12.3	13	42	
- 70-M 42				70	42				14.4		62	
- 85-M 42				85	42	23					69	
- 110-M 67				110	67				17		94	
HSK E40 SHSA6- 50-M 22	6	9	1.5	50	22	8	6.6	20	11.3	18	39	●
- 70-M 42				70	42		7		13.4		54	●
- 85-M 42				85	42	23			69		●	
- 110-M 67				110	67		16		94		○	
HSK E40 SHRA6- 50-M 22	6	12	3	50	22	8	6.6	26	14.3	18	39	○
- 70-M 42				70	42				16.4		54	●
- 85-M 42				85	42	23	7		25		69	●
- 110-M 67				110	67				19		94	●
HSK E40 SHSA8- 60-M 22	8	11	1.5	60	22	18	8.6	26	13.3	24	49	○
- 80-M 42				80	42						15.4	64

型号	D	D1	t	L	M	L1	D4	D2	D3	H	h	库存		
HSK E40 SHSA8-100-M 42	8	11	1.5	100	42	38	9	25	15.4	24	84			
HSK E40 SHRA8- 50-M 22	8	14	3	50	22	8	8.6	26	16.3	20	39			
- 85-M 42				85	42	23	9		25		18.4	24	69	○
- 100-M 42				100	42	38					84	●		
HSK E40 SHSA10- 60-M 22	10	13	1.5	60	22	18	10.6	26	15.3	30	49	●		
- 85-M 42				80	42				17.4		64	●		
- 100-M 42				110	42	38	11		25		89	○		
HSK E40 SHRA10- 55-M 22	10	16	3	55	22	13	10.6	26	18.3	25	44	○		
- 85-M 42				85	42	23	11		25		20.4	30	64	●
- 100-M 42				100	42	38					64	●		
HSK E40 SHRA12- 55-M 22	12	20	4	55	22	13	12.6	30	22.3	25	44	●		
- 85-M 42				85	42	23	13		32		24.4	30	74	○
HSK E40 SHRA16- 55-M 22	16	26	5	55	22	13	16.6	34	28.3	32	44			
HSK E40 SHRA20- 60-M 40	20	32	6	60	40	-	20.6	-	34	38	49			

HSK E40 整体式热胀刀柄(不锈钢材质)



图1

● 为常备库存 ○ 为少量库存

单位: mm

型号	D	D1	t	L	M	L1	L2	C1	D4	H	h	库存
HSK E40 SHSA4- 90 CV	4	7	1.5	90	70	-	-	34	5	13	74	○
-120 CV				120	100	104	●					
-150 CV				150	130	134	●					
HSK E40 SHRA4- 90 CV	4	10	3	90	70	-	-	34	5	13	81	●
-120 CV				120	100	111						
HSK E40 SHSA6- 90 CV	6	9	1.5	90	70	-	-	34	7	18	74	
-120 CV				120	100	104						
-150 CV				150	130	134						
HSK E40 SHRA6- 90 CV	6	13	3.5	90	70	-	-	34	7	18	74	●
-120 CV				120	100	104	●					
HSK E40 SHSA8- 90 CV	8	11	1.5	90	70	-	-	34	9	24	74	●
-120 CV				120	100	104	○					
-150 CV				150	130	134	○					
HSK E40 SHRA8- 90 CV	8	16	4	90	70	-	-	34	9	24	74	●
-120 CV				120	100	104	●					
HSK E40 SHSA10- 90 CV	10	19	1.5	90	70	-	-	34	9	30	74	●
-120 CV				120	100	104	○					
-150 CV				150	130	134						

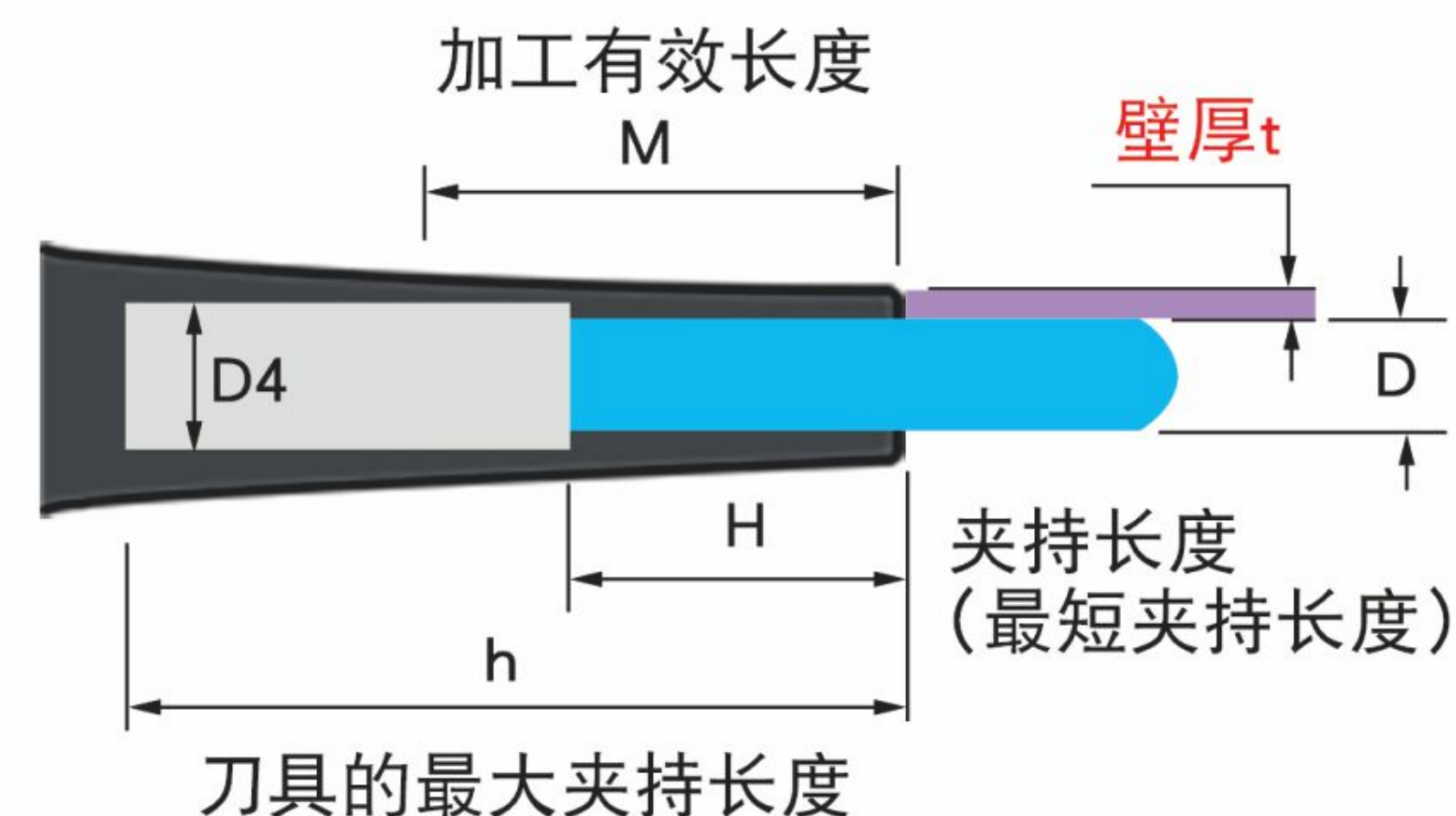
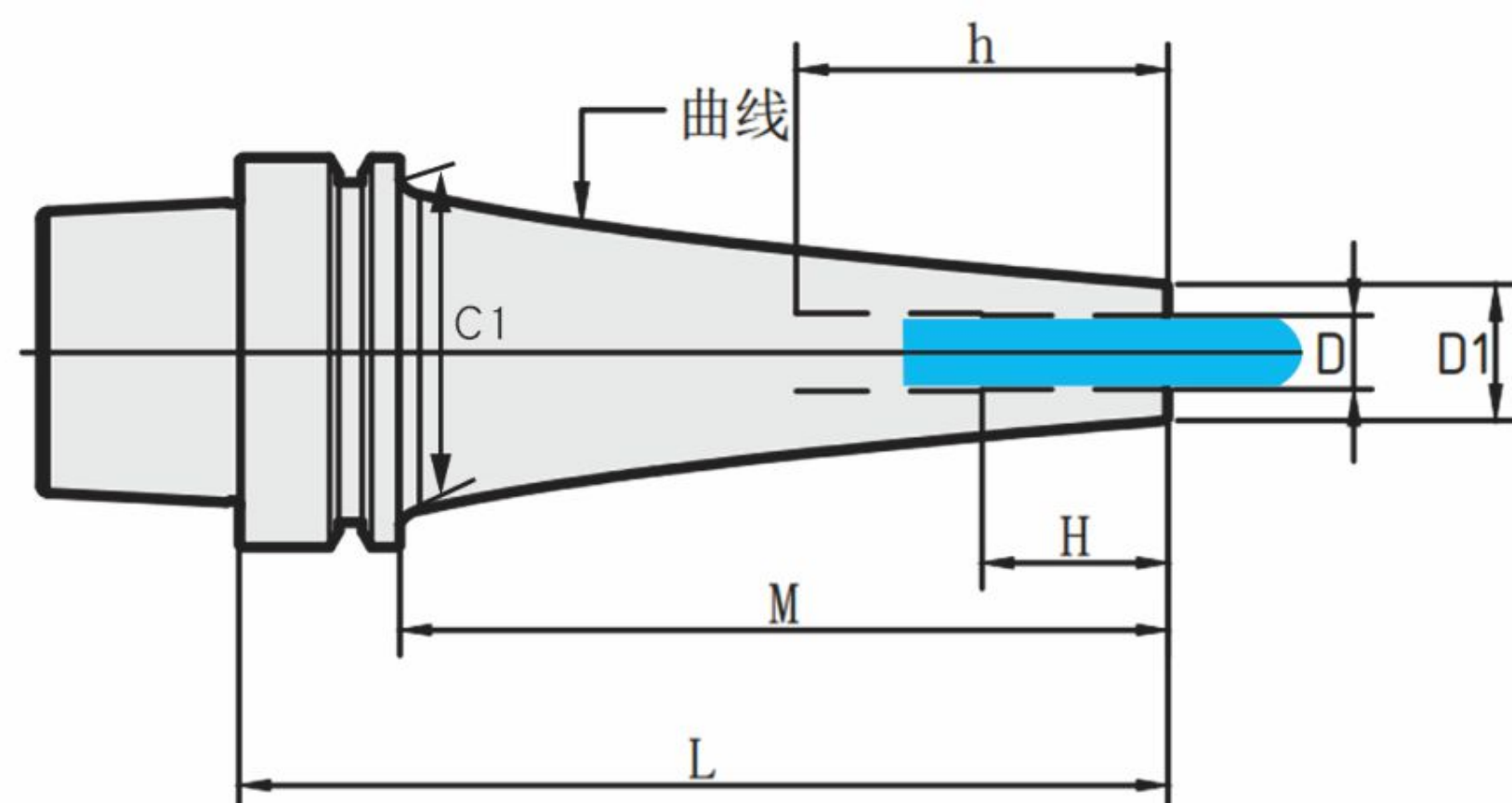
型号	D	D1	t	L	M	L1	L2	C1	D4	H	h	库存
HSK E40 SHRA10- 90 CV	10	19	4.5	90	70	-	-	34	11	30	74	
-120 CV				120	100	104						

HSK E50 整体式热胀刀柄(不锈钢材质)

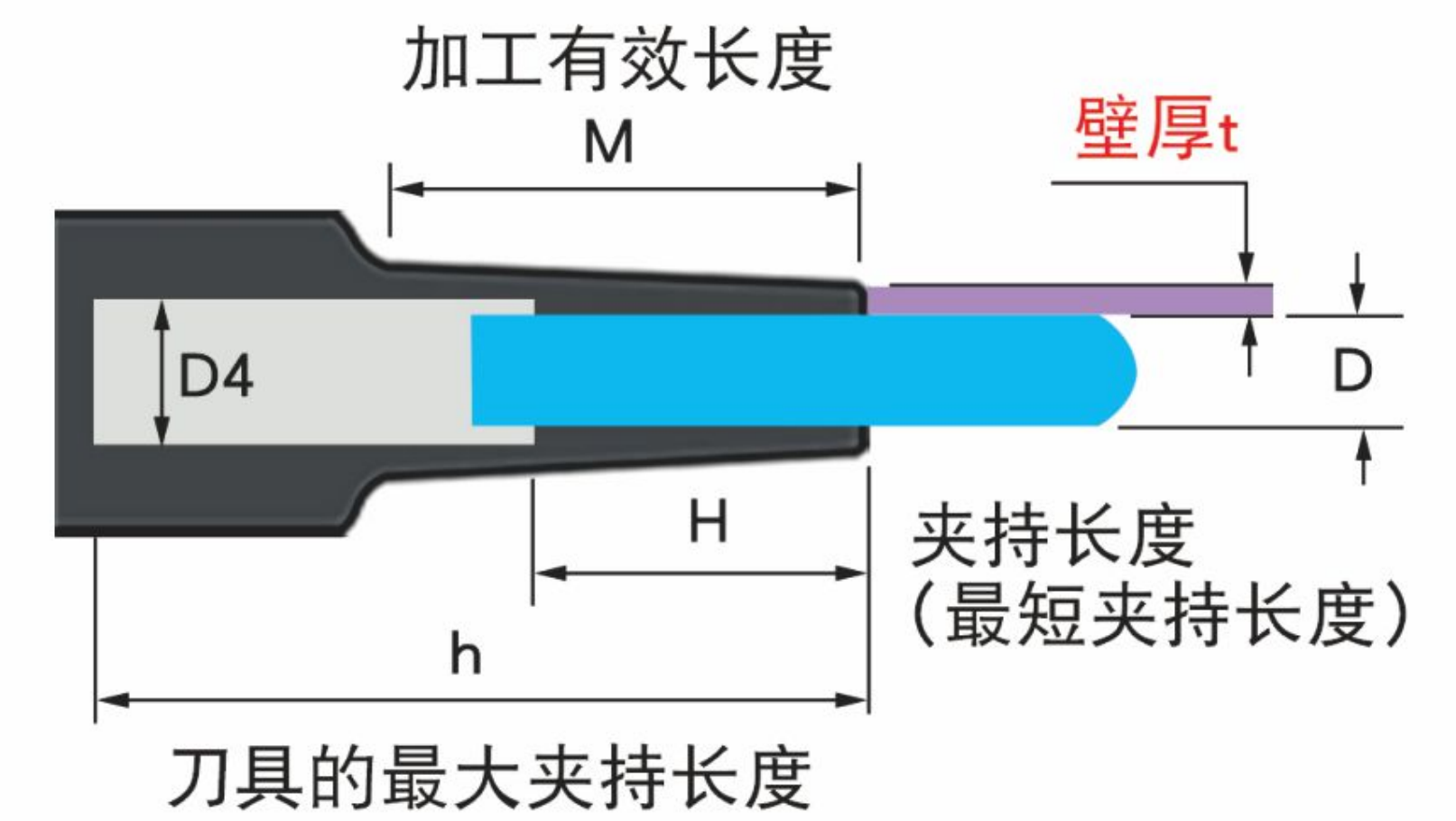
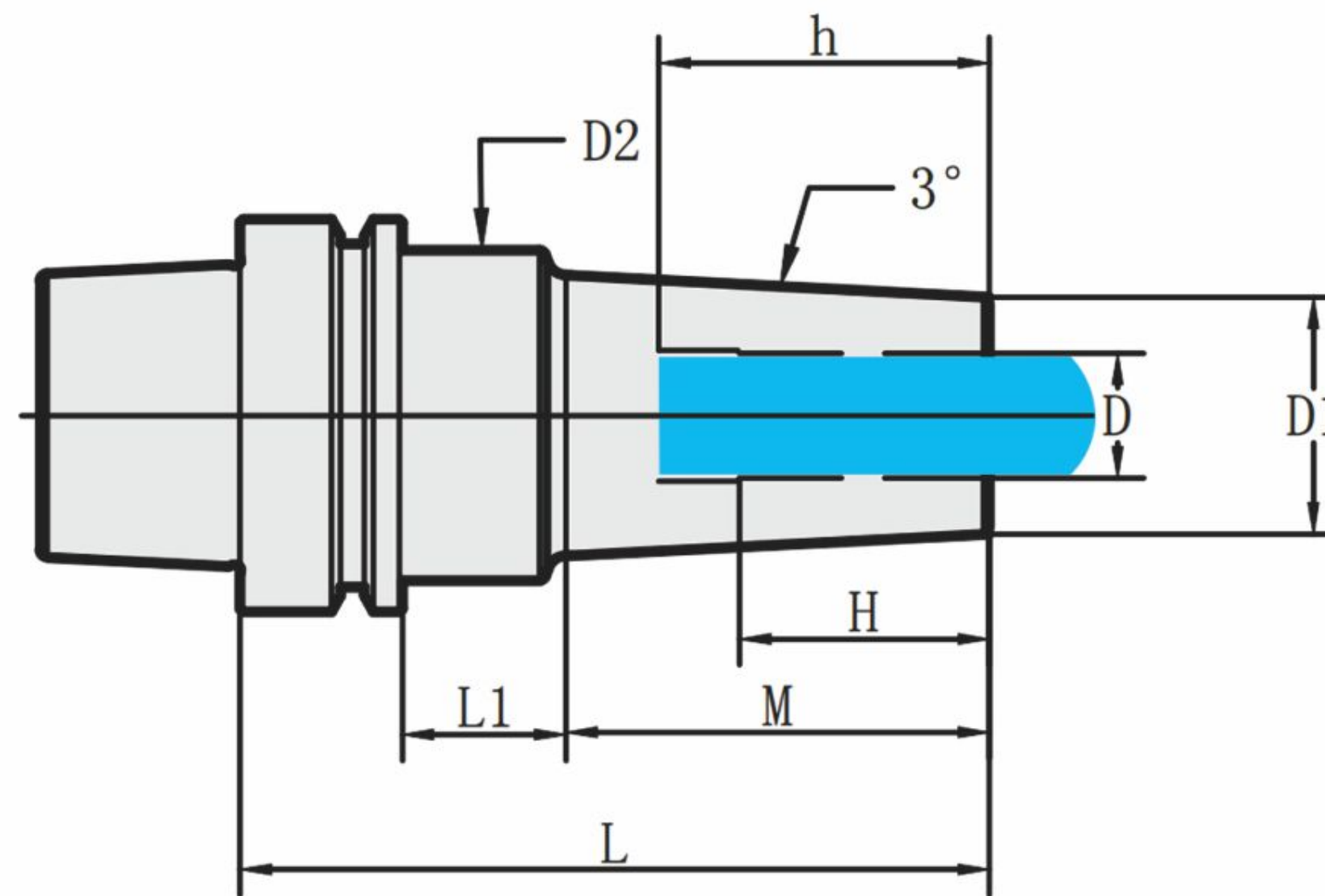

● 为常备库存 ○ 为少量库存

单位: mm

型号	D	D1	t	L	M	L1	D4	D2	D3	H	h	库存
HSK E50 SHSA4- 60-M 22	4	7	1.5	60	22	12	5	20	9.3	13	50	○
- 75-M 22				75	22	27		25	61		●	
- 80-M 42				80	42	12		20	11.4		70	●
- 95-M 42				95	42	27		25	85		●	
HSK E50 SHRA4- 75-M 22	4	10	3	75	22	27	5	25	12.3	13	61	
- 95-M 42				95	42			14.4	81			
-120-M 67				120	67			17	106			
-150-M 97				150	97			20.2	135			
HSK E50 SHSA6- 60-M 22	6	9	1.5	60	22	12	7	20	11.3	18	42	●
- 75-M 22				75	22	27		25	61		●	
- 80-M 42				80	42	12		20	13.4		62	●
- 95-M 42				95	42	27		25	81		○	
-120-M 67				120	67			16	106		○	
-150-M 97	150	97		32	19.2	135	●					
HSK E40 SHRA6- 60-M 22	6	12	3	60	22	12	6.6	26	14.3	18	44	●
- 75-M 22				75	22	27	7	25	61		●	
- 95-M 42				95	42		16.4	81	○			
-120-M 67				120	67		19	106				

型号	D	D1	t	L	M	L1	D4	D2	D3	H	h	库存
HSK E50 SHSB6- 95-M 42	6	10	2	95	42	27	6.6	25	14.4	18	77	○
-120-M 67				120	67		7	17	102		●	
-150-M 97				150	97		32	20.2	135		●	
HSK E50 SHRB6- 95-M 42	6	14	4	95	42	27	7	32	18.4	18	80	●
HSK E50 SHSA8- 65-M 22	8	11	1.5	65	22	17	8.6	26	13.3	24	49	
- 75-M 22				75	22	27	9	25	15.4		61	
- 85-M 42				85	42	17	8.6	26	67			
- 95-M 42				95	42	27	9	25	81			
-120-M 67				120	67		32	18	105		●	
-150-M 97	150	97		21.2	132	●						
HSK E50 SHRA8- 60-M 22	6	14	3	60	22	12	8.6	26	16.3	20	44	●
- 75-M 22				75	22	27	9	25	24		61	○
- 95-M 42				95	42		18.4	81	○			
HSK E50 SHSB8- 95-M 42	8	13	2.5	95	42	27	9	32	17.4	24	77	●
-120-M 67				120	67		20	105	●			
-150-M 97				150	97		23.2	132	●			
HSK E50 SHRB8- 95-M 42	8	18	5	95	42	27	9	32	22.4	24	77	○
-120-M 67				120	67		25	105				

HSK E50 整体式热胀刀柄(不锈钢材质)

型号	D	D1	t	L	M	L1	D4	D2	D3	H	h	库存	
HSK E50 SHSA10- 65-M 22	10	13	1.5	65	22	17	10.6	26	15.3	30	49		
- 75-M 22				75	22	27	11	25			61	○	
- 85-M 42				85	42	17	10.6	26	17.4		64	●	
- 95-M 42				95	42	27	11	25			81	●	
-120-M 67				120	67			32	20		105	●	
-150-M 97				150	97				23.2		135	○	
HSK E50 SHRA10- 60-M 22	10	16	3	60	22	12	10.6	26	18.3	25	44		
- 75-M 22				75	22	27	11	25			30	60	
HSK E50 SHSB10- 95-M 42	10	16	3	95	42	27	11	32	20.4	30	80	○	
-120-M 67				120	67			23	105		●		
-150-M 97				150	97			26.2	135		●		
HSK E50 SHRB10- 95-M 42	10	22	6	95	42	27	11	32	26.4	30	64	●	
-120-M 67				120	67			42	29		107		
HSK E50 SHSA12- 65-M 22	12	15	1.5	65	22	17	12.6	26	17.3	25	49	○	
- 75-M 22				75	22	27	13	25			30	60	○
- 85-M 42				85	42	17	12.6	26	19.4		64	○	
- 95-M 42				95	42	27	13	32			80	○	
-120-M 67				120	67			22	105		○		
HSK E50 SHRA12- 60-M 22	12	20	4	60	22	12	12.6	26	22.3	25	44	○	
- 75-M 22				75	22	27	13	25			30	62	○
HSK E50 SHSB12- 95-M 42	12	19	3.5	95	42	27	13	32	23.4	30	64		
-120-M 67				120	67			26	64				
-150-M 97				150	97			29.2	105				
HSK E50 SHRB12- 95-M 42	12	26	7	95	42	27	13	42	30.4	30	82		
-120-M 67				120	67			33	64				
HSK E50 SHSB16- 95-M 42	16	24	4	95	42	27	17	42	28.4	32	81		
-120-M 67				120	67			31	81				
HSK E50 SHRB16- 75-M 22	16	32	8	75	22	27	17	42	34.3		62	●	
HSK E50 SHRA16- 60-M 22	16	26	5	60	22	12	16.6	34	28.3	32	44	●	
HSK E50 SHSB20- 95-M 42	20	29	4.5	95	42	27	21	42	33.4	40	82	○	
HSK E50 SHRA20- 65-M 22	20	32	6	65	22	17	20.6	40	34.3	38	49		

HSK E50 整体式热胀刀柄(不锈钢材质)



图1

● 为常备库存 ○ 为少量库存

单位: mm

型号	D	D1	t	L	M	L1	L2	C1	D4	H	h	库存
HSK E50 SHSA4- 90 CV	4	7	1.5	90	64	-	-	42	5	13	74	○
-120 CV				120	94						104	●
-150 CV				150	124						134	●
-180 CV				180	154						164	●
HSK E50 SHRA6-120 CV	4	10	3	120	94	-	-	42	5	13	104	
-150 CV				150	124						134	
HSK E50 SHRA6- 90 CV	6	9	1.5	90	64	-	-	42	7	18	74	
-120 CV				120	94						104	
-150 CV				150	124						134	●
-180 CV				180	154						164	●
HSK E50 SHRA6-120 CV	6	13	3.5	120	94	-	-	42	7	18	104	●
-150 CV				150	124						132	○
HSK E50 SHSA8- 90 CV	8	11	1.5	90	64	-	-	42	9	24	74	○
-120 CV				120	94						104	●
-150 CV				150	124						134	●
-180 CV				180	154						164	●
HSK E50 SHRA8-120 CV	8	16	4	120	94	-	-	42	9	24	102	○
-150 CV				150	124						132	

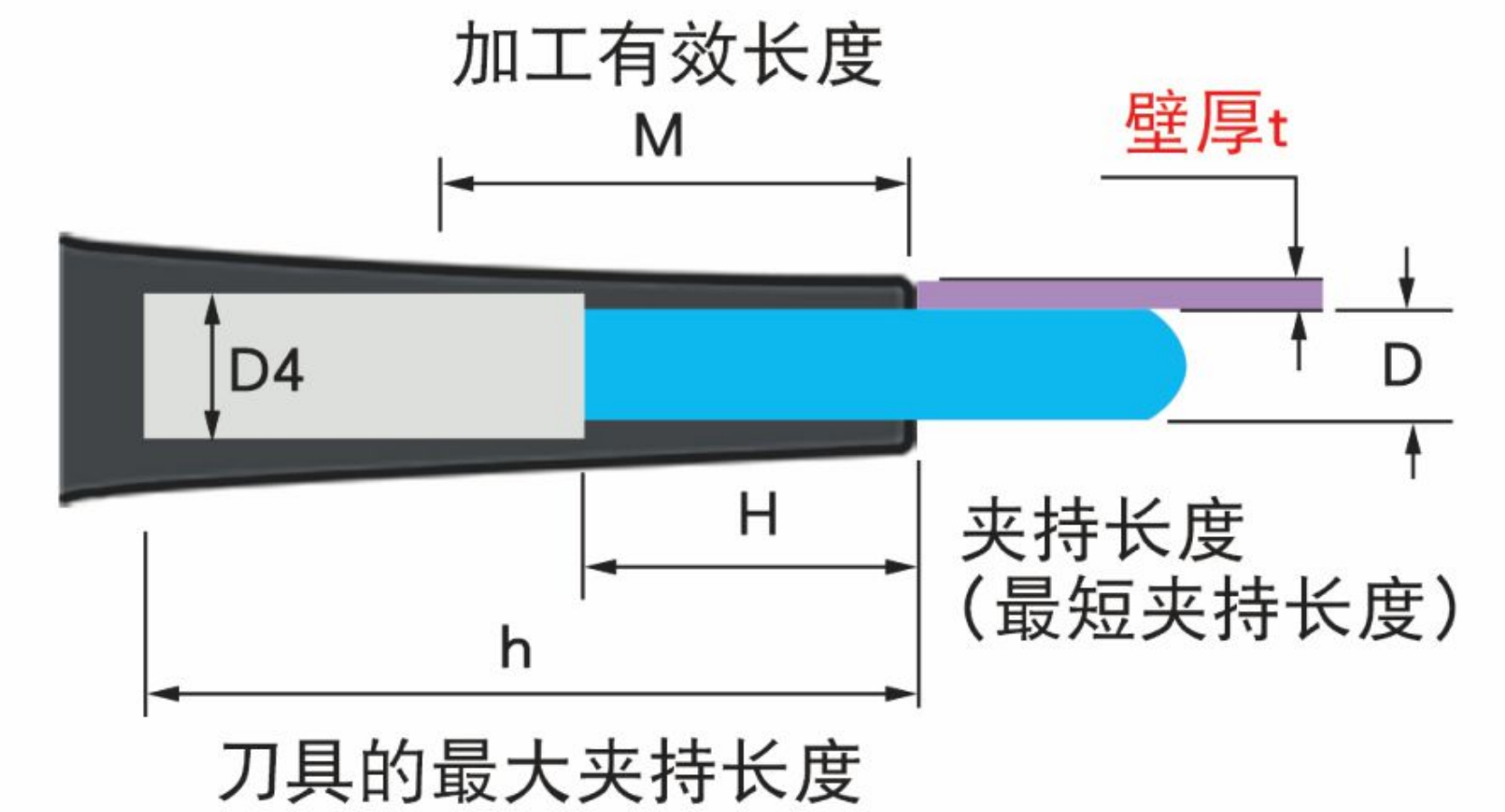
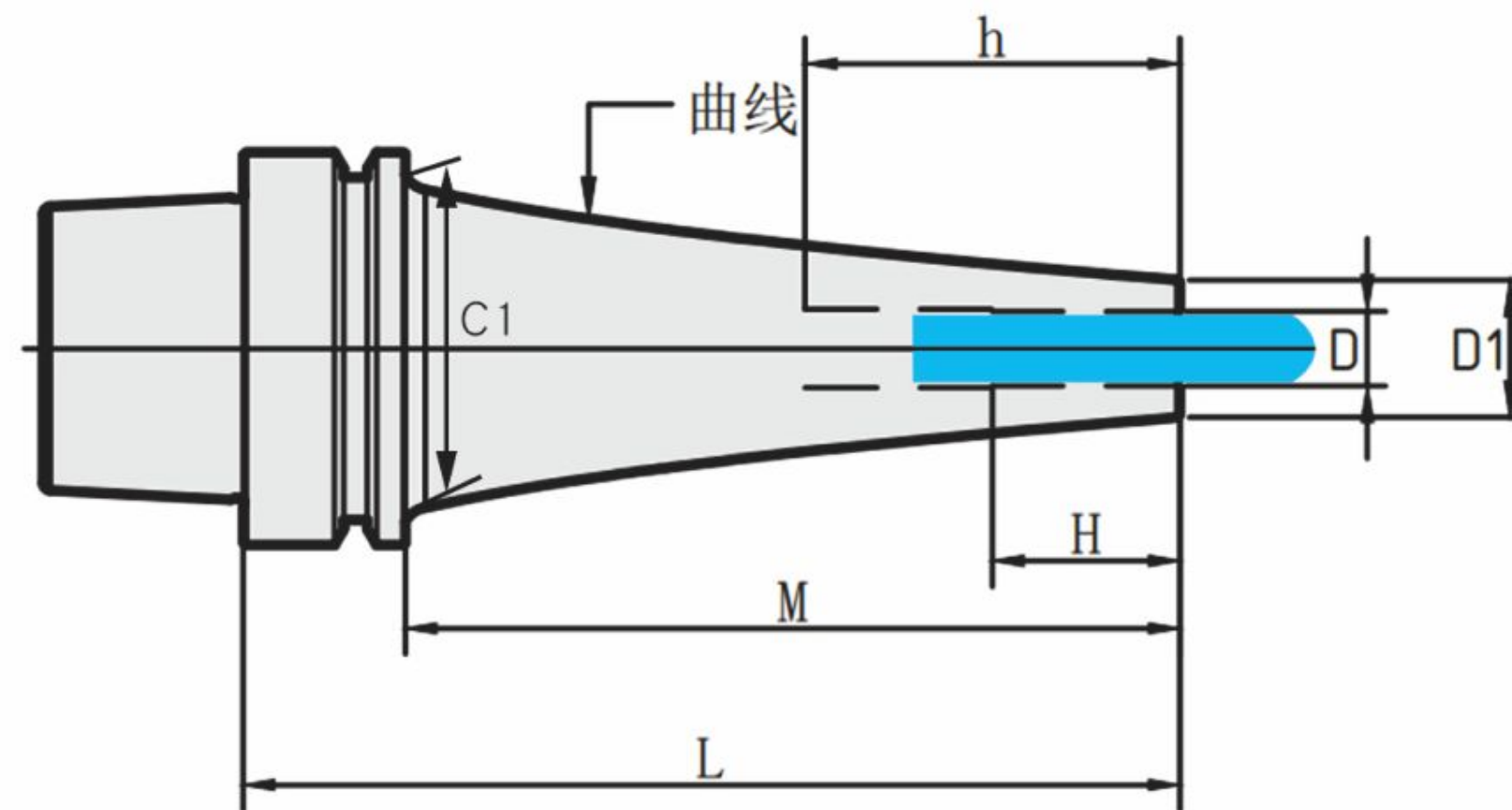
型号	D	D1	t	L	M	L1	L2	C1	D4	H	h	库存
HSK E50 SHSA10- 90 CV	10	19	4.5	90	64	-	-	42	11	30	74	
-120 CV				120	94						104	
-150 CV				150	124						134	
-180 CV				180	154						164	
HSK E50 SHRA10-150 CV	10	19	4.5	150	124	-	-	42	11	30	132	

热胀刀柄-BT(深腔型)

MAS 403	Taper Accuracy	G Value	RPM	Coolant System
-BT	AT3	2.5	25000	



图1



图2

● 库存 Stock

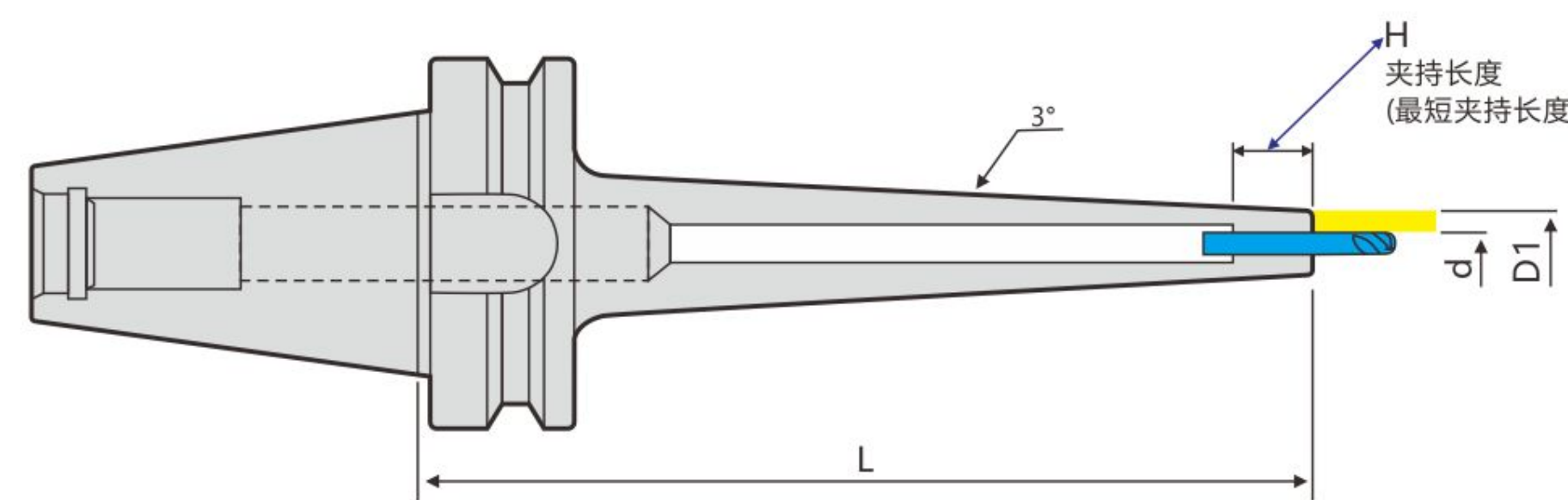
单位: mm

型号	图	d	D1	D2	D3	壁厚 (t)	L	L1	L2	L3	H	库存
BT30-SHB3-80	1	3	9			3	80				10	○
BT30-SHB4-80		4	10			4	80				13	●
BT30-SHB4-120		4	10			4	120				13	●
BT30-SHB6-80		6	13			4	80				20	●
BT30-SHB6-120		6	13			4	120				20	●
BT30-SHB8-80		8	15			4	80				25	●
BT30-SHB8-120		8	15			4	120				25	●
BT30-SHB10-80		10	17			4.5	80				30	●
BT30-SHB10-120		10	18			4.5	120				30	●
BT30-SHB12-80		12	20			4.5	80				30	●
BT30-SHB12-120		12	20			4.5	120				30	●
BT30-SHB16-90		16	26		38	6.5	90		70		32	●
BT30-SHB16-120		16	28		38	6.5	120		80		32	●
BT30-SHB20-90		20	32		40	6.5	90		70		40	●
BT30-SHB20-120		20	32		40	6.5	120		80		40	●
BT40-SHB3-90		3	9			3	90				10	○
BT40-SHB4-90		4	10			4	90				13	●
BT40-SHB4-120		4	10			4	120				13	●
BT40-SHB4-155		4	10			4	155				13	●
BT40-SHB4-185		4	10			4	185				13	●
BT40-SHB6-90		6	13			4	90				20	●
BT40-SHB6-120		6	13			4	120				20	●
BT40-SHB6-155		6	13			4	155				20	●
BT40-SHB6-185		6	13			4	185				20	●
BT40-SHB8-90	8	15			4	90				25	●	
BT40-SHB8-120	8	15			4	120				25	●	
BT40-SHB8-155	8	16			4	155				25	●	
BT40-SHB8-185	8	16			4	185				25	●	
BT40-SHB10-90	10	17			4.5	90				30	●	
BT40-SHB10-120	10	18			4.5	120				30	●	
BT40-SHB10-155	10	18			4.5	155				30	●	
BT40-SHB10-185	10	18			4.5	185				30	●	
BT40-SHB12-90	12	20			4.5	90				30	●	
BT40-SHB12-120	12	20			4.5	120				30	●	
BT40-SHB12-155	12	20			4.5	155				30	●	
BT40-SHB12-185	12	20			4.5	185				30	●	

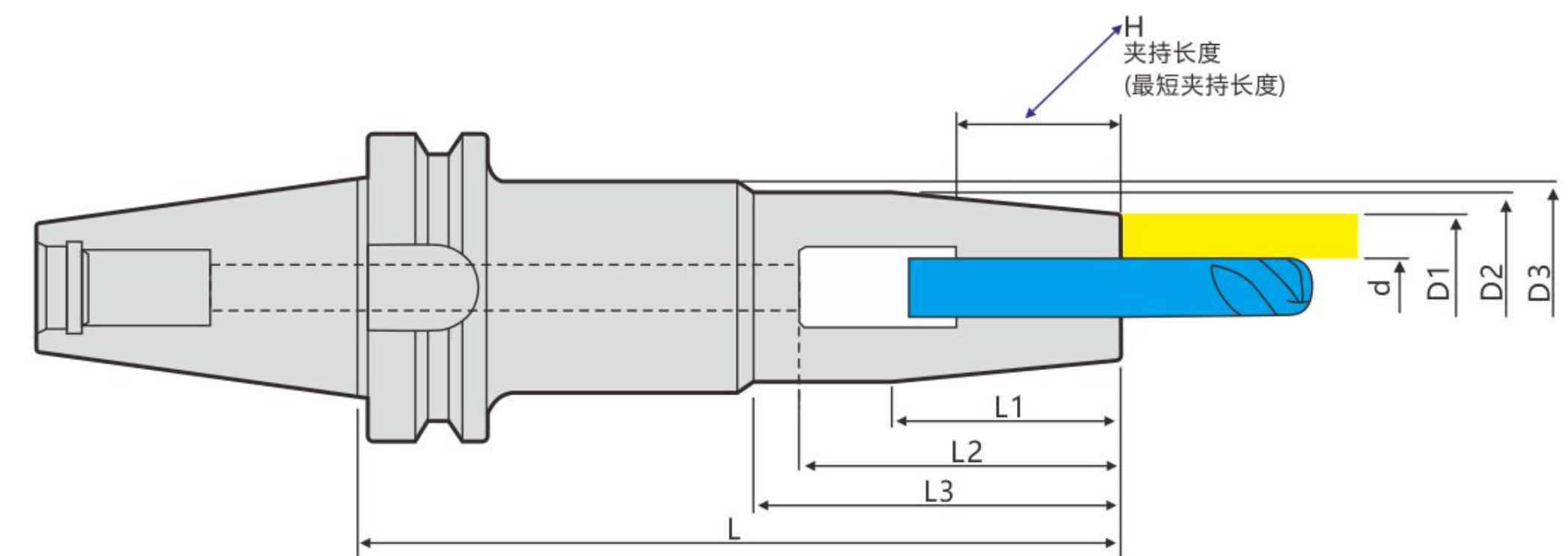
型号	图	d	D1	D2	D3	壁厚 (t)	L	L1	L2	L3	H	库存	
BT40-SHB16-90	1	16	29		38	6.5	90		80		32	●	
BT40-SHB16-130	2	16	29	38	38	6.5	130	50	80		32	●	
BT40-SHB16-160		16	29	38	42	6.5	160	50	80	80	32	●	
BT40-SHB16-200	1	16	29	38	42	6.5	200	50	80	80	32	○	
BT40-SHB20-90		20	33		42	6.5	90		80		40	●	
BT40-SHB20-130	2	20	33	42	42	6.5	130	56	80		40	●	
BT40-SHB20-160		20	33	42	42	6.5	160	56	80	90	40	●	
BT40-SHB20-200	2	20	33	42	48	6.5	200	56	80	90	40	○	
BT40-SHB25-100		25	41		45	8	90	60	80		45	●	
BT40-SHB25-130	2	25	41		45	8	130	60	80		45	●	
BT40-SHB25-160		25	41	45	50	8	160	60	80	90	45	●	
BT40-SHB25-200	2	25	41	45	50	8	200	60	80	90	45	●	
BT50-SHB4-100		1	4	10			4	100				13	○
BT50-SHB4-160	4		10			4	160				13	○	
BT50-SHB4-200	4		11			4	200				13	○	
BT50-SHB6-100	1		6	13			4	100				20	○
BT50-SHB6-160			6	13			4	160				20	○
BT50-SHB6-200	1		6	13			4	200				20	○
BT50-SHB8-100			8	15			4	100				25	○
BT50-SHB8-160	1		8	16			4	160				25	○
BT50-SHB8-200			8	16			4	200				25	○
BT50-SHB10-100	1		10	18			4.5	100				30	○
BT50-SHB10-160			10	18			4.5	160				30	○
BT50-SHB10-200	1		10	18			4.5	200				30	○
BT50-SHB12-100		12	20			4.5	100				30	○	
BT50-SHB12-160	1	12	20			4.5	160				30	○	
BT50-SHB12-200		12	20			4.5	200				30	○	
BT50-SHB16-100	1	16	29		38	6.5	100		80		32	○	
BT50-SHB16-160	2	16	29	38	42	6.5	160	50	80	80	32	○	
BT50-SHB16-200		16	29	38	42	6.5	200	50	80	80	32	○	
BT50-SHB20-100	1	20	33		42	6.5	100		80		40	○	
BT50-SHB20-160	2	20	33	42	42	6.5	160	56	80	90	40	○	
BT50-SHB20-200		20	33	42	48	6.5	200	56	80	90	40	○	
BT50-SHB25-115	2	25	41		45	8	100	60	80		45	○	
BT50-SHB25-160		25	41	45	50	8	160	60	80	90	45	○	
BT50-SHB25-200	2	25	41	45	50	8	200	60	80	90	45	○	

热胀刀柄-HSK E40/E50(深腔型)

MAS 403	Taper Accuracy	G Value	RPM	Coolant System
-HSK	AT3	2.5	25000	



图1



图2

● 库存 Stock

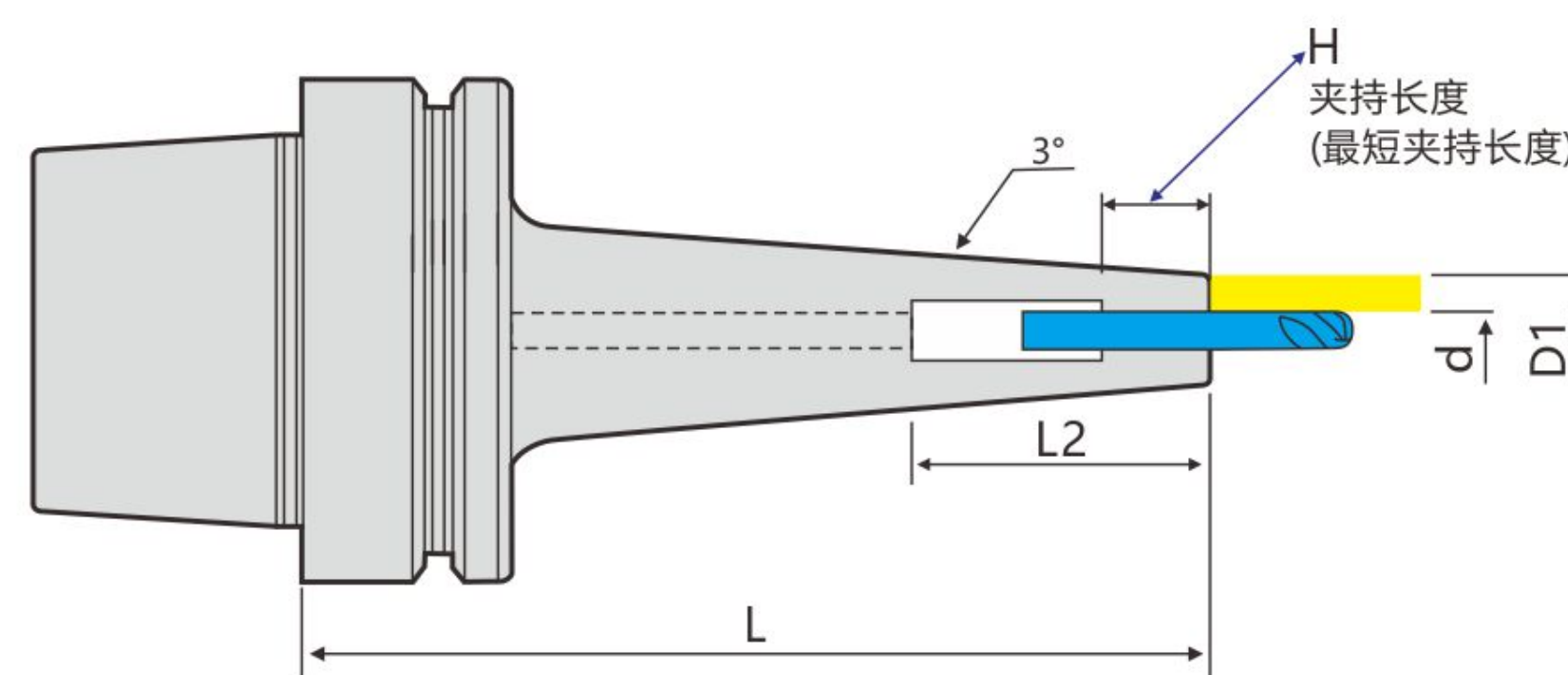
单位: mm

型号	图	d	D1	D2	D3	壁厚 (t)	L	L1	L2	L3	H	库存	
HSK E40-SHB3-80	1	3	9			3	80				10	○	
HSK E40-SHB4-80		4	10			3	80				13	●	
HSK E40-SHB4-120		4	10			3	120				13	●	
HSK E40-SHB6-80		6	13			3.5	80				20	●	
HSK E40-SHB6-120		6	13			3.5	120				20	●	
HSK E40-SHB8-80		8	15			3.5	80				25	●	
HSK E40-SHB8-120		8	15			3.5	120				25	●	
HSK E40-SHB10-90		10	17			3.5	90	55			30	●	
HSK E40-SHB10-120		10	18			4	120	55			30	●	
HSK E40-SHB12-90		12	20			4	90	55			30	●	
HSK E40-SHB12-120		12	20			4	120	55			30	●	
HSK E40-SHB16-90		2	16	26		38	5	90	70			32	●
HSK E40-SHB16-120			16	26		38	5	120	80			32	●
HSK E40-SHB20-90			20	33		40	6	90	70			40	●
HSK E40-SHB20-120	20		33		40	6	120	80			40	●	
HSK E50-SHB3-90	1	3	9			3	90				10	○	
HSK E50-SHB4-90		4	10			3	90				13	●	
HSK E50-SHB4-120		4	10			3	120				13	●	
HSK E50-SHB4-150		4	10			3	150				13	●	

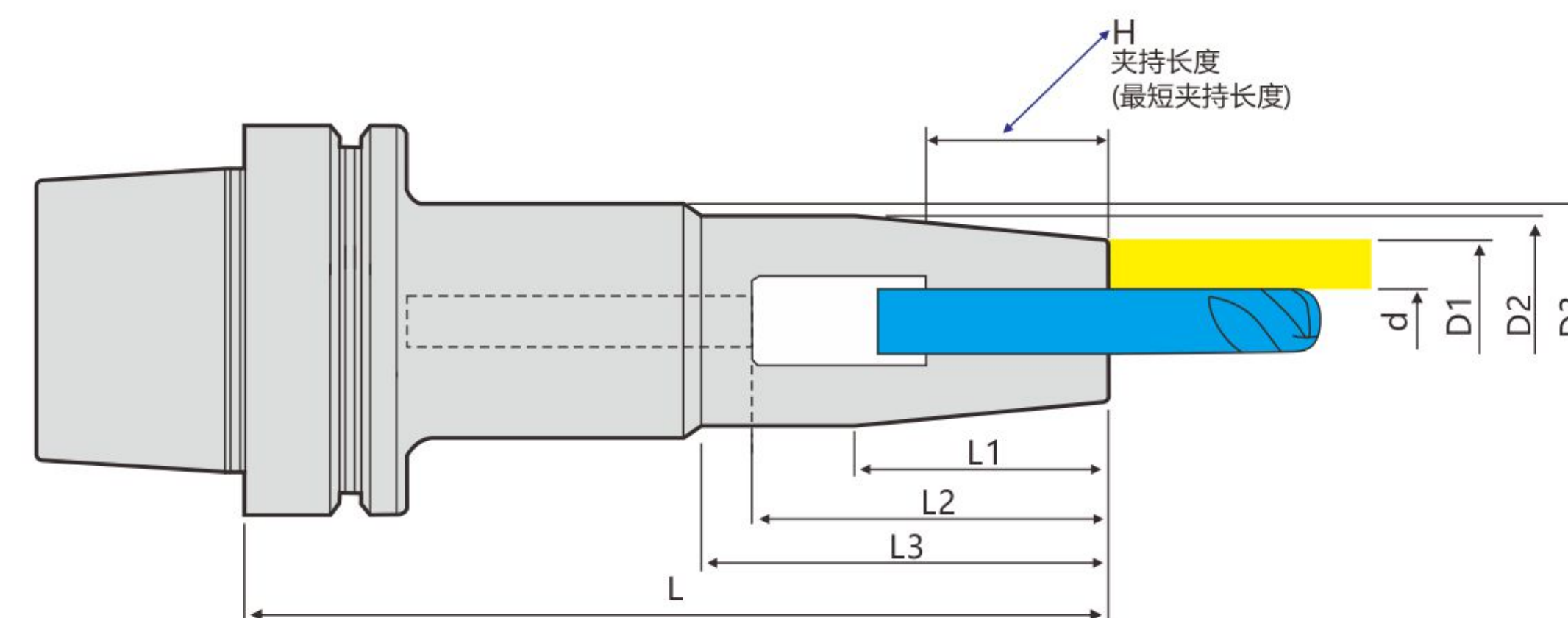
型号	图	d	D1	D2	D3	壁厚 (t)	L	L1	L2	L3	H	库存	
HSK E50-SHB6-90	1	6	13			3.5	90				20	●	
HSK E50-SHB6-120		6	13			3.5	120				20	●	
HSK E50-SHB6-150		6	13			3.5	150				20	●	
HSK E50-SHB8-90		8	15			3.5	90				25	●	
HSK E50-SHB8-120		8	15			3.5	120				25	●	
HSK E50-SHB8-150		8	16			4	150				25	●	
HSK E50-SHB10-90		10	17			3.5	90		55		30	●	
HSK E50-SHB10-120		10	18			4	120		55		30	●	
HSK E50-SHB10-150		10	18			4	150		55		30	●	
HSK E50-SHB12-90		12	20			4	90		55		30	●	
HSK E50-SHB12-120		12	20			4	120		55		30	●	
HSK E50-SHB12-150		12	20			4	150		55		30	●	
HSK E50-SHB16-90		2	16	26		38	5	90		70		32	●
HSK E50-SHB16-120			16	26		38	5	120		80		32	●
HSK E50-SHB16-150	16		29	38	42	6.5	150	50	80		32	○	
HSK E50-SHB20-90	20		33		40	6.5	90		70		40	●	
HSK E50-SHB20-120	20		33		42	6.5	120		80		40	●	
HSK E50-SHB20-150	20	33	42	42	6.5	150	56	80	80	40	○		

热胀刀柄-HSK A63/A100(深腔型)

MAS 403	Taper Accuracy	G Value	RPM	Coolant System
-HSK	AT3	2.5	25000	



图1



图2

● 库存 Stock

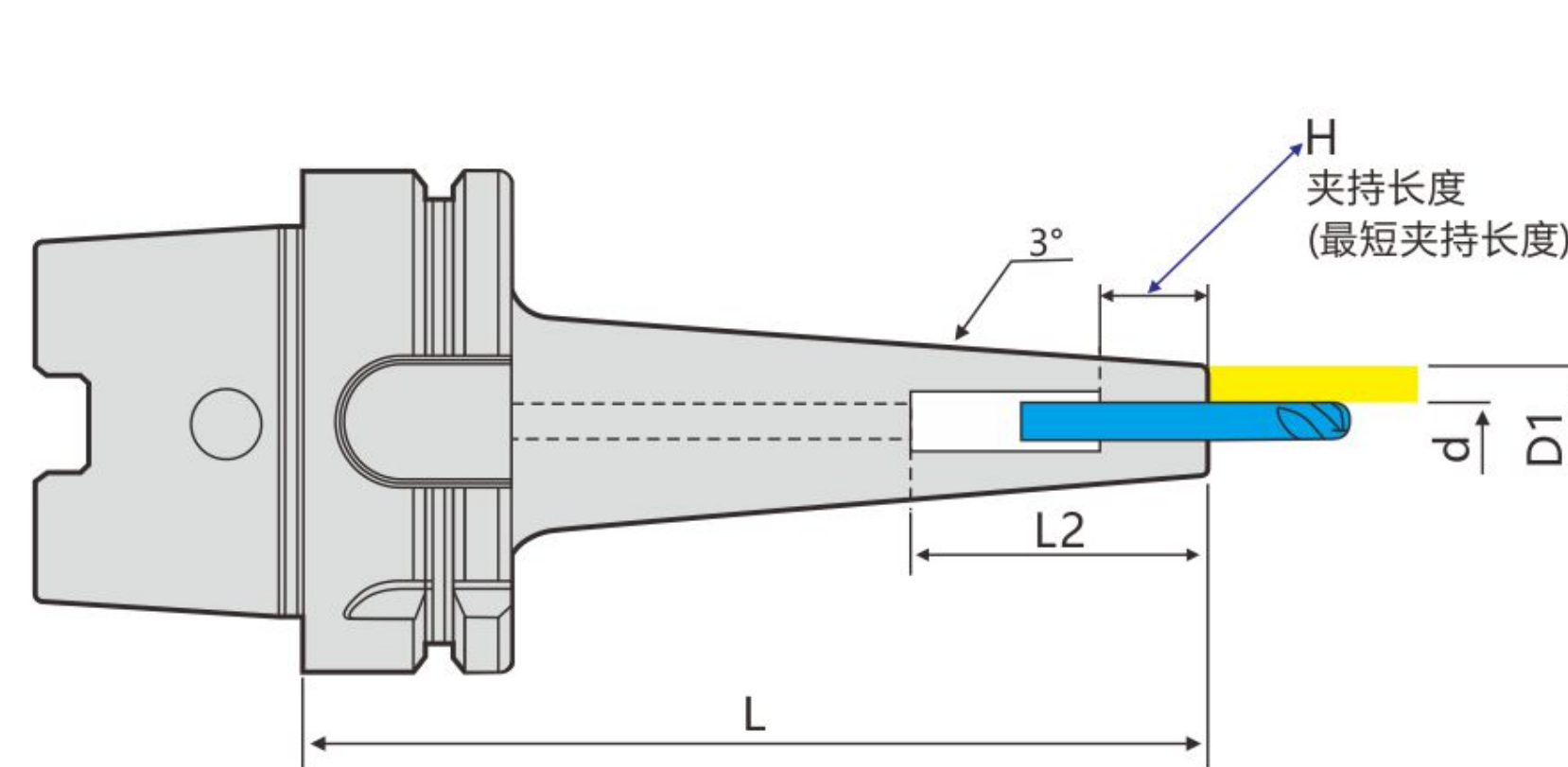
单位: mm

型号	图	d	D1	D2	D3	壁厚 (t)	L	L1	L2	L3	H	库存	
HSKA63-SHB3-80	1	3	9			3	80				10	○	
HSKA63-SHB4-80		4	12			4	80				13	●	
HSKA63-SHB4-120		4	12			4	120				13	●	
HSKA63-SHB4-160		4	12			4	160				13	●	
HSKA63-SHB4-200		4	12			4	200				13	●	
HSKA63-SHB6-80		6	14			4	80					20	●
HSKA63-SHB6-120		6	14			4	120					20	●
HSKA63-SHB6-160		6	14			4	160					20	●
HSKA63-SHB6-200		6	14			4	200					20	●
HSKA63-SHB8-80		8	16			4	80					25	●
HSKA63-SHB8-120		8	16			4	120					25	●
HSKA63-SHB8-160		8	16			4	160					25	●
HSKA63-SHB8-200		8	16			4	200					25	●
HSKA63-SHB10-80		10	19			4.5	80		55			30	●
HSKA63-SHB10-120		10	19			4.5	120		55			30	●
HSKA63-SHB10-160		10	19			4.5	160		55			30	●
HSK A63-SHB10-200		10	19			4.5	200		55			30	●
HSKA63-SHB12-80		12	21			4.5	80		55			30	●
HSKA63-SHB12-120		12	21			4.5	120		55			30	●
HSKA63-SHB12-160		12	21			4.5	160		55			30	●
HSKA63-SHB12-200	12	21			4.5	200		55			30	○	
HSKA63-SHB16-95	1	16	29		38	6.5	95		80		32	●	
HSKA63-SHB16-130	2	16	29	38	38	6.5	130	60	80		32	●	
HSKA63-SHB16-160		16	29	38	42	6.5	160	60	80	80	32	●	
HSKA63-SHB16-200		16	29	38	42	6.5	200	60	80	80	32	●	
HSKA63-SHB20-100	1	20	33		42	6.5	100		80		40	●	
HSKA63-SHB20-130	2	20	33	42	42	6.5	130	56	80		40	●	
HSKA63-SHB20-160		20	33	42	48	6.5	160	56	80	90	40	●	
HSKA63-SHB20-200		20	33	42	48	6.5	200	56	80	90	40	●	

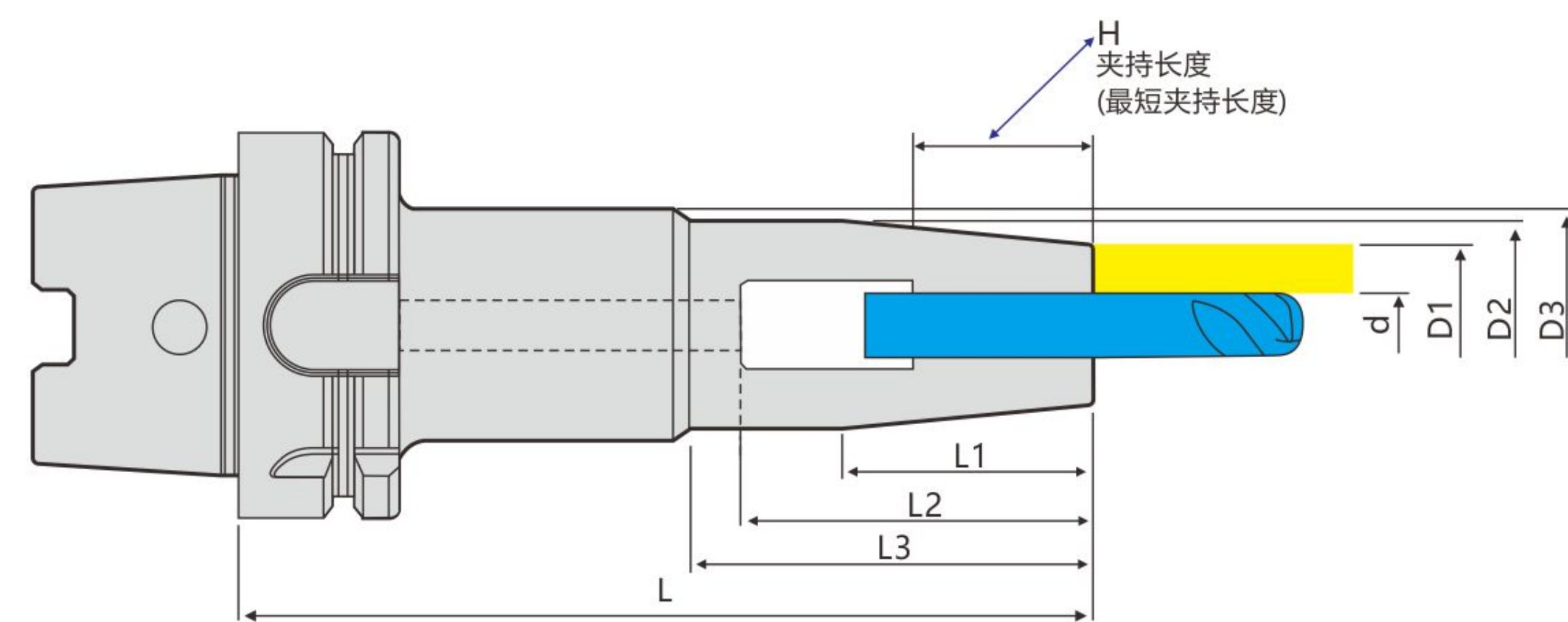
型号	图	d	D1	D2	D3	壁厚 (t)	L	L1	L2	L3	H	库存	
HSKA63-SHB25-115	2	25	41		45	8	115	60	80		45	●	
HSKA63-SHB25-130		25	41		45	8	130	60	80		45	●	
HSK A63-SHB25-160		25	41	45	50	8	160	60	80	90	45	●	
HSK A63-SHB25-200		25	41	45	50	8	200	60	80	90	45	●	
HSKA100-SHB4-100	1	4	12			4	100				13	○	
HSKA100-SHB4-160		4	12			4	160				13	○	
HSKA100-SHB4-200		4	12			4	200				13	○	
HSKA100-SHB6-100		6	14			4	100				20	○	
HSKA100-SHB6-160		6	14			4	160				20	○	
HSKA100-SHB6-200		6	14			4	200				20	○	
HSKA100-SHB8-100		8	16			4	100				25	○	
HSKA100-SHB8-160		8	16			4	160				25	○	
HSKA100-SHB8-200		8	16			4	200				25	○	
HSKA100-SHB10-100		10	19			4.5	100				30	○	
HSKA100-SHB10-160		10	19			4.5	160				30	○	
HSKA100-SHB10-200		10	19			4.5	200				30	○	
HSKA100-SHB12-100	2	12	21			4.5	100				30	○	
HSK A100-SHB12-160		12	21			4.5	160				30	○	
HSKA100-SHB12-200		12	21			4.5	200				30	○	
HSKA100-SHB16-100		1	16	29		38	6.5	100		80		32	○
HSKA100-SHB16-160		2	16	29	38	42	6.5	160	50	80	80	32	○
HSKA100-SHB16-200		2	16	29	38	42	6.5	200	50	80	80	32	○
HSKA100-SHB20-100	1	20	33		42	6.5	100		80		40	○	
HSKA100-SHB20-160	2	20	33	42	42	6.5	160	56	80	90	40	○	
HSKA100-SHB20-200		20	33	42	48	6.5	200	56	80	90	40	○	
HSK A100-SHB25-115		25	41		45	8	100	60	80		45	○	
HSKA100-SHB25-160		25	41	45	50	8	160	60	80	90	45	○	
HSK A100-SHB25-200	25	41	45	50	8	200	60	80	90	45	○		

热胀刀柄-BT(标准型)

MAS 403	Taper Accuracy	G Value	RPM	Coolant System
-BT	AT3	2.5	25000	

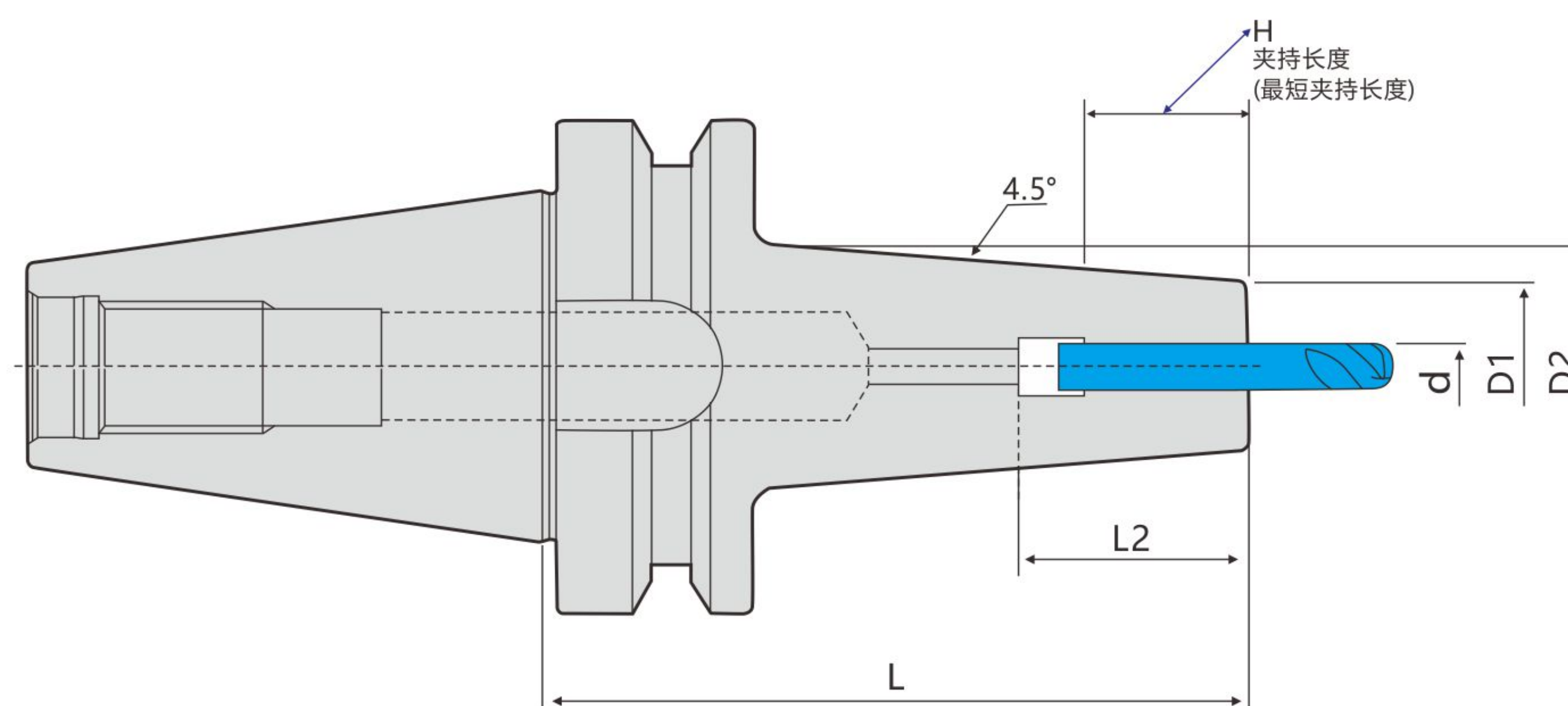

● 库存 Stock

单位: mm

型号	d	D1	D2	L	L2	H	库存
BT30-SHA3-60	3	11	15	60	20	10	○
BT30-SHA4-60	4	15	20	60	20	13	○
BT30-SHA6-80	6	21	27	80	36	20	○
BT30-SHA8-80	8	21	27	80	36	25	○
BT30-SHA10-80	10	24	32	80	40	30	○
BT30-SHA12-80	12	24	32	80	45	30	○
BT30-SHA16-80	16	27	34	80	48	32	○
BT40-SHA3-90	3	11	15	90	20	10	○
BT40-SHA4-90	4	15	20	90	20	13	○
BT40-SHA6-90	6	21	27	90	36	20	○
BT40-SHA6-120	6	21	27	120	36	20	○
BT40-SHA6-160	6	21	27	160	36	20	○
BT40-SHA8-90	8	21	27	90	36	25	○
BT40-SHA8-120	8	21	27	120	36	25	○
BT40-SHA8-160	8	21	27	160	36	25	○
BT40-SHA10-90	10	24	32	90	40	30	○
BT40-SHA10-120	10	24	32	120	40	30	○
BT40-SHA10-160	10	24	32	160	40	30	○
BT40-SHA12-90	12	24	32	90	45	30	○
BT40-SHA12-120	12	24	32	120	45	30	○
BT40-SHA12-160	12	24	32	160	45	30	○
BT40-SHA16-90	16	27	34	90	48	32	○
BT40-SHA16-120	16	27	34	120	48	32	○

型号	d	D1	D2	L	L2	H	库存
BT40-SHA16-160	16	27	34	160	48	32	○
BT40-SHA20-90	20	33	42	90	50	40	○
BT40-SHA20-120	20	33	42	120	50	40	○
BT40-SHA20-160	20	33	42	160	50	40	○
BT40-SHA25-100	25	44	53	100	56	45	○
BT40-SHA25-160	25	44	53	160	56	45	○
BT50-SHA3-100	3	11	15	100	20	10	○
BT50-SHA4-100	4	15	20	100	20	13	○
BT50-SHA4-160	4	15	20	160	20	13	○
BT50-SHA6-100	6	21	27	100	36	20	○
BT50-SHA6-160	6	21	27	160	36	20	○
BT50-SHA8-100	8	21	27	100	36	25	○
BT50-SHA8-160	8	21	27	160	36	25	○
BT50-SHA10-100	10	24	32	100	40	30	○
BT50-SHA10-160	10	24	32	160	40	30	○
BT50-SHA12-100	12	24	32	100	45	30	○
BT50-SHA12-160	12	24	32	160	45	30	○
BT50-SHA16-100	16	27	34	100	48	32	○
BT50-SHA16-160	16	27	34	160	48	32	○
BT50-SHA20-100	20	33	42	100	50	40	○
BT50-SHA20-160	20	33	42	160	50	40	○
BT50-SHA25-100	25	44	53	100	56	45	○
BT50-SHA25-160	25	44	53	160	56	45	○

热胀刀柄-HSK(标准型)

MAS 403	Taper Accuracy	G Value	RPM	Coolant System
-HSK	AT3	2.5	25000	

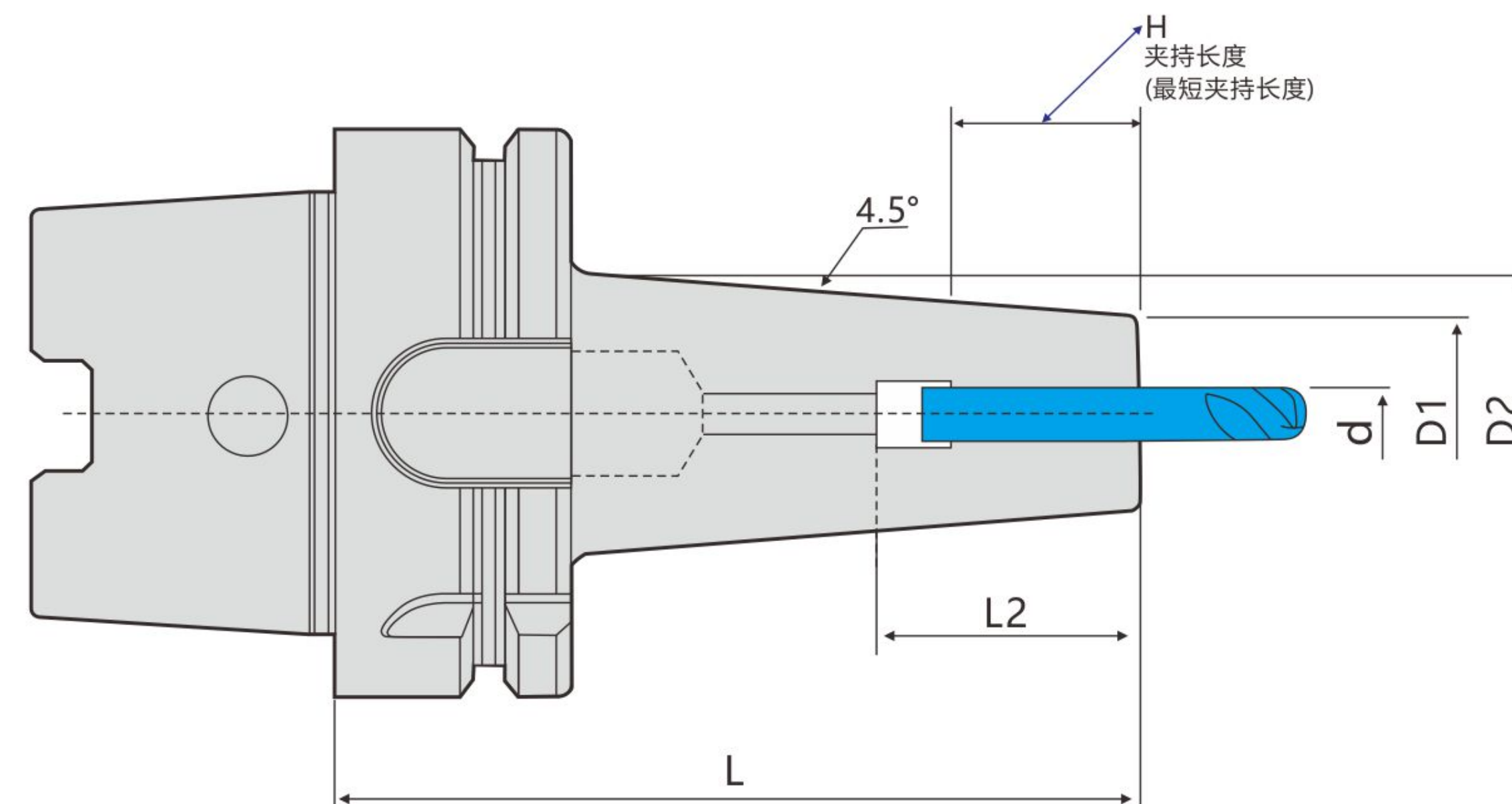

● 库存 Stock

单位: mm

型号	d	D1	D2	L	L2	H	库存
HSK E40-SHA3-80	3	11	15	80	20	10	○
HSK E40-SHA4-80	4	15	20	80	20	13	○
HSK E40-SHA6-80	6	21	27	80	36	20	○
HSK E40-SHA8-80	8	21	27	80	36	25	○
HSK E40-SHA10-80	10	24	32	90	40	30	○
HSK E40-SHA12-90	12	24	32	90	45	30	○
HSK E50-SHA3-90	3	11	15	90	20	10	○
HSK E50-SHA4-90	4	15	20	90	20	13	○
HSK E50-SHA6-90	6	21	27	90	36	20	○
HSK E50-SHA8-90	8	21	27	90	36	25	○
HSK E50-SHA10-90	10	24	32	90	40	30	○
HSK E50-SHA12-90	12	24	32	90	45	30	○
HSK E50-SHA16-95	16	27	34	90	48	32	○

型号	d	D1	D2	L	L2	H	库存
HSK A63-SHA3-80	3	11	15	80	20	10	○
HSK A63-SHA4-80	4	15	20	80	20	13	○
HSK A63-SHA4-120	4	15	20	120	20	13	○
HSK A63-SHA4-160	4	15	20	160	20	13	○
HSK A63-SHA6-80	6	21	27	80	36	20	○
HSK A63-SHA6-120	6	21	27	120	36	20	○
HSK A63-SHA6-160	6	21	27	160	36	20	○
HSK A63-SHA8-80	8	21	27	80	36	25	○
HSK A63-SHA8-120	8	21	27	120	36	25	○
HSK A63-SHA8-160	8	21	27	160	36	25	○
HSK A63-SHA10-85	10	24	32	85	40	30	○
HSK A63-SHA10-120	10	24	32	120	40	30	○
HSK A63-SHA10-160	10	24	32	160	40	30	○
HSK A63-SHA12-90	12	24	32	90	45	30	○
HSK A63-SHA12-120	12	24	32	120	45	30	○
HSK A63-SHA12-160	12	24	32	160	45	30	○
HSK A63-SHA16-95	16	27	34	95	48	32	○
HSK A63-SHA16-120	16	27	34	120	48	32	○
HSK A63-SHA16-160	16	27	34	160	48	32	○
HSK A63-SHA20-100	20	33	42	100	50	40	○
HSK A63-SHA20-120	20	33	42	120	50	40	○
HSK A63-SHA20-160	20	33	42	160	50	40	○
HSK A63-SHA25-115	25	44	53	115	56	45	○
HSK A63-SHA25-160	25	44	53	160	56	45	○

SLD模特(侧锁式)延长杆

产品特点

- 抗震能力强
- 精度高 (0~0.01mm)
- 侧锁式 (装夹方便)
- 小径深腔加工利器
(替代ER延长杆)
- 关于配件：专用锁紧螺丝，请勿随意安装其他螺丝。

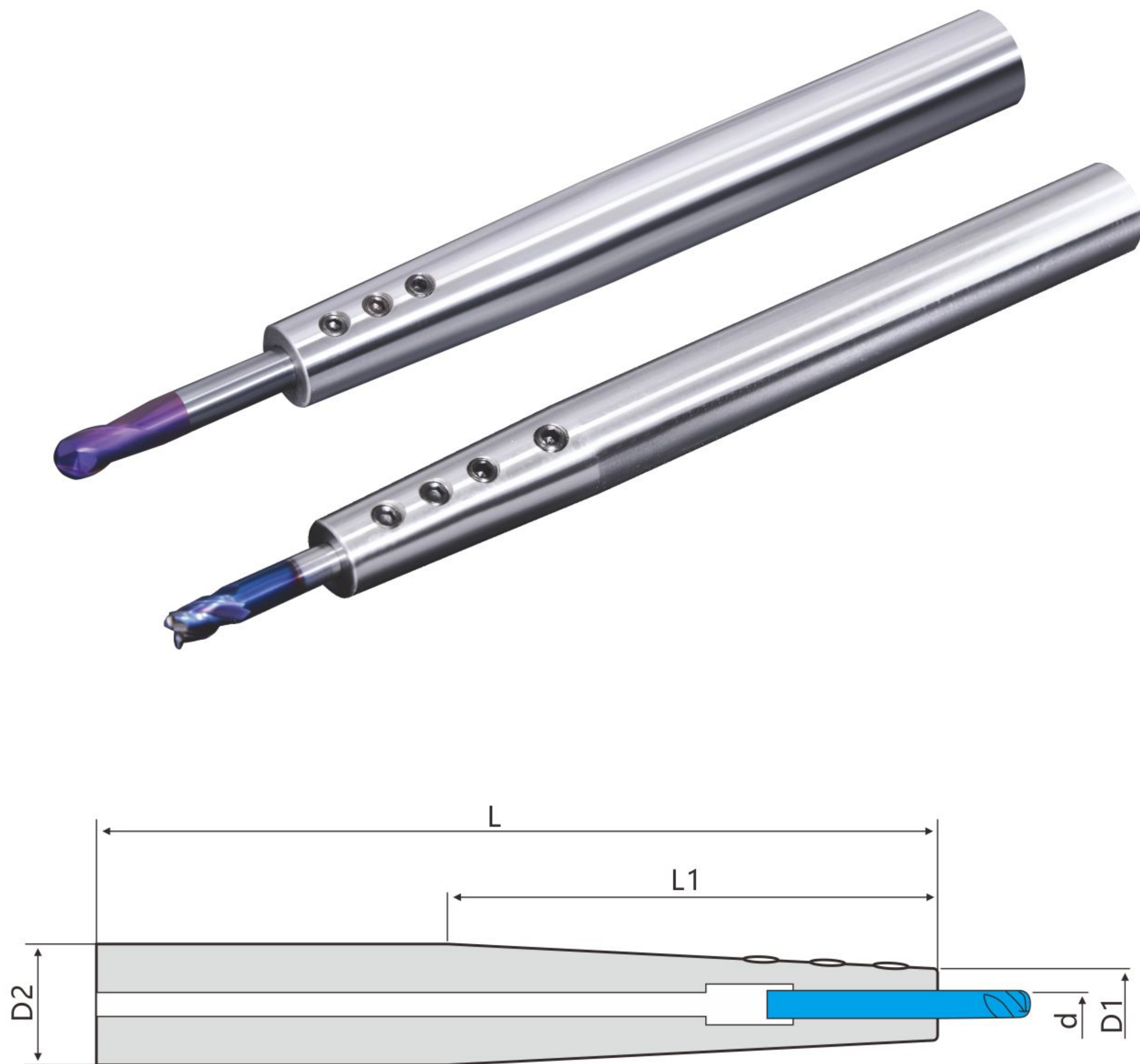

● 库存 Stock

单位：mm

型号	d	D1	D2	L	L1	M螺丝	库存
C10-SL4-100	4	9	10	100	25	M4×0.7	●
C12-SL4-120	4	9.5	12	120	25	M4×0.7	●
C12-SL6-120	6	10.5	12	120	25	M4×0.7	●
C16-SL4-160	4	10	16	160	70	M4×0.7	●
C16-SL6-160	6	12	16	160	70	M4×0.7	●
C16-SL8-160	8	14	16	160	70	M5×0.8	●
C16-SL6-200	6	12	16	200	70	M4×0.7	●
C16-SL8-200	8	14	16	200	70	M5×0.8	●
C20-SL8-160	8	14	20	160	70	M5×0.8	●
C20-SL10-160	10	17	20	160	70	M5×0.8	●
C20-SL12-160	12	19	20	160	70	M5×0.8	●
C20-SL6-200	6	12	20	200	70	M5×0.8	○
C20-SL8-200	8	14	20	200	70	M5×0.8	●
C20-SL10-200	10	17	20	200	70	M5×0.8	●
C20-SL12-200	12	19	20	200	70	M5×0.8	●

强力刀柄

- 强劲的夹紧力实现高速重切削及最佳的精切削
- 内径入口部3mm以下完美夹持
- 稳定的螺母 夹紧及脱紧扭矩，在更换安装刀具时实现稳定性能

MAS	Taper Accuracy	G Value	RPM	Coolant System
-BT	AT3			

● 库存 Stock

单位: mm

	型号	d	D1	L	L1	重量(kg)	库存
30	BT30-MLC20-80	20	54	80	70	1.15	○
	BT30-MLC25-80	25	62.5	80	80	1.48	○
40	BT40-MLC20-105	20	54	105	70	1.77	○
	BT40-MLC25-105	25	62.5	105	80	2.10	○
	BT40-MLC32-105	32	74	105	100	2.40	●
	BT40-MLC32-135	32	74	135	100	3.10	○
50	BT50-MLC32-105	32	74	105	100	4.30	●
	BT50-MLC32-135	32	74	135	100	4.90	○
	BT50-MLC32-165	32	74	165	100	5.60	●
	BT50-MLC42-115	42	92	115	110	4.60	○
A63	HSK A63-MLC20-105	20	54	105	70	1.50	○
	HSK A63-MLC25-120	25	62.5	120	80	2.20	○
	HSK A63-MLC32-130	32	74	130	100	2.70	○
A100	HSK A100-MLC20-110	20	54	110	70	3.50	○
	HSK A100-MLC25-130	25	62.5	130	80	3.80	○
	HSK A100-MLC32-135	32	74	135	100	4.20	○
	HSK A100-MLC42-135	42	74	135	100	5.30	○

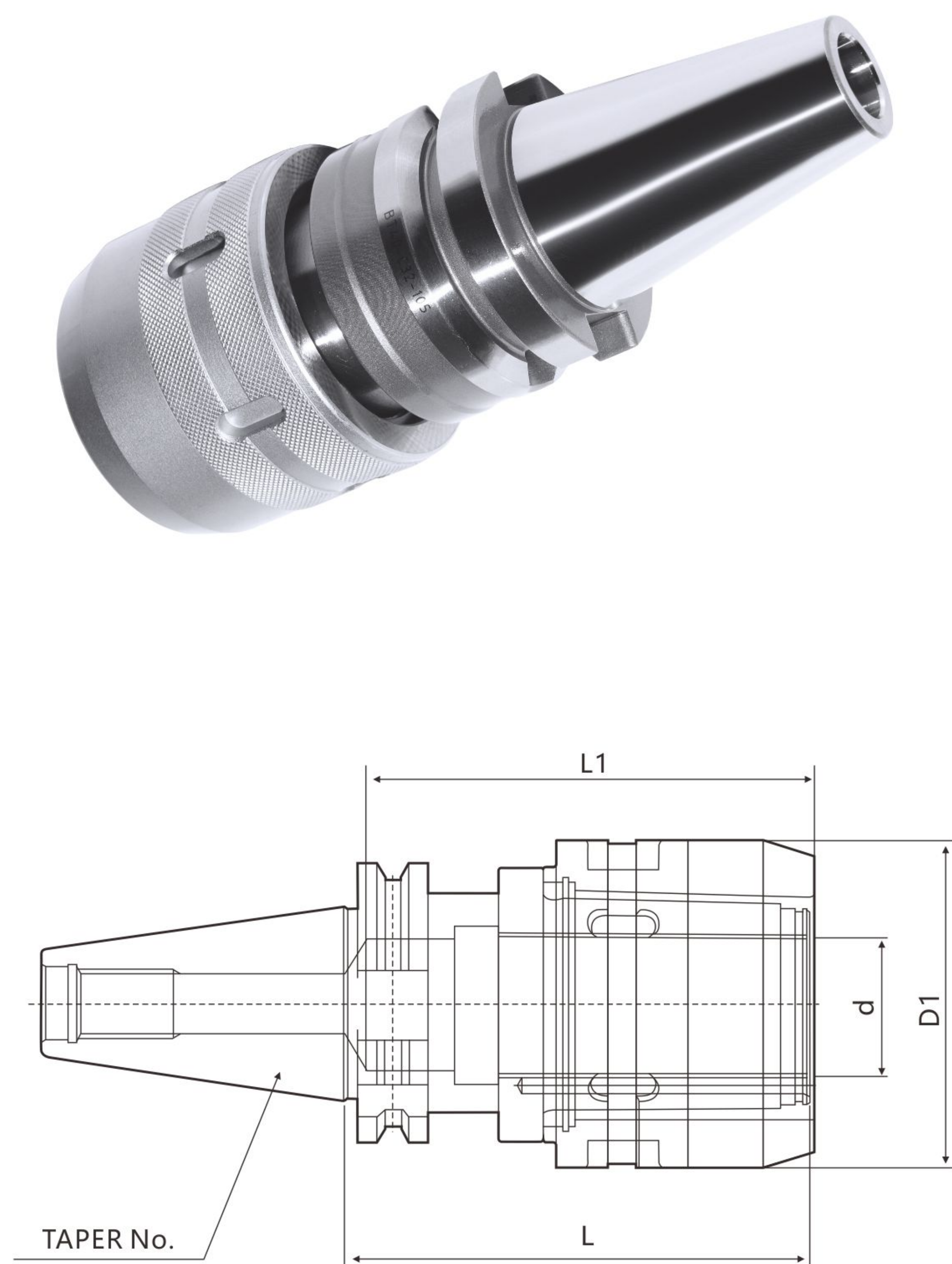

强力弹性直筒夹

强力弹性直筒夹	型号	Run-out(跳动)	库存
	SC20-4,6,8,10,12,16	(3×D) 0~0.015	○
	SC25-4,6,8,10,12,16,20	(3×D) 0~0.015	●
	SC32-4,6,8,10,12,16,19,20,24,25	(3×D) 0~0.015	●
	SC42-4,6,8,10,12,16,20,25,32	(3×D) 0~0.015	○

高速强力刀柄

- 强劲的夹紧力实现高速重切削及最佳的精切削
- 内径入口部3mm以下完美夹持
- 稳定的螺母 夹紧及脱紧扭矩，在更换安装刀具时实现稳定性能

DIN 69893	Taper Accuracy	G Value	RPM	Coolant System
-HSK	AT3	6.3	20000	

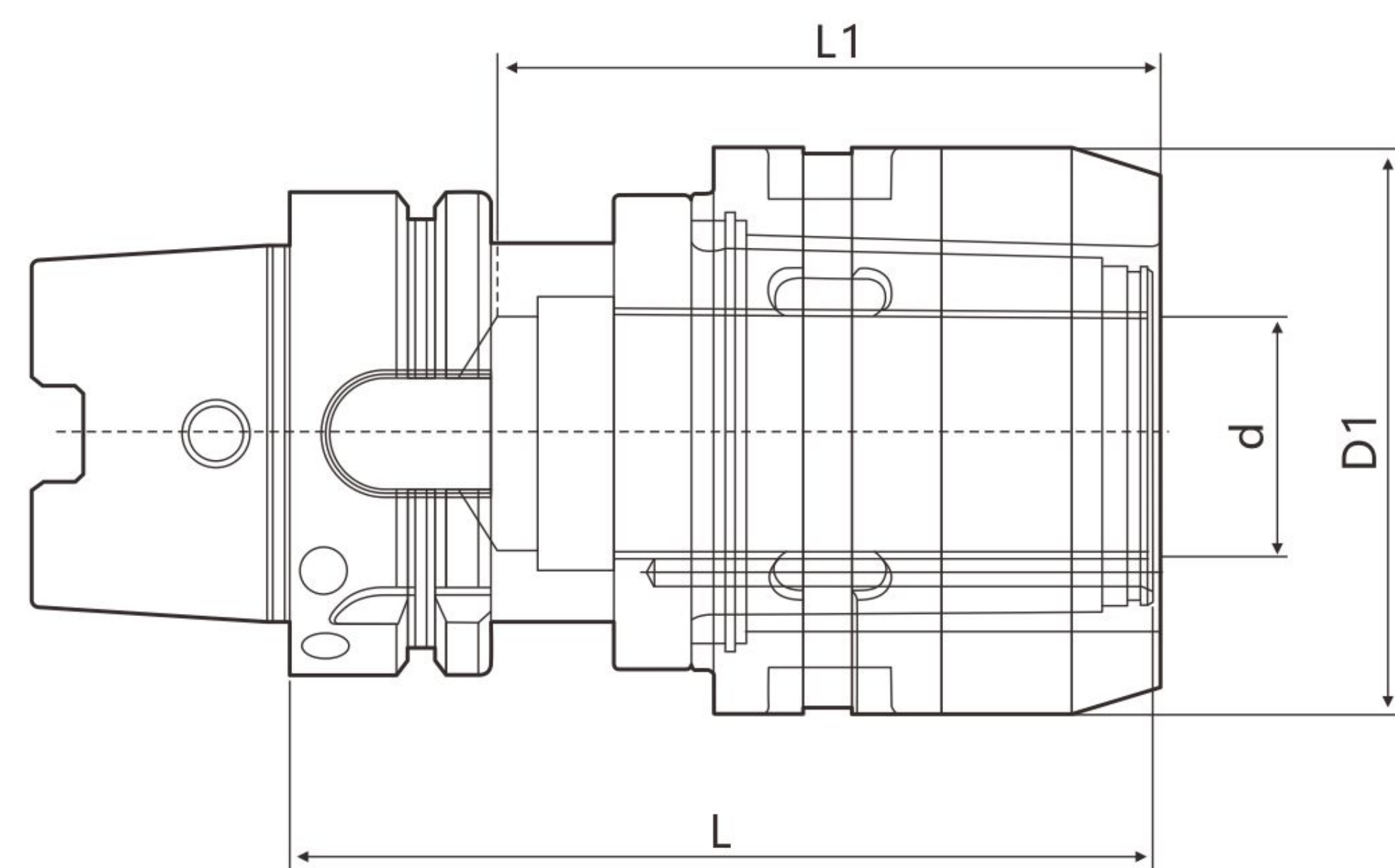

● 库存 Stock

单位: mm

	型号	d	D1	L	L1	重量(kg)	库存
30	BT30-MLC20-80 HS	20	54	80	70	1.15	○
	BT30-MLC25-80 HS	25	62.5	80	80	1.48	○
40	BT40-MLC20-105 HS	20	54	105	70	1.77	○
	BT40-MLC25-105 HS	25	62.5	105	80	2.10	●
	BT40-MLC32-105 HS	32	74	105	100	2.40	●
	BT40-MLC32-135 HS	32	74	135	100	3.10	○
50	BT50-MLC32-105 HS	32	74	105	100	4.30	○
	BT50-MLC32-135 HS	32	74	135	100	4.90	○
	BT50-MLC32-165 HS	32	74	165	100	5.60	○
	BT50-MLC42-115 HS	42	92	115	110	4.60	○
A63	HSK A63-MLC20-105 HS	20	54	105	70	1.50	○
	HSK A63-MLC25-120 HS	25	62.5	120	80	2.20	●
	HSK A63-MLC32-130 HS	32	74	130	100	2.70	●
	HSK A63-HPC25-110 GS	25	61	110	84	2.00	○
	HSK A63-HPC25-145 GS	25	61	145	119	2.60	○
	HSK A63-HPC32-110 GS	32	70.5	110	84	2.20	●
	HSK A63-HPC32-145 GS	32	70.5	145	119	2.90	○
A100	HSK A100-MLC20-110 HS	20	54	110	70	3.50	○
	HSK A100-MLC25-130 HS	25	62.5	130	80	3.80	○
	HSK A100-MLC32-135 HS	32	74	135	100	4.20	○
	HSK A100-MLC42-135 HS	42	74	135	100	5.30	○

■ 高精度强力弹性直筒夹

强力弹性直筒夹	型号	Run-out(跳动)	库存
	SC20-4,6,8,10,12,16A	(3×D) 0~0.01	○
	SC25-4,6,8,10,12,16,20A	(3×D) 0~0.01	●
	SC32-4,6,8,10,12,16,20,25A	(3×D) 0~0.01	●
	SC42-4,6,8,10,12,16,20,25,32A	(3×D) 0~0.01	○

平刀系列 EGS/EMS

- EG HRC25~52
- EM HRC35~60

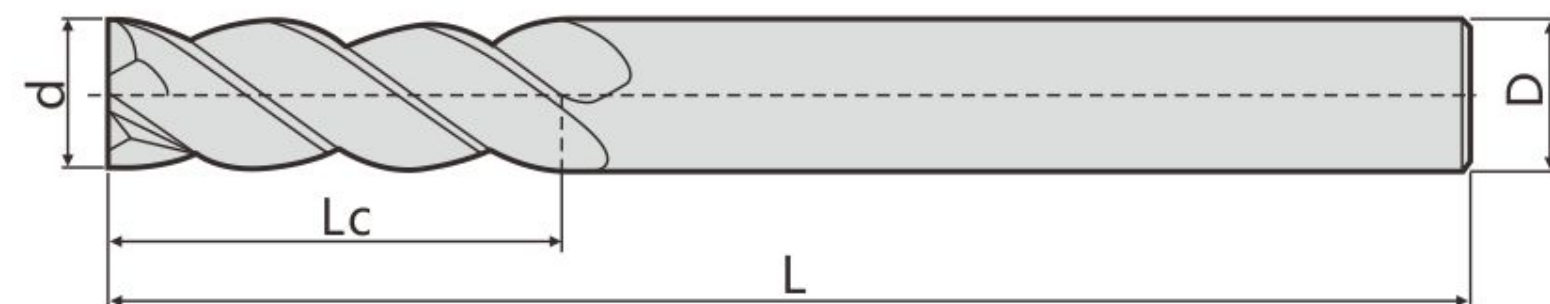

• 库存 Stock

单位: mm

型号	d	R	Lc	L	D	库存
0.2×4D×50	0.2			50	4	●
0.3×4D×50	0.3			50	4	●
0.4×4D×50	0.4			50	4	●
0.5×4D×50	0.5			50	4	●
0.6×4D×50	0.6			50	4	●
0.7×4D×50	0.7			50	4	●
0.8×4D×50	0.8			50	4	●
0.9×4D×50	0.9			50	4	○
1×3×4D×50	1		3	50	4	●
1.5×4×4D×50	1.5		4	50	4	●
2×6×4D×50	2		6	50	4	●
2.5×8×4D×50	2.5		8	50	4	●
3×9×4D×50	3		9	50	4	●
4×11×4D×50	4		11	50	4	●
5×13×6D×50	5		13	50	6	●
6×16×6D×50	6		16	50	6	●
8×20×8D×60	8		20	50	8	●
10×25×10D×75	10		25	75	10	●
12×30×12D×75	12		30	75	12	●
14×34×16D×100	14		34	100	16	○
16×40×16D×100	16		40	100	16	●
20×45×20D×100	20		45	100	20	○
4×11×4D×75	4		11	75	4	●
6×16×6D×75	6		16	75	6	●
8×20×8D×75	8		20	75	8	●
4×11×4D×100	4		11	100	4	○
6×16×6D×100	6		16	100	6	●
8×20×8D×100	8		20	100	8	●
10×25×10D×100	10		25	100	10	●
12×30×12D×100	12		30	100	12	●
16×40×16D×150	16		40	150	16	○
20×45×20D×150	20		45	150	20	○

球刀系列 EGB/EMB

- EG HRC25~52
- EM HRC35~60

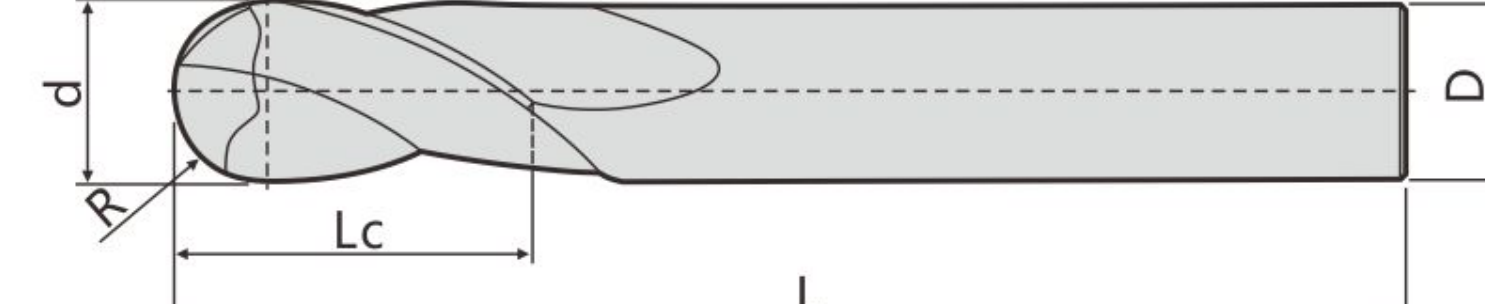

• 库存 Stock

单位: mm

型号	d	R	Lc	L	D	库存
R0.15×4D×50	0.3	0.15		50	4	●
R0.2×4D×50	0.4	0.2		50	4	●
R0.25×4D×50	0.5	0.25		50	4	●
R0.3×4D×50	0.6	0.3		50	4	●
R0.35×4D×50	0.7	0.35		50	4	●
R0.4×4D×50	0.8	0.4		50	4	●
R0.45×4D×50	0.9	0.45		50	4	●
R0.5×4D×50	1	0.5	2	50	4	●
R0.75×4D×50	1.5	0.75	3	50	4	●
R1×4D×50	2	1	4	50	4	●
R1.25×4D×50	2.5	1.25	5	50	4	○
R1.5×4D×50	3	1.5	6	50	4	●
R2×4D×50	4	2	8	50	4	●
R2.5×6D×50	5	2.5	10	50	6	○
R3×6D×50	6	3	12	50	6	●
R3×6D×60	6	3	12	60	6	○
R4×8D×60	8	4	13	50	8	●
R5×10D×75	10	5	18	75	10	●
R6×12D×75	12	6	22	75	12	●
R8×16D×100	16	8	30	100	16	○
R10×20D×100	20	10	38	100	20	○
R2×4D×75	4	2	8	75	4	○
R3×6D×75	6	3	12	75	6	●
R4×8D×75	8	4	13	75	8	●
R2×4D×100	4	2	8	100	4	○
R3×6D×100	6	3	12	100	6	○
R4×8D×100	8	4	13	100	8	●
R5×10D×100	10	5	18	100	10	●
R6×12D×100	12	6	22	100	12	○

圆鼻刀系列 EGR/EMR

深沟平刀系列 EGDS/EMDS

- EG HRC25~52
- EM HRC35~60

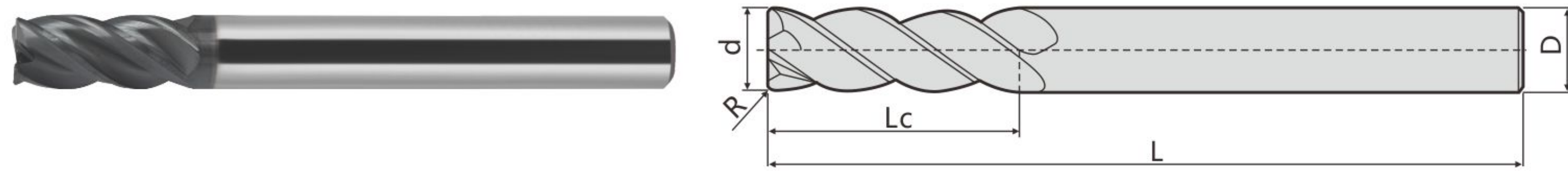

- EG HRC25~52
- EM HRC35~60

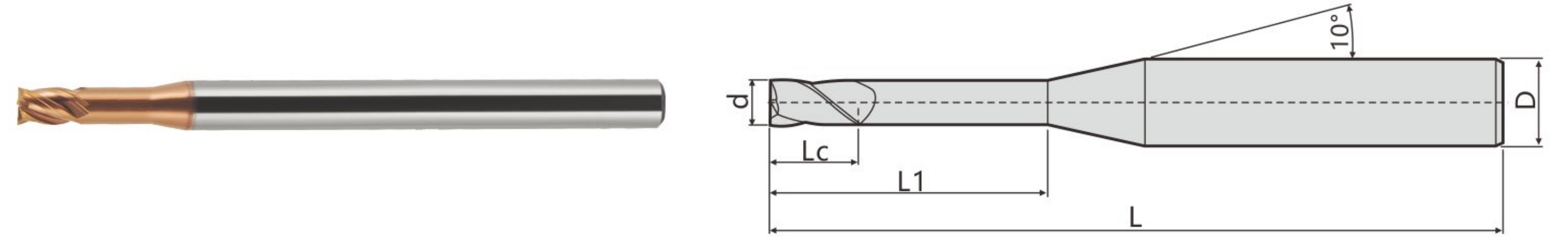

• 库存 Stock

单位: mm

型号	d	R	Lc	L	D	库存
1R0.2×4D×50	1	0.2	2	50	4	●
1.5R0.2×4D×50	1.5	0.2	3	50	4	●
2R0.2×4D×50	2	0.2	4	50	4	●
3R0.2×4D×50	3	0.2	6	50	4	●
4R0.2×4D×50	4	0.2	8	50	4	●
2R0.5×4D×50	2	0.5	4	50	4	●
3R0.5×4D×50	3	0.5	6	50	4	●
4R0.5×4D×50	4	0.5	8	50	4	●
6R0.5×6D×50	6	0.5	12	50	6	●
6R0.5×6D×60	6	0.5	12	60	6	●
8R0.5×8D×60	8	0.5	16	60	8	●
10R0.5×10D×75	10	0.5	20	75	10	●
12R0.5×12D×75	12	0.5	24	75	12	●
4R0.5×4D×75	4	0.5	8	75	4	●
6R0.5×6D×75	6	0.5	12	75	6	●
8R0.5×8D×75	8	0.5	16	75	8	●
6R0.5×6D×100	6	0.5	12	100	6	●
8R0.5×8D×100	8	0.5	16	100	8	●
10R0.5×10D×100	10	0.5	20	100	10	●
12R0.5×12D×100	12	0.5	24	100	12	●
4R1×4D×50	4	1	8	50	4	●
6R1×6D×50	6	1	12	50	6	●
6R1×6D×60	6	1	12	60	6	●
8R1×8D×60	8	1	16	60	8	●
10R1×10D×75	10	1	20	75	10	●
12R1×12D×75	12	1	24	75	12	●
6R1×6D×75	6	1	12	75	6	●
8R1×8D×75	8	1	16	75	8	●
6R1×6D×100	6	1	12	100	6	●
8R1×8D×100	8	1	16	100	8	●
10R1×10D×100	10	1	20	100	10	●
12R1×12D×100	12	1	24	100	12	●

• 库存 Stock

单位: mm

型号	d	R	Lc	L1	L	D	库存
1×4D×50 04	1		1.5	4	50	4	○
1×4D×50 06	1		1.5	6	50	4	○
1.5×4D×50 06	1.5		2.2	6	50	4	○
1.5×4D×50 08	1.5		2.2	8	50	4	○
2×4D×50 06	2		3	6	50	4	○
2×4D×50 08	2		3	8	50	4	○
2×4D×50 10	2		3	10	50	4	○
3×4D×50 10	3		4	10	50	4	○
1×6D×50 04	1		1.5	4	50	6	○
1×6D×50 06	1		1.5	6	50	6	○
1.5×6D×50 06	1.5		2.2	6	50	6	○
1.5×6D×50 08	1.5		2.2	8	50	6	○
2×6D×50 06	2		3	6	50	6	○
2×6D×50 08	2		3	8	50	6	○
2×6D×50 10	2		3	10	50	6	○
4×6D×50 12	4		6	12	50	6	○
3×6D×60 15	3		4	15	60	6	○
4×6D×60 12	4		6	12	60	6	○
4×6D×60 16	4		6	16	60	6	○
4×6D×60 20	4		6	20	60	6	○

深沟球刀系列 EGDB/EMDB

深沟圆鼻刀系列 EGDR/EMDR

- EG HRC25~52
- EM HRC35~60

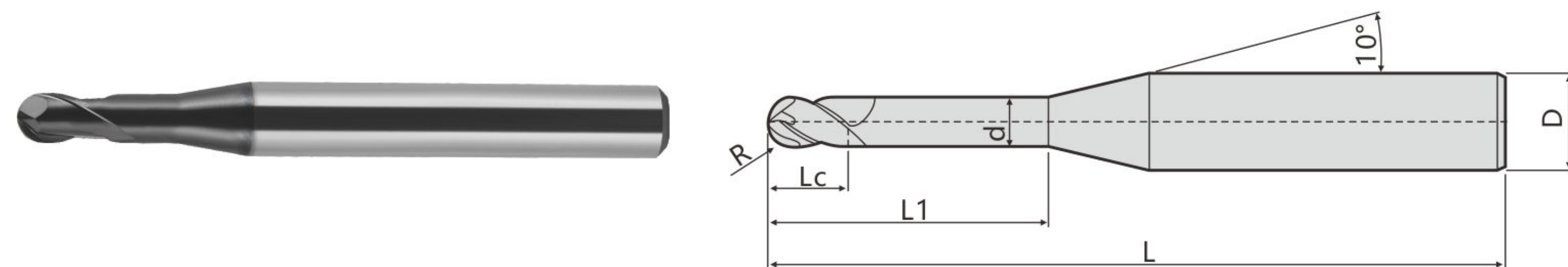

● 库存 Stock

单位: mm

型号	d	R	Lc	L1	L	D	库存
R0.5×4D×50 04	1	0.5	1.2	4	50	4	●
R0.5×4D×50 06	1	0.5	1.2	6	50	4	●
R0.75×4D×50 06	1.5	0.75	1.8	6	50	4	●
R0.75×4D×50 08	1.5	0.75	1.8	8	50	4	●
R1×4D×50 06	2	1	2.2	6	50	4	●
R1×4D×50 08	2	1	2.2	8	50	4	●
R1×4D×50 10	2	1	2.2	10	50	4	●
R1.5×4D×50 10	3	1.5	3.6	10	50	4	●
R0.5×6D×50 04	1	0.5	1.2	4	50	6	●
R0.5×6D×50 06	1	0.5	1.2	6	50	6	●
R0.75×6D×50 06	1.5	0.75	1.8	6	50	6	●
R0.75×6D×50 08	1.5	0.75	1.8	8	50	6	●
R1×6D×50 06	2	1	2.2	6	50	6	●
R1×6D×50 08	2	1	2.2	8	50	6	●
R1×6D×50 10	2	1	2.2	10	50	6	●
R2×6D×50 12	4	2	5	12	50	6	●
R1.5×6D×60 15	3	1.5	3.6	15	60	6	●
R2×6D×60 12	4	2	5	12	60	6	●
R2×6D×60 16	4	2	5	16	60	6	●
R2×6D×60 20	4	2	5	20	60	6	●

- EG HRC25~52
- EM HRC35~60

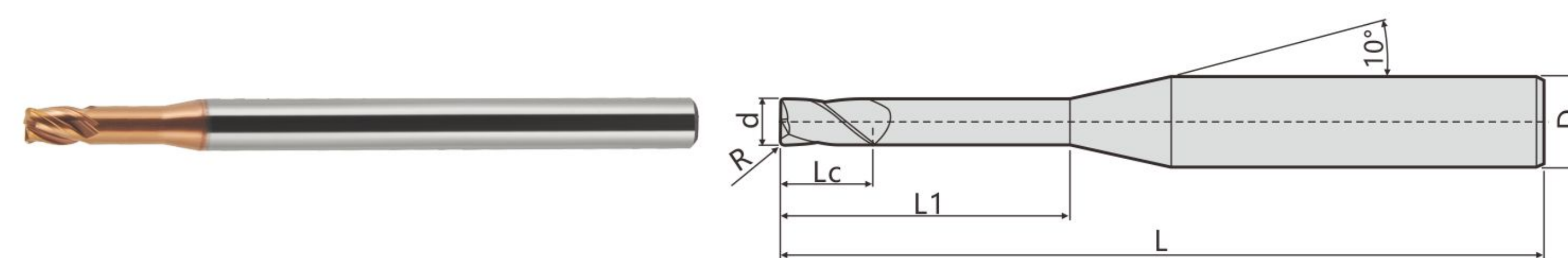

● 库存 Stock

单位: mm

型号	d	R	Lc	L1	L	D	库存
1R0.2×4D×50 04	1	0.2	1.5	4	50	4	●
1R0.2×4D×50 06	1	0.2	1.5	6	50	4	●
1.5R0.2×4D×50 06	1.5	0.2	2.2	6	50	4	●
1.5R0.2×4D×50 08	1.5	0.2	2.2	8	50	4	●
2R0.2×4D×50 06	2	0.2	3	6	50	4	●
2R0.2×4D×50 08	2	0.2	3	8	50	4	●
2R0.2×4D×50 10	2	0.2	3	10	50	4	●
3R0.2×4D×50 10	3	0.2	4	10	50	4	●
2R0.5×4D×50 06	2	0.5	3	6	50	4	●
2R0.5×4D×50 08	2	0.5	3	8	50	4	●
2R0.5×4D×50 10	2	0.5	3	10	50	4	●
3R0.5×4D×50 10	3	0.5	4	10	50	4	●
3R0.5×6D×60 15	3	0.5	4	15	60	6	●
4R0.5×6D×60 16	4	0.5	6	16	60	6	●
4R0.5×6D×60 20	4	0.5	6	20	60	6	●

精品ES平刀通用系列 HRC50度以内

精品ES球刀通用系列 HRC50度以内

● ESS 平刀耐磨型

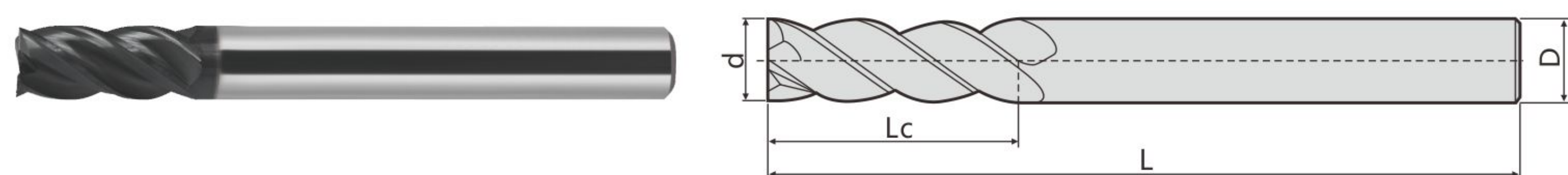

● ESB 球刀耐磨型

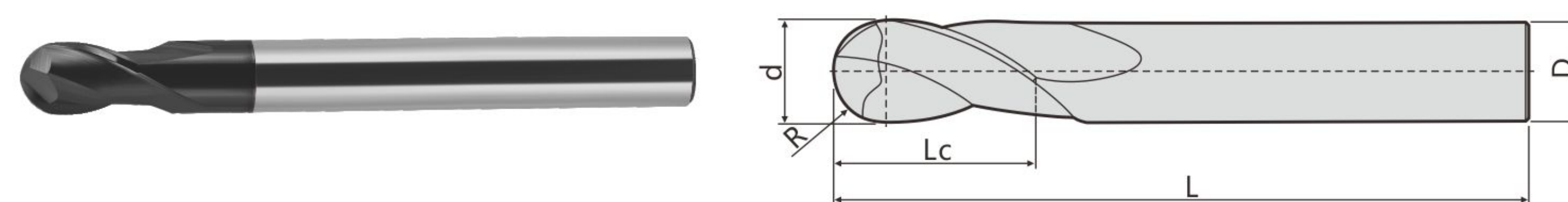

● 库存 Stock

单位: mm

型号	d	R	Lc	L	D	库存
ESS2002 0.2×50	0.2			50	4	○
ESS2003 0.3×50	0.3			50	4	○
ESS2004 0.4×50	0.4			50	4	○
ESS2005 0.5×50	0.5			50	4	○
ESS2006 0.6×50	0.6			50	4	○
ESS2007 0.7×50	0.7			50	4	○
ESS2008 0.8×50	0.8			50	4	○
ESS2009 0.9×50	0.9			50	4	○
ESS4010 1×50	1		3	50	4	○
ESS4015 1.5×50	1.5		4	50	4	○
ESS4020 2×50	2		6	50	4	○
ESS4025 2.5×50	2.5		8	50	4	○
ESS4030 3×50	3		9	50	4	○
ESS4040 4×50	4		11	50	4	○
ESS4060 6×50	6		16	50	6	○
ESS4060 6×60	6		16	60	6	○
ESS4080 8×60	8		20	60	8	○
ESS4100 10×75	10		25	75	10	○
ESS4120 12×75	12		30	75	12	○
ESS4160 16×100	16		40	100	16	○
ESS4200 20×100	20		45	100	20	○
ESHS4040 4×75	4		11	75	4	○
ESHS4060 6×75	6		16	75	6	○
ESHS4080 8×75	8		20	75	8	○
ESHHS4080 8×100	8		20	100	8	○
ESHS4100 10×100	10		25	100	10	○
ESHS4120 12×100	12		30	100	12	○

● 库存 Stock

单位: mm

型号	d	R	Lc	L	D	库存
ESB2002 R0.1×50	0.2	0.1		50	4	○
ESB2003 R0.15×50	0.3	0.15		50	4	○
ESB2004 R0.2×50	0.4	0.2		50	4	○
ESB2005 R0.25×50	0.5	0.25		50	4	●
ESB2006 R0.3×50	0.6	0.3		50	4	●
ESB2007 R0.35×50	0.7	0.35		50	4	●
ESB2008 R0.4×50	0.8	0.4		50	4	●
ESB2009 R0.45×50	0.9	0.45		50	4	●
ESB2010 R0.5×50	1	0.5	2	50	4	●
ESB2015 R0.75×50	1.5	0.75	3	50	4	●
ESB2020 R1×50	2	1	4	50	4	●
ESB2025 R1.25×50	2.5	1.25	5	50	4	○
ESB2030 R1.5×50	3	1.5	6	50	4	●
ESB2040 R2×50	4	2	8	50	4	●
ESB2060 R3×50	6	3	12	50	6	●
ESHB2060 R3×60	6	3	12	60	6	●
ESB2080 R4×60	8	4	13	60	8	●
ESB2100 R5×75	10	5	16	75	10	●
ESB2120 R6×75	12	6	20	75	12	●
ESHB2040 R2×75	4	2	8	75	4	●
ESHB2060 R3×75	6	3	12	75	6	●
ESHB2080 R4×75	8	4	13	75	8	●
ESHHS2080 R4×100	8	4	13	100	8	●
ESHB2100 R5×100	10	5	16	100	10	●
ESHB2120 R6×100	12	6	20	100	12	●

精品ES圆鼻刀通用系列 HRC50度

精品ES深沟平刀通用系列 HRC50度

● ESR 圆鼻刀耐磨型



● 库存 Stock

单位: mm

型号	d	R	Lc	L1	L	D	库存
ESR2008-R0.1	0.8	0.1			50	4	○
ESR2009-R0.1	0.9	0.1			50	4	○
ESR2010-R0.2	1	0.2		2	50	4	●
ESR4015-R0.2	1.5	0.2		3	50	4	●
ESR4020-R0.2	2	0.2		4	50	4	●
ESR4030-R0.2	3	0.2		6	50	4	●
ESR4040-R0.2	4	0.2		8	50	4	●
ESR4060-R0.2	6	0.2		12	50	4	●
ESR4020-R0.5	2	0.5		4	50	4	●
ESR4030-R0.5	3	0.5		6	50	4	●
ESR4040-R0.5	4	0.5		8	50	4	●
ESR4060-R0.5	6	0.5		12	50	6	●
ESR4080-R0.5	8	0.5		16	50	8	●
ESR4100-R0.5	10	0.5		20	50	10	●
ESR4120-R0.5	12	0.5		24	50	12	●
ESHR4060-R0.5-60	6	0.5		12	60	6	●
ESHR4060-R0.5-75	6	0.5		12	75	6	●
ESHR4080-R0.5-75	8	0.5		16	75	8	●
ESHHR4080-R0.5-100	8	0.5		16	100	8	●
ESHR4100-R0.5-100	10	0.5		20	100	10	●
ESHR4120-R0.5-100	12	0.5		24	100	12	●
ESR4040-R1	4	1		8	50	4	●
ESR4060-R1	6	1		12	50	6	●
ESR4080-R1	8	1		16	60	8	●
ESR4100-R1	10	1		20	75	10	●
ESR4120-R1	12	1		24	75	12	●
ESHR4060-R1-60	6	1		12	60	6	●
ESHR4060-R1-75	6	1		12	75	6	●
ESHR4080-R1-75	8	1		16	75	8	●
ESHHR4080-R1-100	8	1		16	100	8	●
ESHR4100-R1-100	10	1		20	100	10	●
ESHR4120-R1-100	12	1		24	100	12	●

● ESDS 深沟平刀耐磨型

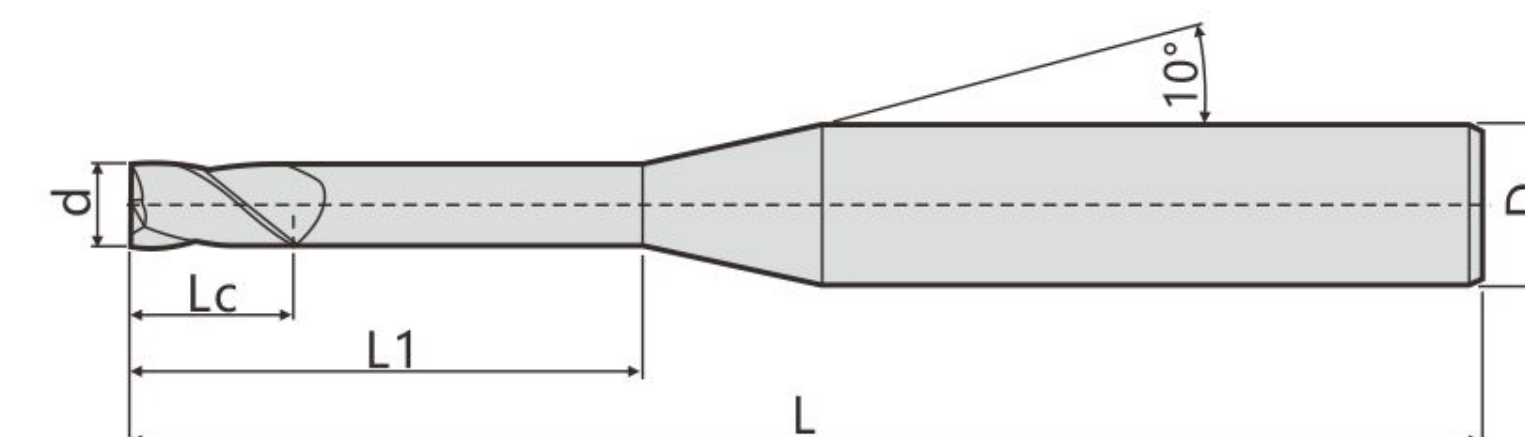

● 库存 Stock

单位: mm

型号	d	R	Lc	L1	L	D	库存
ESDS4010-04-4D	1		1.5	4	50	4	○
ESDS4010-06-4D	1		1.5	6	50	4	○
ESDS4010-08-4D	1		1.5	8	50	4	○
ESDS4015-06-4D	1.5		2.2	6	50	4	○
ESDS4015-08-4D	1.5		2.2	8	50	4	○
ESDS4020-06-4D	2		3	6	50	4	○
ESDS4020-08-4D	2		3	8	50	4	○
ESDS4020-10-4D	2		3	10	50	4	○
ESDS4030-10-4D	3		4	10	50	4	○
ESDS4030-15-6D-60	3		4	15	60	6	○
ESDS4030-20-6D-60	3		4	20	60	6	○
ESDS4040-12-6D-50	4		6	12	60	6	○
ESDS4040-12-6D-60	4		6	12	60	6	○
ESDS4040-16-6D-60	4		6	16	60	6	○
ESDS4040-20-6D-60	4		6	20	60	6	○

精品ES深沟球刀通用系列 HRC50度

精品ES深沟圆鼻刀通用系列 HRC50度

● ESDB 深沟球刀耐磨型

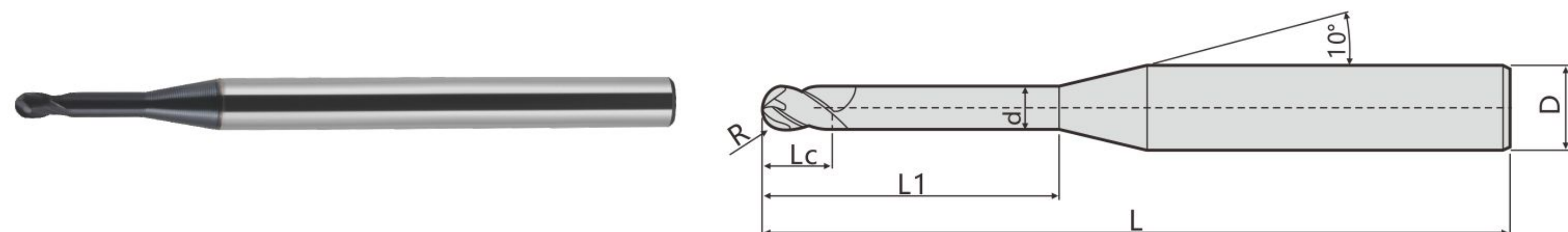

● ESDR 深沟圆鼻刀耐磨型

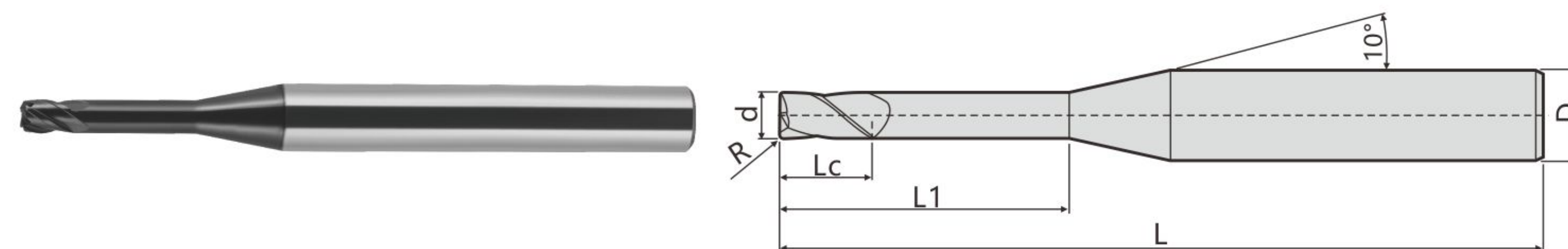

● 库存 Stock

单位: mm

型号	d	R	Lc	L1	L	D	库存
ESDB2010-04-4D	1	0.5	1.2	4	50	4	●
ESDB2010-06-4D	1	0.5	1.2	6	50	4	●
ESDB2010-08-4D	1	0.5	1.2	8	50	4	○
ESDB2015-06-4D	1.5	0.75	1.8	6	50	4	●
ESDB2015-08-4D	1.5	0.75	1.8	8	50	4	●
ESDB2020-06-4D	2	1	2.2	6	50	4	●
ESDB2020-08-4D	2	1	2.2	8	50	4	●
ESDB2020-10-4D	2	1	2.2	10	50	4	●
ESDB2030-10-4D	3	1.5	3.6	10	50	4	●
ESDB2030-15-6D-60	3	1.5	3.6	15	60	6	●
ESDB2030-20-6D-60	3	1.5	3.6	20	60	6	○
ESDB2040-12-6D-50	4	2	5	12	60	6	●
ESDB2040-12-6D-60	4	2	5	12	60	6	○
ESDB2040-16-6D-60	4	2	5	16	60	6	●
ESDB2040-20-6D-60	4	2	5	20	60	6	●

● 库存 Stock

单位: mm

型号	d	R	Lc	L1	L	D	库存
ESDR4010-R0.2-04-4D	1	0.2	1.5	4	50	4	●
ESDR4010-R0.2-06-4D	1	0.2	1.5	6	50	4	●
ESDR4010-R0.2-08-4D	1	0.2	1.5	8	50	4	○
ESDR4015-R0.2-06-4D	1.5	0.2	2.2	6	50	4	●
ESDR4015-R0.2-08-4D	1.5	0.2	2.2	8	50	4	●
ESDR4020-R0.2-06-4D	2	0.2	3	6	50	4	●
ESDR4020-R0.2-08-4D	2	0.2	3	8	50	4	●
ESDR4020-R0.2-10-4D	2	0.2	3	10	50	4	●
ESDR4030-R0.2-10-4D	3	0.2	4	10	50	4	●
ESDR4030-R0.2-15-6D-60	3	0.2	4	15	60	6	○
ESDR4030-R0.2-20-6D-60	3	0.2	4	20	60	6	○
ESDR4040-R0.2-12-6D-50	4	0.2	6	12	60	6	○
ESDR4040-R0.2-12-6D-60	4	0.2	6	12	60	6	○
ESDR4040-R0.2-16-6D-60	4	0.2	6	16	60	6	○
ESDR4040-R0.2-20-6D-60	4	0.2	6	20	60	6	○
ESDR4020-R0.5-06-4D	2	0.5	3	6	50	4	●
ESDR4020-R0.5-08-4D	2	0.5	3	8	50	4	●
ESDR4020-R0.5-10-4D	2	0.5	3	10	50	4	○
ESDR4030-R0.5-10-4D	3	0.5	4	10	50	4	●
ESDR4030-R0.5-15-6D-60	3	0.5	4	15	60	6	●
ESDR4030-R0.5-20-6D-60	3	0.5	4	20	60	6	○
ESDR4040-R0.5-12-6D-50	4	0.5	6	12	60	6	●
ESDR4040-R0.5-12-6D-60	4	0.5	6	12	60	6	○
ESDR4040-R0.5-16-6D-60	4	0.5	6	16	60	6	●
ESDR4040-R0.5-20-6D-60	4	0.5	6	20	60	6	●
ESDR4040-R1-12-6D-50	4	1	6	12	50	6	○
ESDR4040-R1-12-6D-60	4	1	6	12	60	6	○
ESDR4040-R1-16-6D-60	4	1	6	16	60	6	○
ESDR4040-R1-20-6D-60	4	1	6	20	60	6	○

精品EH高硬度平刀系列 HRC40~70度

精品EH高硬度球刀系列 HRC40~70度

● EHS 平刀高硬度

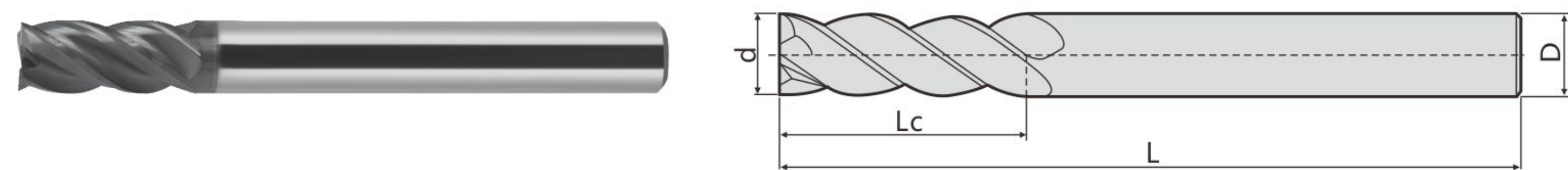

● EHB 球刀高硬度

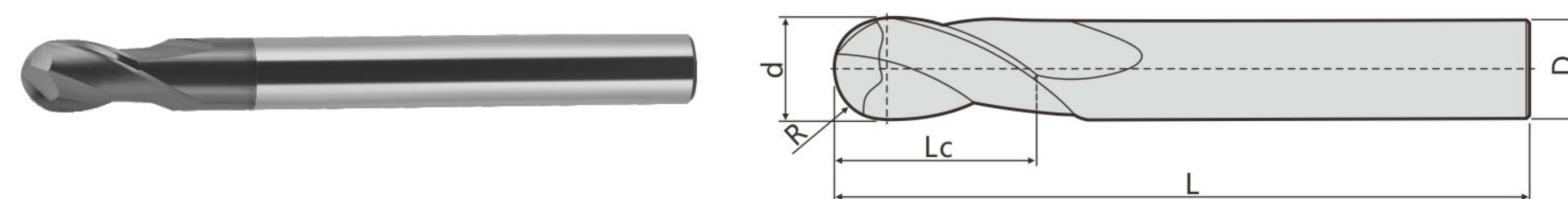

● 库存 Stock

单位: mm

型号	d	R	Lc	L	D	库存
EHS2002 0.2×50	0.2			50	4	○
EHS2003 0.3×50	0.3			50	4	○
EHS2004 0.4×50	0.4			50	4	○
EHS2005 0.5×50	0.5			50	4	○
EHS2006 0.6×50	0.6			50	4	○
EHS2007 0.7×50	0.7			50	4	○
EHS2008 0.8×50	0.8			50	4	○
EHS2009 0.9×50	0.9			50	4	○
EHS4010 1×50	1		3	50	4	○
EHS4015 1.5×50	1.5		4	50	4	○
EHS4020 2×50	2		6	50	4	○
EHS4025 2.5×50	2.5		8	50	4	○
EHS4030 3×50	3		9	50	4	○
EHS4040 4×50	4		11	50	4	○
EHS4060 6×50	6		16	50	6	○
EHS4060 6×60	6		16	60	6	○
EHS4080 8×60	8		20	60	8	○
EHS4100 10×75	10		25	75	10	○
EHS4120 12×75	12		30	75	12	○
EHS4160 16×100	16		40	100	16	○
EHS4200 20×100	20		45	100	20	○
EHHS4040 4×75	4		11	75	4	○
EHHS4060 6×75	6		16	75	6	○
EHHS4080 8×75	8		20	75	8	○
EHHS4080 8×100	8		20	100	8	○
EHHS4100 10×100	10		25	100	10	○
EHHS4120 12×100	12		30	100	12	○

● 库存 Stock

单位: mm

型号	d	R	Lc	L	D	库存
EHB2002 R0.1×50	0.2	0.1		50	4	○
EHB2003 R0.15×50	0.3	0.15		50	4	○
EHB2004 R0.2×50	0.4	0.2		50	4	○
EHB2005 R0.25×50	0.5	0.25		50	4	●
EHB2006 R0.3×50	0.6	0.3		50	4	●
EHB2007 R0.35×50	0.7	0.35		50	4	●
EHB2008 R0.4×50	0.8	0.4		50	4	●
EHB2009 R0.45×50	0.9	0.45		50	4	○
EHB2010 R0.5×50	1	0.5	2	50	4	●
EHB2015 R0.75×50	1.5	0.75	3	50	4	●
EHB2020 R1×50	2	1	4	50	4	●
EHB2025 R1.25×50	2.5	1.25	5	50	4	○
EHB2030 R1.5×50	3	1.5	6	50	4	●
EHB2040 R2×50	4	2	8	50	4	●
EHB2060 R3×50	6	3	12	50	6	●
EHHB2060 R3×60	6	3	12	60	6	●
EHB2080 R4×60	8	4	13	60	8	●
EHB2100 R5×75	10	5	16	75	10	●
EHB2120 R6×75	12	6	20	75	12	●
EHHB2040 R2×75	4	2	8	75	4	○
EHHB2060 R3×75	6	3	12	75	6	●
EHHB2080 R4×75	8	4	13	75	8	●
EHHHB2080 R4×100	8	4	13	100	8	●
EHHB2100 R5×100	10	5	16	100	10	●
EHHB2120 R6×100	12	6	20	100	12	○

精品EH高硬度圆鼻刀系列 HRC40~70度

精品EH深沟平刀高硬度系列 HRC40~70度

● EHR 圆鼻刀高硬度

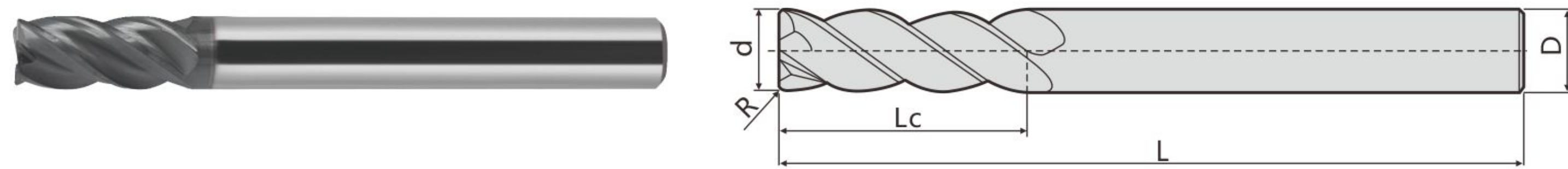

● EHDS 深沟平刀高硬度

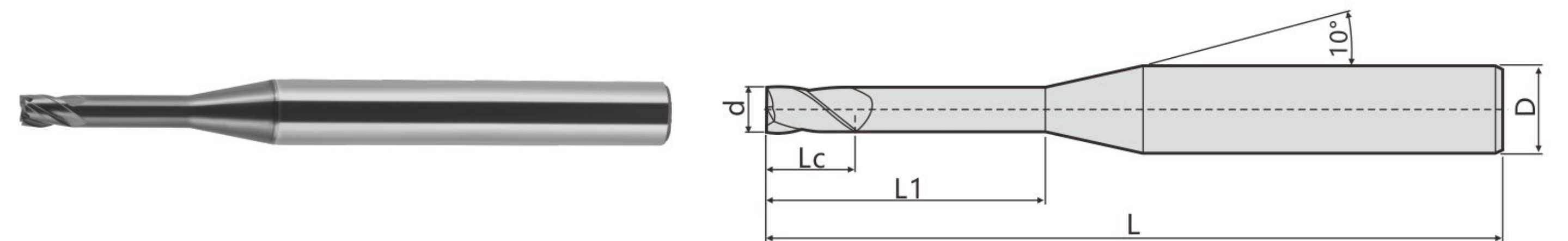

● 库存 Stock

单位: mm

型号	d	R	Lc	L	D	库存
EHR2008-R0.1	0.8	0.1		50	4	○
EHR2009-R0.1	0.9	0.1		50	4	○
EHR2010-R0.2	1	0.2	2	50	4	●
EHR4015-R0.2	1.5	0.2	3	50	4	●
EHR4020-R0.2	2	0.2	4	50	4	●
EHR4030-R0.2	3	0.2	6	50	4	●
EHR4040-R0.2	4	0.2	8	50	4	●
EHR4060-R0.2	6	0.2	12	50	4	●
EHR4020-R0.5	2	0.5	4	50	4	●
EHR4030-R0.5	3	0.5	6	50	4	●
EHR4040-R0.5	4	0.5	8	50	4	●
EHR4060-R0.5	6	0.5	12	50	6	●
EHR4080-R0.5	8	0.5	16	50	8	●
EHR4100-R0.5	10	0.5	20	50	10	●
EHR4120-R0.5	12	0.5	24	50	12	●
EHHR4060-R0.5-60	6	0.5	12	60	6	●
EHHR4060-R0.5-75	6	0.5	12	75	6	●
EHHR4080-R0.5-75	8	0.5	16	75	8	●
EHHR4080-R0.5-100	8	0.5	16	100	8	●
EHHR4100-R0.5-100	10	0.5	20	100	10	●
EHHR4120-R0.5-100	12	0.5	24	100	12	●
EHR4040-R1	4	1	8	50	4	●
EHR4060-R1	6	1	12	50	6	●
EHR4080-R1	8	1	16	60	8	●
EHR4100-R1	10	1	20	75	10	●
EHR4120-R1	12	1	24	75	12	●
EHHR4060-R1-60	6	1	12	60	6	●
EHHR4060-R1-75	6	1	12	75	6	●
EHHR4080-R1-75	8	1	16	75	8	●
EHHR4080-R1-100	8	1	16	100	8	●
EHHR4100-R1-100	10	1	20	100	10	●
EHHR4120-R1-100	12	1	24	100	12	●

● 库存 Stock

单位: mm

型号	d	R	Lc	L1	L	D	库存
EHDS4010-04-4D	1		1.5	4	50	4	○
EHDS4010-06-4D	1		1.5	6	50	4	○
EHDS4010-08-4D	1		1.5	8	50	4	○
EHDS4015-06-4D	1.5		2.2	6	50	4	○
EHDS4015-08-4D	1.5		2.2	8	50	4	○
EHDS4020-06-4D	2		3	6	50	4	○
EHDS4020-08-4D	2		3	8	50	4	○
EHDS4020-10-4D	2		3	10	50	4	○
EHDS4030-10-4D	3		4	10	50	4	○
EHDS4030-15-6D-60	3		4	15	60	6	○
EHDS4030-20-6D-60	3		4	20	60	6	○
EHDS4040-12-6D-50	4		6	12	60	6	○
EHDS4040-12-6D-60	4		6	12	60	6	○
EHDS4040-16-6D-60	4		6	16	60	6	○
EHDS4040-20-6D-60	4		6	20	60	6	○

精品EH深沟球刀高硬度系列 HRC40~70度

精品EH深沟圆鼻刀高硬度系列 HRC40~70度

● EHDB 深沟球刀高硬度

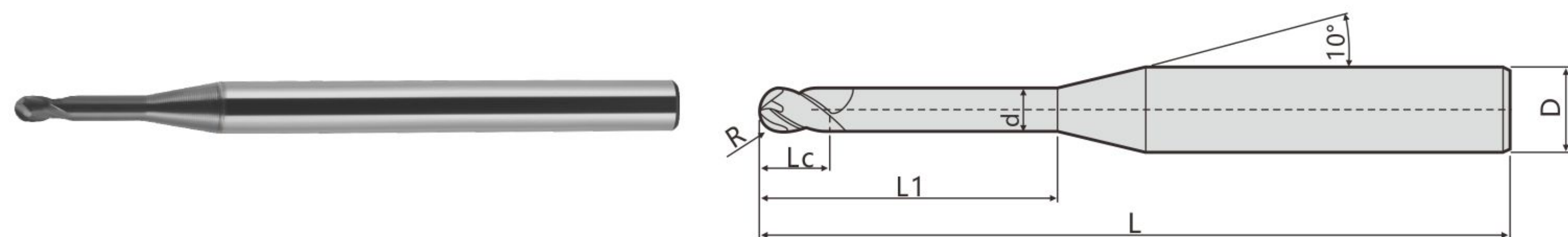

● 库存 Stock

单位: mm

型号	d	R	Lc	L1	L	D	库存
EHDB2010-04-4D	1	0.5	1.2	4	50	4	●
EHDB2010-06-4D	1	0.5	1.2	6	50	4	●
EHDB2010-08-4D	1	0.5	1.2	8	50	4	○
EHDB2015-06-4D	1.5	0.75	1.8	6	50	4	●
EHDB2015-08-4D	1.5	0.75	1.8	8	50	4	●
EHDB2020-06-4D	2	1	2.2	6	50	4	●
EHDB2020-08-4D	2	1	2.2	8	50	4	●
EHDB2020-10-4D	2	1	2.2	10	50	4	●
EHDB2030-10-4D	3	1.5	3.6	10	50	4	●
EHDB2030-15-6D-60	3	1.5	3.6	15	60	6	●
EHDB2030-20-6D-60	3	1.5	3.6	20	60	6	○
EHDB2040-12-6D-50	4	2	5	12	60	6	●
EHDB2040-12-6D-60	4	2	5	12	60	6	○
EHDB2040-16-6D-60	4	2	5	16	60	6	●
EHDB2040-20-6D-60	4	2	5	20	60	6	●

● EHDR 深沟圆鼻刀高硬度

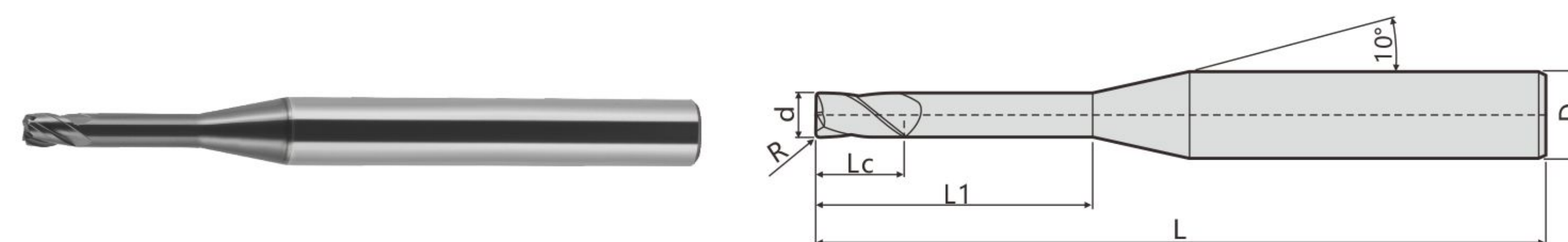

● 库存 Stock

单位: mm

型号	d	R	Lc	L1	L	D	库存
EHDR4010-R0.2-04-4D	1	0.2	1.5	4	50	4	●
EHDR4010-R0.2-06-4D	1	0.2	1.5	6	50	4	●
EHDR4010-R0.2-08-4D	1	0.2	1.5	8	50	4	○
EHDR4015-R0.2-06-4D	1.5	0.2	2.2	6	50	4	●
EHDR4015-R0.2-08-4D	1.5	0.2	2.2	8	50	4	●
EHDR4020-R0.2-06-4D	2	0.2	3	6	50	4	●
EHDR4020-R0.2-08-4D	2	0.2	3	8	50	4	●
EHDR4020-R0.2-10-4D	2	0.2	3	10	50	4	●
EHDR4030-R0.2-10-4D	3	0.2	4	10	50	4	●
EHDR4030-R0.2-15-6D-60	3	0.2	4	15	60	6	○
EHDR4030-R0.2-20-6D-60	3	0.2	4	20	60	6	○
EHDR4040-R0.2-12-6D-50	4	0.2	6	12	60	6	○
EHDR4040-R0.2-12-6D-60	4	0.2	6	12	60	6	○
EHDR4040-R0.2-16-6D-60	4	0.2	6	16	60	6	○
EHDR4040-R0.2-20-6D-60	4	0.2	6	20	60	6	○
EHDR4020-R0.5-06-4D	2	0.5	3	6	50	4	●
EHDR4020-R0.5-08-4D	2	0.5	3	8	50	4	●
EHDR4020-R0.5-10-4D	2	0.5	3	10	50	4	○
EHDR4030-R0.5-10-4D	3	0.5	4	10	50	4	●
EHDR4030-R0.5-15-6D-60	3	0.5	4	15	60	6	●
EHDR4030-R0.5-20-6D-60	3	0.5	4	20	60	6	○
EHDR4040-R0.5-12-6D-50	4	0.5	6	12	60	6	●
EHDR4040-R0.5-12-6D-60	4	0.5	6	12	60	6	○
EHDR4040-R0.5-16-6D-60	4	0.5	6	16	60	6	●
EHDR4040-R0.5-20-6D-60	4	0.5	6	20	60	6	●
EHDR4040-R1-12-6D-50	4	1	6	12	50	6	○
EHDR4040-R1-12-6D-60	4	1	6	12	60	6	○
EHDR4040-R1-16-6D-60	4	1	6	16	60	6	○
EHDR4040-R1-20-6D-60	4	1	6	20	60	6	○

硬质合金抗震刀杆

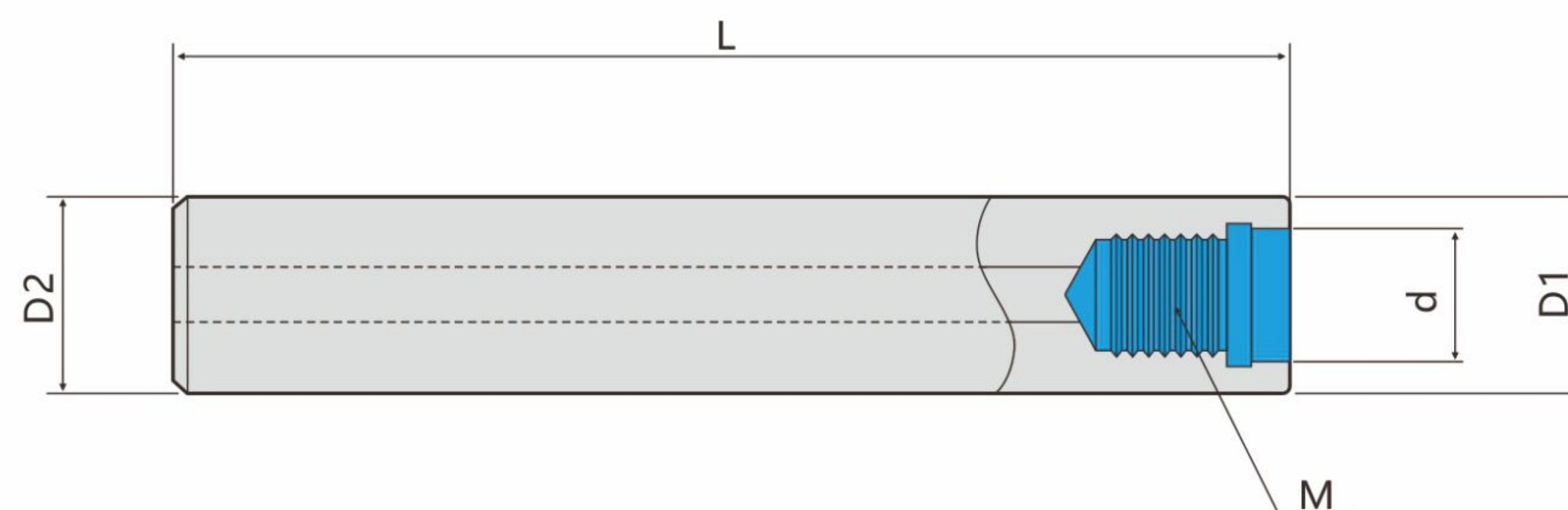

● 库存 Stock

单位: mm

型号	d	M	D1	D2	L	库存
MFT08-100-M4	4.5	M4	8	8	100	●
MFT 10-100-M5	5.5	M5	10	10	100	●
MFT 10-120-M5	5.5	M5	10	10	120	●
MFT 10-150-M5	5.5	M5	10	10	150	●
MFT 10-100-M6	6.5	M6	10	10	100	●
MFT 10-150-M6	6.5	M6	10	10	150	●
MFT 10-200-M5	5.5	M5	10	10	200	●
MFT 12-100-M6	6.5	M6	12	12	100	●
MFT 12-150-M6	6.5	M6	12	12	150	●
MFT 12-200-M6	6.5	M6	12	12	200	●
MFT 15-100-M8	8.5	M8	15	15	100	●
MFT 15-150-M8	8.5	M8	15	15	150	●
MFT 15-200-M8	8.5	M8	15	15	200	●
MFT 15-250-M8	8.5	M8	15	15	250	●
MFT 15.6-100-M8	8.5	M8	15.6	15.6	100	●
MFT 15.6-150-M8	8.5	M8	15.6	15.6	150	●
MFT 15.6-200-M8	8.5	M8	15.6	15.6	200	●
MFT 15.6-250-M8	8.5	M8	15.6	15.6	250	●
MFT 15.6-300-M8	8.5	M8	15.6	15.6	300	●
MFT 16-100-M8	8.5	M8	16	16	100	●
MFT 16-120-M8	8.5	M8	16	16	120	●
MFT 16-150-M8	8.5	M8	16	16	150	●
MFT 16-200-M8	8.5	M8	16	16	200	●
MFT 16-250-M8	8.5	M8	16	16	250	●
MFT 16-300-M8	8.5	M8	16	16	300	●
MFT 18-130-M10	10.5	M10	18	18	130	●
MFT 19-100-M10	10.5	M10	19	19	100	●
MFT 19-150-M10	10.5	M10	19	19	150	●
MFT 19-200-M10	10.5	M10	19	19	200	●
MFT 19-250-M10	10.5	M10	19	19	250	●

型号	d	M	D1	D2	L	库存
MFT 19-300-M10	10.5	M10	19	19	300	●
MFT 19-350-M10	10.5	M10	19	19	350	●
MFT20-100-M10	10.5	M10	20	20	100	●
MFT20-150-M10	10.5	M10	20	20	150	●
MFT20-200-M10	10.5	M10	20	20	200	●
MFT20-250-M10	10.5	M10	20	20	250	●
MFT20-300-M10	10.5	M10	20	20	300	●
MFT20-350-M10	10.5	M10	20	20	350	●
MFT24-100-M12	12.5	M12	24	24	100	●
MFT24-150-M12	12.5	M12	24	24	150	●
MFT24-200-M12	12.5	M12	24	24	200	●
MFT24-250-M12	12.5	M12	24	24	250	●
MFT24-300-M12	12.5	M12	24	24	300	●
MFT24-350-M12	12.5	M12	24	24	350	●
MFT24-400-M12	12.5	M12	24	24	400	●
MFT25-100-M12	12.5	M12	25	25	100	●
MFT25-150-M12	12.5	M12	25	25	150	●
MFT25-200-M12	12.5	M12	25	25	200	●
MFT25-250-M12	12.5	M12	25	25	250	●
MFT25-300-M12	12.5	M12	25	25	300	●
MFT25-350-M12	12.5	M12	25	25	350	●
MFT25-400-M12	12.5	M12	25	25	400	●
MFT32-150-M16	17	M16	32	32	150	●
MFT32-200-M16	17	M16	32	32	200	●
MFT32-250-M16	17	M16	32	32	250	●
MFT32-300-M16	17	M16	32	32	300	●
MFT32-350-M16	17	M16	32	32	350	●
MFT32-400-M16	17	M16	32	32	400	●
MFT32-450-M16	17	M16	32	32	450	●
MFT32-500-M16	17	M16	32	32	500	●

模块式锁牙刀头

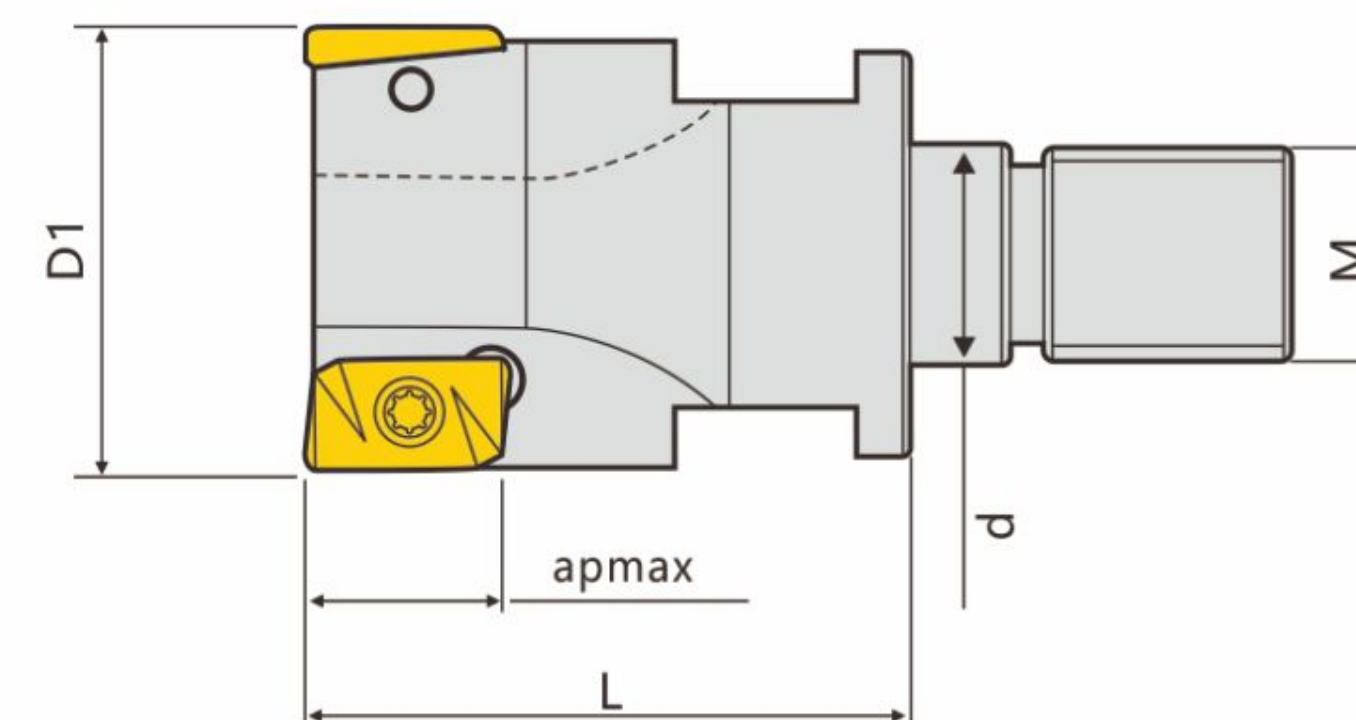

● 库存 Stock

单位: mm

型号	d	D1	L	M	适配刀片	库存	
BAP3-16-2T-M08	8.5	16		M8	APMT 1135	●	
BAP3-17-2T-M08	8.5	17		M8		●	
BAP3-20-2T-M10	10.5	20		M10		●	
BAP3-20-3T-M10	10.5	20		M10		●	
BAP3-21-2T-M10	10.5	21		M10		●	
BAP3-21-3T-M10	10.5	21		M10		●	
BAP3-25-3T-M12	12.5	25		M12		●	
BAP3-25-4T-M12	12.5	25		M12		●	
BAP3-26-3T-M12	12.5	26		M12		●	
BAP3-26-4T-M12	12.5	26		M12		●	
BAP3-33-4T-M16	17	33		M16		●	
BAP3-35-4T-M16	17	35		M16		●	
BAP4-25-2T-M12	12.5	25		M12		APMT 1604	●
BAP4-26-2T-M12	12.5	26		M12			●
BAP4-33-3T-M16	17	33		M16	●		
BAP4-35-3T-M16	17	35		M16	●		
BAP4-40-3T-M16	17	40		M16	●		
ASPVM-16-2T-M08	8.5	16		M8	MPHW0603	●	
ASPVM-17-2T-M08	8.5	17		M8		●	
ASPVM-20-2T-M10	10.5	20		M10		●	
ASPVM-21-2T-M10	10.5	21		M10		●	
ASPVM-21-3T-M10	10.5	21		M10		●	
ASPVM-26-4T-M12	12.5	26		M12		●	
ASPVM-35-4T-M16	17	35		M16		●	
MQT10-17-2T-M08	8.5	17		M8	YPHW100308 ZER-15	●	
MQT10-21-2T-M10	10.5	21		M10		●	
MQT10-21-3T-M10	10.5	21		M10		●	
MQT10-26-4T-M12	12.5	26		M12		●	

型号	d	D1	L	M	适配刀片	库存
WGR08-M04	4.5	8		M4	P3202-D08	●
WGR10-M05	5.5	10		M5	P3202-D10	●
WGR12-M06	6.5	12		M6	P3202-D12	●
WGR16-M08	8.5	16		M8	P3202-D16	●
WGR20-M10	10.5	20		M10	P3202-D20	●
WGR25-M12	12.5	25		M12	P3202-D25	●
WGR30-M16	17	30		M16	P3202-D30	●
WGR32-M16	17	32		M16	P3202-D32	●
PPH08-M04	4.5	8		M4	BNM-080	●
PPH10-M05	5.5	10		M5	BNM-100	●
PPH12-M06	6.5	12		M6	BNM-120	●
PPH16-M08	8.5	16		M8	BNM-160	●
PPH20-M10	10.5	20		M10	BNM-200	●
PPH25-M12	12.5	25		M12	BNM-250	●
PPH30-M16	17	30		M16	BNM-300	●
ABPF08-M04	4.5	8		M4	ZDFG-080	●
ABPF10-M05	5.5	10		M5	ZDFG-100	●
ABPF12-M06	6.5	12		M6	ZDFG-120	●
ABPF16-M08	8.5	16		M8	ZDFG-160	●
ABPF20-M10	10.5	20		M10	ZDFG-200	●
ABPF25-M12	12.5	25		M12	ZDFG-250	●
ABPF30-M16	17	30		M16	ZDFG-300	●
ASM07-08-1T-M04	4.5	8		M4	JDMT0702	●
ASM07-09-1T-M04	4.5	9		M4		●
ASM07-10-2T-M05	5.5	10		M5		●
ASM07-11-2T-M05	5.5	11		M5		●
ASM07-12-2T-M06	6.5	12		M6		●
ASM07-13-2T-M06	6.5	13		M6		●

模块式锁牙刀头

型号	d	D1	L	M	适配刀片	库存	
ASM07-17-3T-M08	8.5	17		M8	JDMT0702	●	
RD05-11-2T-M05	5.5	11		M5	RDEW0501	●	
RD05-13-2T-M06	6.5	13		M6		●	
RD07-16-2T-M08	8.5	16		M8		●	
RD07-17-2T-M08	8.5	17		M8	RDEW0702	●	
RD07-20-2T-M10	10.5	20		M10		●	
RD07-21-2T-M10	10.5	21		M10		●	
RD07-25-4T-M12	12.5	25		M12		●	
RD07-26-4T-M12	12.5	26		M12		●	
RD07-33-4T-M16	17	33		M16		●	
RP08-16-2T-M08	8.5	16		M8		RPMW0802 MO	●
RP08-17-2T-M08	8.5	17		M8			●
RP08-20-2T-M10	10.5	20		M10	●		
RP08-21-2T-M10	10.5	21		M10	RPMT08T2 MOE	●	
RPT08-16-2T-M08	8.5	16		M8		●	
RPT08-17-2T-M08	8.5	17		M8		●	
RPT08-20-2T-M10	10.5	20		M10		●	
RPT08-21-2T-M10	10.5	21		M10	RDMT0802 MO	●	
RD08-16-2T-M08	8.5	16		M8		●	
RD08-17-2T-M08	8.5	17		M8		●	
RD08-20-2T-M10	10.5	20		M10		●	
RD08-21-2T-M10	10.5	21		M10		●	
RP10-20-2T-M10	10.5	20		M10	RPMW1003 MO	●	
RP10-21-2T-M10	10.5	21		M10		●	
RP10-25-2T-M12	12.5	25		M12		●	
RP10-26-2T-M12	12.5	26		M12		●	
RP10-35-3T-M16	17	35		M16		●	
RD10-25-2T-M12	12.5	25		M12	RDMW10T3 MOT	●	
RD10-26-2T-M12	12.5	26		M12		●	
RD10-35-3T-M16	17	35		M16		●	
RPT10-25-2T-M12	12.5	25		M12	RPMT10T3 MOE	●	
RPT10-26-2T-M12	12.5	26		M12		●	
RPT10-35-3T-M16	17	35		M16		●	
RD12-26-2T-M16	17	26		M16	RDEW1204 MOT	●	
RD12-32-2T-M12	12.5	32		M12		●	
RD12-33-2T-M16	17	33		M16		●	
RD12-35-3T-M16	17	35		M16		●	
RD12-40-3T-M16	17	40		M16		●	
R200-25-2T-M12	12.5	25		M12	RCKT10T3/1204	●	
R200-26-2T-M12	12.5	26		M12		●	

型号	d	D1	L	M	适配刀片	库存
R200-5R32-2T-M12	12.5	32		M12	RCKT10T3/1204	●
R200-5R33-2T-M16	17	33		M16		●
R200-32-2T-M12	12.5	32		M12		●
R200-33-2T-M16	17	33		M16		●
R390-16-2T-M08	8.5	16		M8	R390-11T308	●
R390-17-2T-M08	8.5	17		M8		●
R390-20-2T-M10	10.5	20		M10		●
R390-21-2T-M10	10.5	21		M10		●
R390-25-2T-M12	12.5	25		M12		●
R390-25-3T-M12	12.5	25		M12		●
R390-25-4T-M12	12.5	25		M12		●
R390-26-2T-M12	12.5	26		M12		●
R390-26-3T-M12	12.5	26		M12		●
R390-26-4T-M12	12.5	26		M12		●
R390-32-4T-M16	17	32		M16		●
R390-33-4T-M16	17	33		M16		●
R390-35-4T-M16	17	35		M16		●
EXN3-16-2T-M08	8.5	16		M8		LNMU0303ZER
EXN3-17-2T-M08	8.5	17		M8	●	
EXN3-20-3T-M10	10.5	20		M10	●	
EXN3-21-2T-M10	10.5	21		M10	●	
EXN3-21-3T-M10	10.5	21		M10	●	
EXN3-25-4T-M12	12.5	25		M12	●	
EXN3-26-4T-M12	12.5	26		M12	●	
EXN3-35-5T-M16	17	35		M16	●	



希娅特科技有限公司

地址: 浙江省台州市黄岩区高桥街道上山村79号

手机: 187 5830 5888

E-mail: manager@syattools.com



2024-2026